

**Lecture Notes on
POWER ELECTRONICS & PLC**



**5TH SEMESTER DIPLOMA (EE)
SUBJECT CODE: TH-5**



**PREPARED BY
SARADA PRASANA
BEHERA**

**GOVERNMENT POLYTECHNIC, KENDRAPARA
Department of Electrical Engineering
Derabishi, Odisha 754289
www.gpkendrapara.org**

MODULE-I

POWER ELECTRONICS

The control of electric motor drives requires control of electric power. Power electronics have eased the concept of power control. Power electronics signifies the word power electronics and control or we can say the electronic that deal with power equipment for power control.

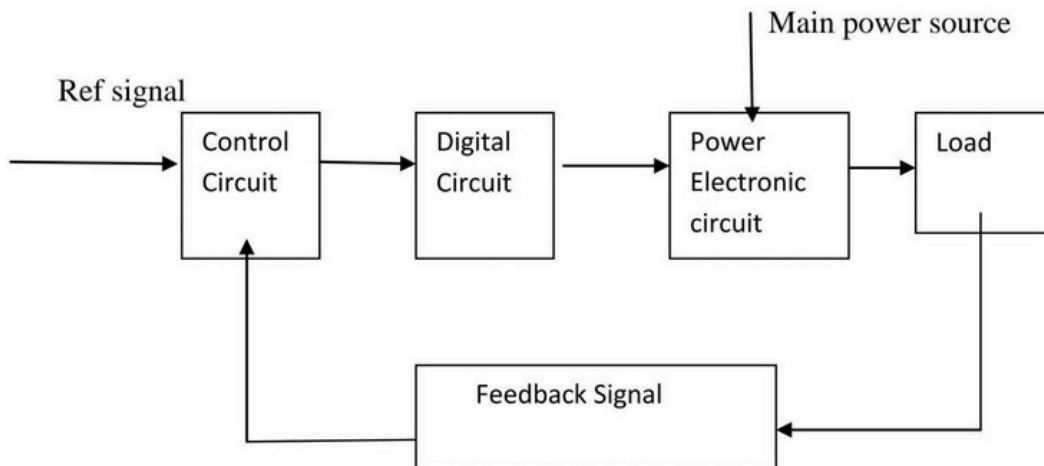

Power electronics based on the switching of power semiconductor devices. With the development of power semiconductor technology, the power handling capabilities and switching speed of power devices have been improved tremendously.

Power Semiconductor Devices

The first SCR was developed in late 1957. Power semiconductor devices are broadly categorized into 3 types:

1. Power diodes (600V,4500A)
2. Transistors
3. Thyristors (10KV,300A,30MW)

Thyristor is a four layer three junction pnpn semiconductor switching device. It has 3 terminals these are anode, cathode and gate. SCRs are solid state device, so they are compact, possess high reliability and have low loss.

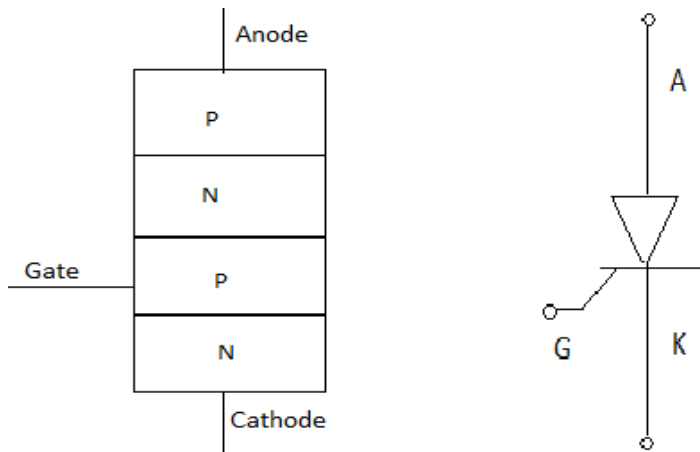

SCR is made up of silicon, it act as a rectifier; it has very low resistance in the forward direction and high resistance in the reverse direction. It is a unidirectional device.

Static V-I characteristics of a Thyristor

The circuit diagram for obtaining static V-I characteristics is as shown

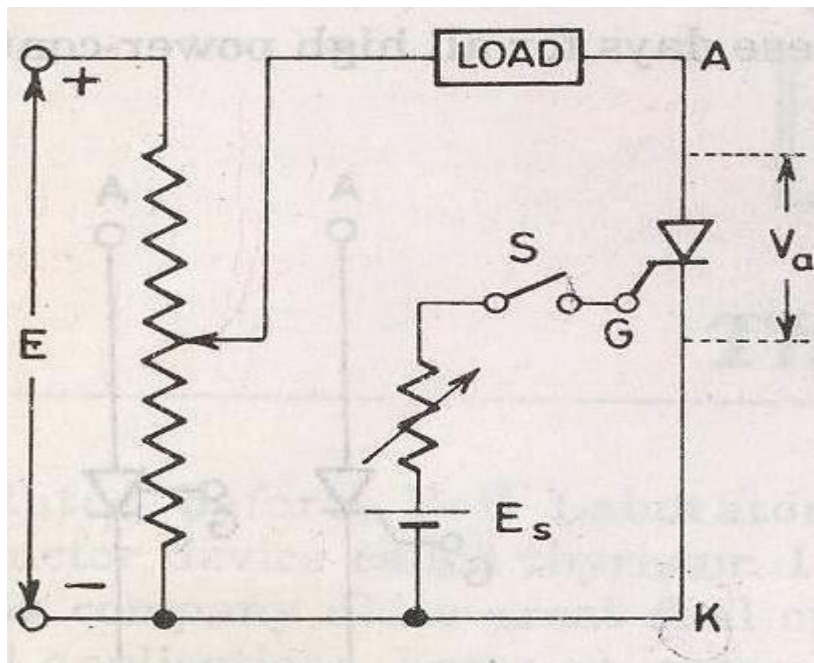

Anode and cathode are connected to main source voltage through the load. The gate and cathode are fed from source E_s .

A typical SCR V-I characteristic is as shown below:

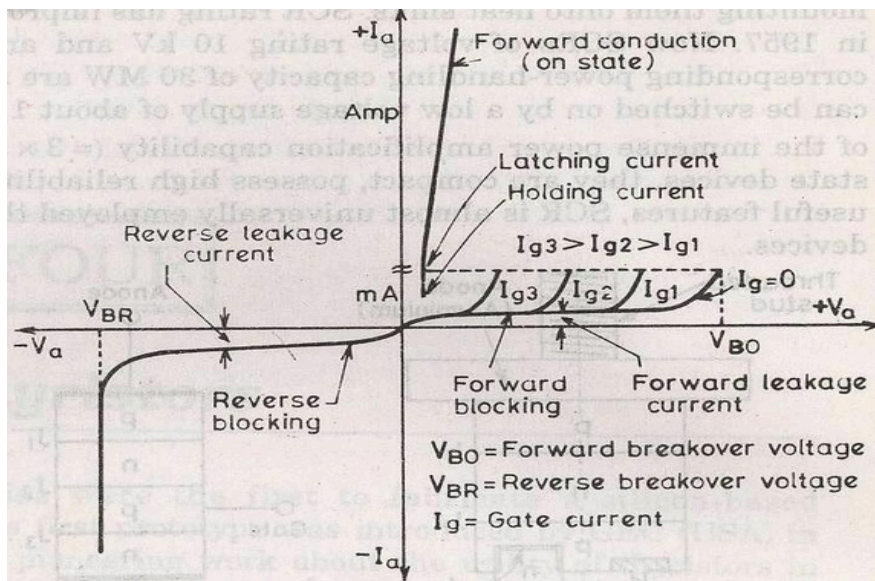

V_{BO} =Forward breakover voltage

V_{BR} =Reverse breakover voltage

I_g =Gate current

V_a =Anode voltage across the thyristor terminal A,K.

I_a =Anode current

It can be inferred from the static V-I characteristic of SCR. SCR have 3 modes of operation:

- 1.Reverse blocking mode
- 2.Forward blocking mode (off state)
- 3.Forward conduction mode (on state)

1. Reverse Blocking Mode

When cathode of the thyristor is made positive with respect to anode with switch open thyristor is reverse biased. Junctions J_1 and J_2 are reverse biased where junction J_2 is forward biased. The device behaves as if two diodes are connected in series with reverse voltage applied across them.

- A small leakage current of the order of few mA only flows. As the thyristor is reverse biased and in blocking mode. It is called as acting in reverse blocking mode of operation.
- Now if the reverse voltage is increased, at a critical breakdown level called reverse breakdown voltage V_{BR} ,an avalanche occurs at J_1 and J_3 and the reverse

current increases rapidly. As a large current associated with V_{BR} and hence more losses to the SCR.

This results in Thyristor damage as junction temperature may exceed its maximum temperature rise.

2. Forward Blocking Mode

When anode is positive with respect to cathode, with gate circuit open, thyristor is said to be forward biased.

Thus junction J_1 and J_3 are forward biased and J_2 is reverse biased. As the forward voltage is increases junction J_2 will have an avalanche breakdown at a voltage called forward breakover voltage V_{BO} . When forward voltage is less then V_{BO} thyristor offers high impedance. Thus a thyristor acts as an open switch in forward blocking mode.

3. Forward Conduction Mode

Here thyristor conducts current from anode to cathode with a very small voltage drop across it. So a thyristor can be brought from forward blocking mode to forward conducting mode:

1. By exceeding the forward breakover voltage.
2. By applying a gate pulse between gate and cathode.

During forward conduction mode of operation thyristor is in on state and behave like a close switch. Voltage drop is of the order of 1 to 2mV. This small voltage drop is due to ohmic drop across the four layers of the device.

Different turn ON methods for SCR

- 1 Forward voltage triggering
- . Gate triggering
- 2 $\frac{dv}{dt}$ triggering
- . Light triggering
- 3
5. Temperature triggering
- .
- 4

1. Forward voltage triggering

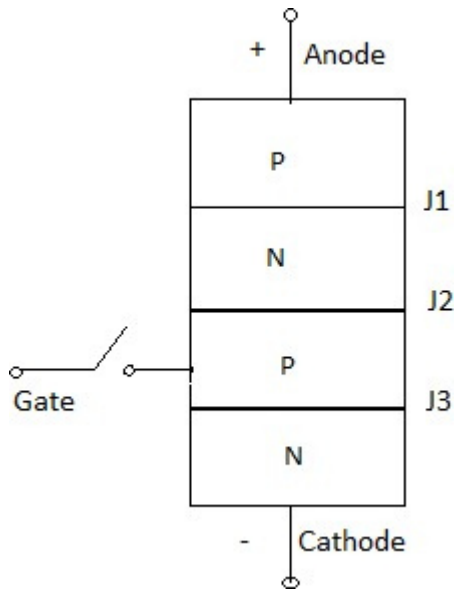

A forward voltage is applied between anode and cathode with gate circuit open.

- Junction $J1$ and $J3$ is forward biased.
- Junction $J2$ is reverse biased.
- As the anode to cathode voltage is increased breakdown of the reverse biased junction $J2$ occurs. This is known as avalanche breakdown and the voltage at which this phenomena occurs is called forward breakover voltage.
- The conduction of current continues even if the anode cathode voltage reduces below V_{BO} till I_a will not go below I_h . Where I_h is the holding current for the thyristor.

2. Gate triggering

This is the simplest, reliable and efficient method of firing the forward biased SCRs. First SCR is forward biased. Then a positive gate voltage is applied between gate and cathode. In practice the transition from OFF state to ON state by exceeding V_{BO} is never employed as it may destroy the device. The magnitude of V_{BO} , so forward breakover voltage is taken as final voltage rating of the device during the design of SCR application.

First step is to choose a thyristor with forward breakover voltage (say 800V) higher than the normal working voltage. The benefit is that the thyristor will be in blocking state with normal working voltage applied across the anode and cathode with gate open. When we require the turning ON of a SCR a positive gate voltage between gate and cathode is applied. The point to be noted that cathode n- layer is heavily doped as compared to gate p-layer. So when gate supply is given between gate and cathode gate p-layer is flooded with electron from cathode n-layer. Now the thyristor is forward biased, so some of these electron reach junction $J2$. As a result width of $J2$ breaks down or conduction at $J2$ occur at a voltage less than V_{BO} . As I_g increases V_{BO} reduces which decreases then turn ON time. Another important point is duration for which the gate current is applied should be more then turn ON time. This means

that if the gate current is reduced to zero before the anode current reaches a minimum value known as holding current, SCR can't turn ON.

In this process power loss is less and also low applied voltage is required for triggering.

3. dv/dt triggering

This is a turning ON method but it may lead to destruction of SCR and so it must be avoided.

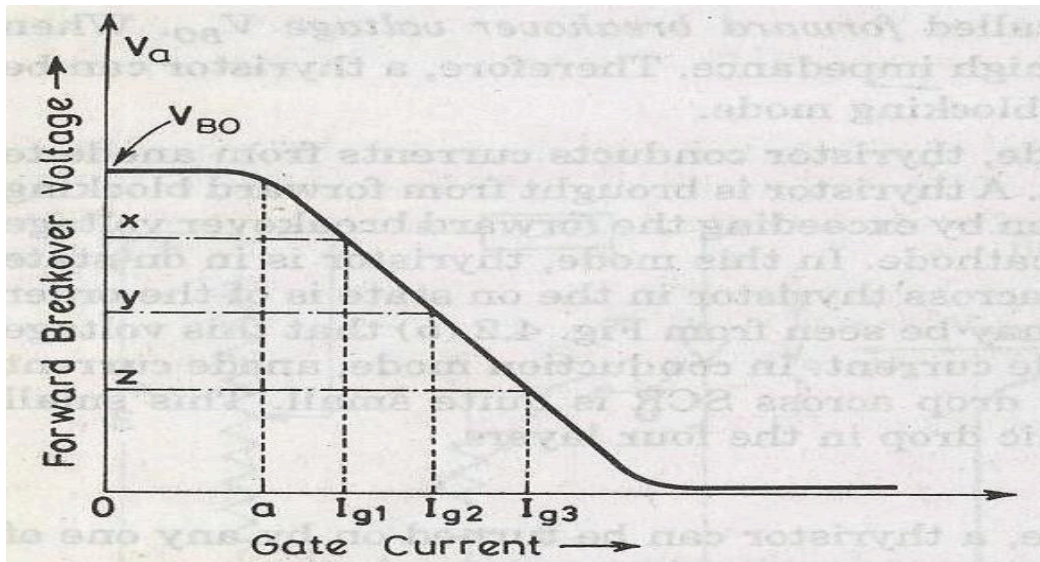

When SCR is forward biased, junction $J1$ and $J3$ are forward biased and junction $J2$ is reverse biased so it behaves as if an insulator is placed between two conducting plates. Here $J1$ and $J3$ act as a conducting plate and $J2$ acts as an insulator. $J2$ is known as junction capacitor.

So if we increase the rate of change of forward voltage instead of increasing the magnitude of

voltage. Junction $J2$ breaks and starts conducting. A high value of changing current may

damage the SCR. So SCR may be protected from high dv/dt .

$$q = cv$$

$$I_a = c \frac{dv}{dt}$$

$$I_{a\alpha} \frac{dv}{dt}$$

4. Temperature triggering During forward biased, $J2$ is reverse biased so a leakage

forward current always associated

with SCR. Now as we know the leakage current is temperature dependant, so if we increase

the temperature the leakage current will also increase and heat dissipation of junction $J2$ occurs. When this heat reaches a sufficient value $J2$ will break and conduction starts.

Disadvantages

This type of triggering causes local hot spot and may cause thermal run away of the device.

This triggering cannot be controlled easily.

It is very costly as protection is costly.

5. Light triggering

First a new recess niche is made in the inner p-layer. When this recess is irradiated, then free charge carriers (electron and hole) are generated. Now if the intensity is increased above a certain value then it leads to turn ON of SCR. Such SCR are known as Light activated SCR (LASCR).

Some definitions:

Latching current

The latching current may be defined as the minimum value of anode current which at must attain during turn ON process to maintain conduction even if gate signal is removed.

Holding current

It is the minimum value of anode current below which if it falls, the SCR will turn OFF.

Switching characteristics of thyristors

The time variation of voltage across the thyristor and current through it during turn on and turn off process gives the dynamic or switching characteristic of SCR.

Switching characteristic during turn on

Turn on time

It is the time during which it changes from forward blocking state to ON state. Total turn on time is divided into 3 intervals:

1. Delay time

2. Rise time

3. Spread time **Delay time** If I_g and I_a represent the final value of gate current and

anode current. Then the delay time

can be explained as time during which the gate current attains $0.9 I_g$ to the instant anode

current reaches $0.1 I_g$ or the anode current rises from forward leakage current to

$0.1 I_a$.

1 Gate current $0.9 I_g$ to $0.1 I_a$.

2 Anode voltage falls from V_a to $0.9 V_a$.
Anode current rises from forward leakage current to $0.1 I_a$.

.

.

3

.

Rise time (t_r)

Time during which

¹ Anode current rises from $0.1 I_a$ to $0.9 I_a$. Forward blocking voltage falls from $0.9 V_a$ to $0.1 V_a$. V_a is the initial forward blocking voltage.

Spread time (t_p)

¹ Time taken by the anode current to rise from $0.9 I_a$ to I_a . Time for the forward voltage to fall from $0.1 V_o$ to on state voltage drop of 1 to 1.5V.

² During turn on, SCR is considered to be a charge controlled device. A certain amount of charge is injected in the gate region to begin conduction. So higher the magnitude of gate current it requires less time to inject the charges. Thus turn on time is

How the distribution of charge occurs?

by using large magnitude of gate current.
As the gate current begins to flow from gate to cathode with the application of gate signal. Gate current has a non uniform distribution of current density over the cathode surface. Distribution of current density is much higher near the gate. The density decrease as the distance from the gate increases. So anode current flows in a narrow region near gate where gate current densities are highest. From the beginning of rise time the anode current starts spreading itself. The anode current spread at a rate of 0.1mm/sec. The spreading anode current requires some time if the rise time is not sufficient then the anode current cannot spread over the entire region of cathode. Now a large anode current is applied and also a large anode current flowing through the SCR. As a result turn on losses is high. As these losses occur over a small conducting region so local hot spots may form and it may damage the device.

Switching Characteristics During Turn Off

Thyristor turn off means it changed from ON to OFF state. Once thyristor is ON there is no role of gate. As we know thyristor can be made turn OFF by reducing the anode current below the latching current. Here we assume the latching current to be zero ampere. If a forward voltage is applied across the SCR at the moment it reaches zero then SCR will not be able to block this forward voltage. Because the charges trapped in the 4-layer are still favourable for conduction and it may turn on the device. So to avoid such a case, SCR is reverse biased for some time even if the anode current has reached to zero.

So now the turn off time can be different as the instant anode current becomes zero to the instant when SCR regains its forward blocking capability.

$$t_q = t_{rr} + t_{qr}$$

Where,

t_q is the turn off time, t_{rr} is the reverse recovery time, t_{gr} is the gate recovery time

At t_1 anode current is zero. Now anode current builds up in reverse direction with same

reverse $\frac{di}{dt}$ slope. This is due to the presence of charge carriers in the four layers. The

recovery current removes the excess carriers from J_1 and J_3 between the instants t_1 and t_3 .

At instant t_3 the end junction J_1 and J_3 is recovered. But J_2 still has trapped charges which

decay due to recombination only so the reverse voltage has to be maintained for some

more time. The time taken for the recombination of charges between t_3 and t_4 is

1. Junction temperature

2. Magnitude of forward current I_a during commutation.

gate recovery time t_{gr} . Junction J_2 recovered and now a forward voltage can be applied

Turn off time decreases with the increase of magnitude of reverse applied voltage across SCR. The turn off time is affected by:

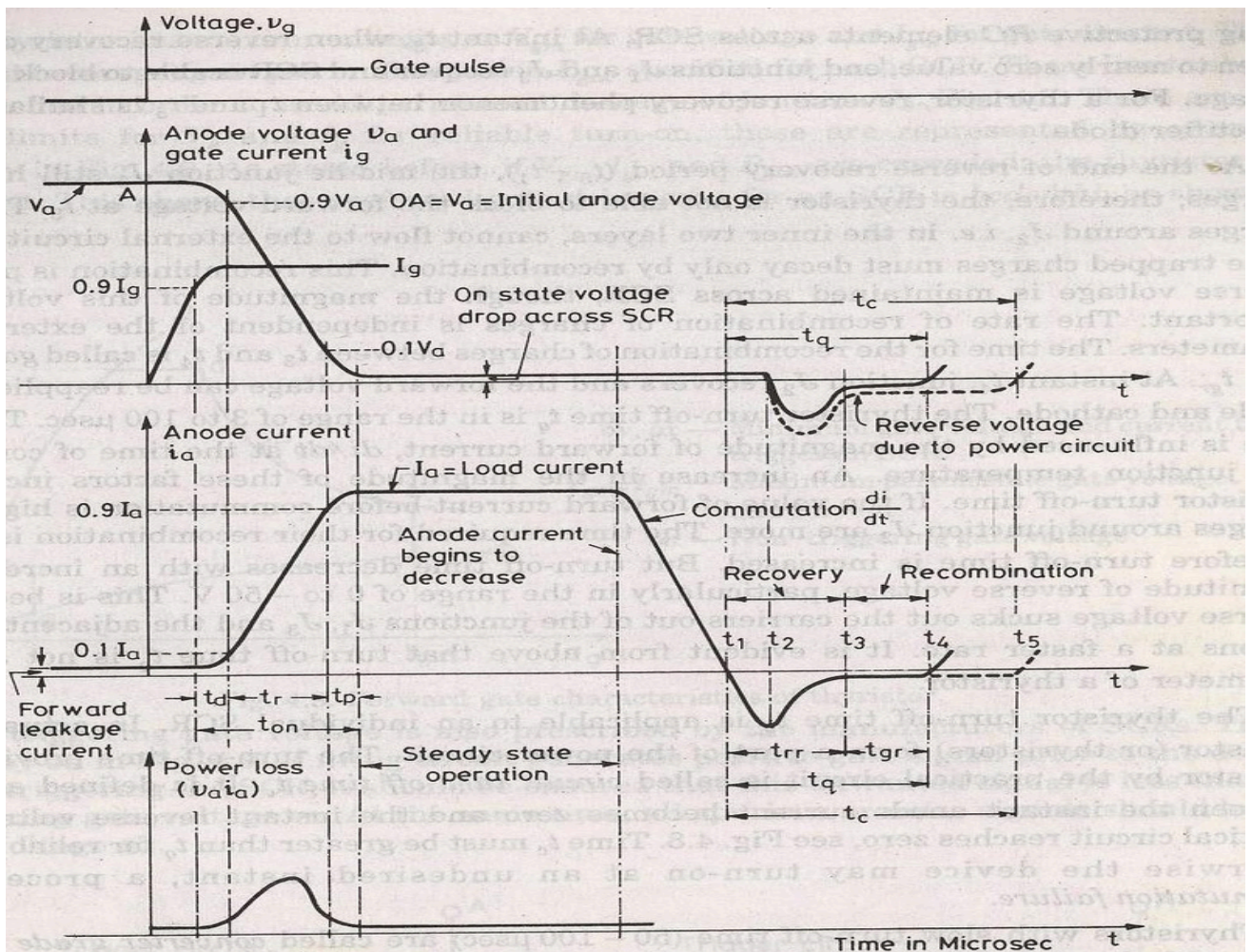

GTO(Gate turn off thyristor)

A gate turn off thyristor is a pnpn device. In which it can be turned ON like an ordinary SCR by a positive gate current. However it can be easily turned off by a negative gate pulse of appropriate magnitude.

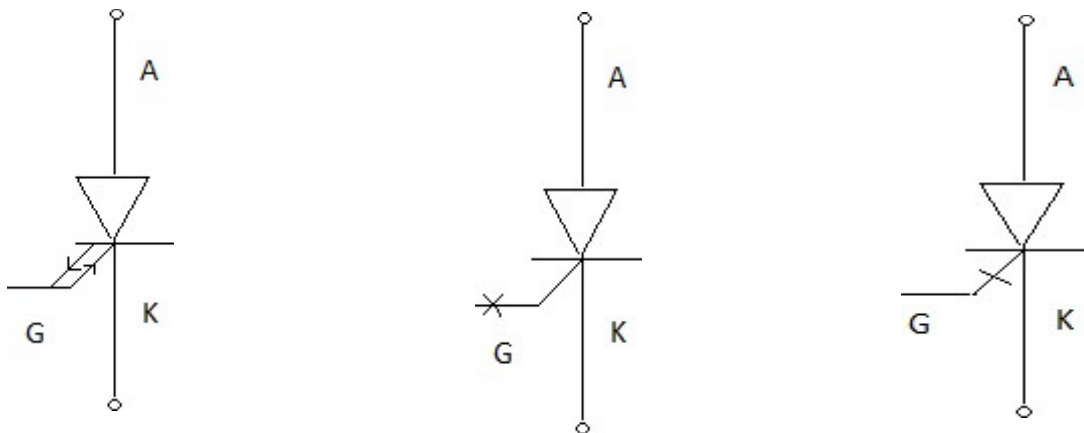

Conventional SCR are turned on by a positive gate signal but once the SCR is turned on gate loses control over it. So to turn it off we require external commutation circuit. These commutation circuits are bulky and costly. So due to these drawbacks GTO comes into existence.

The salient features of GTO are:

- 1 GTO turned on like conventional SCR and is turned off by a negative gate signal of sufficient magnitude.
- It is a non latching device.
2. GTO reduces acoustic and electromagnetic noise. It has high switching frequency and efficiency.

A gate turn off thyristor can turn on like an ordinary thyristor but it is turn off by negative gate pulse of appropriate magnitude.

Disadvantage

The negative gate current required to turn off a GTO is quite large that is 20% to 30 % of anode current

Advantage

It is compact and cost less

Switching performance

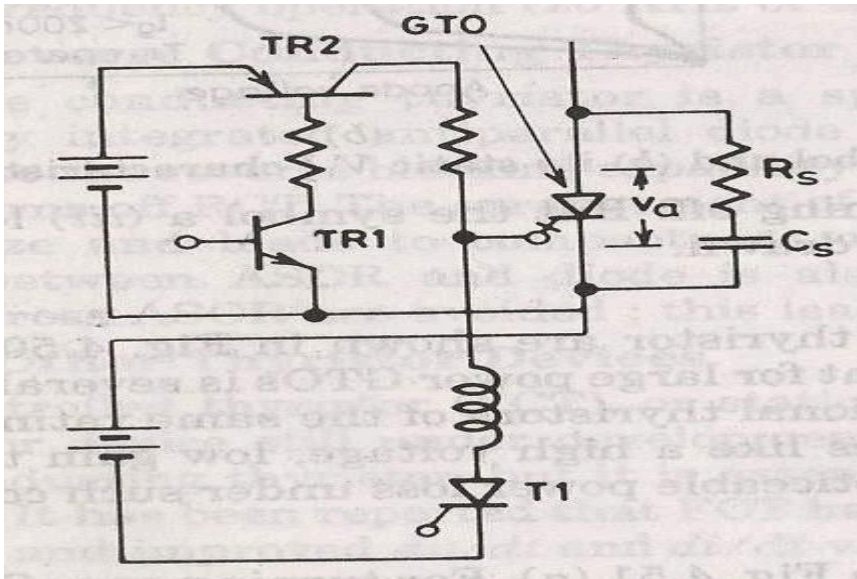

- 1 For turning ON a GTO first TR1 is turned on.
 - . This in turn switches on TR2 so that a positive gate current pulse is applied to turn on
- 2 the GTO.
 - . Thyristor $T1$ is used to apply a high peak negative gate current pulse.

3 Gate turn-on characteristics

1. The gate turn on characteristics is similar to a thyristor. Total turn on time consists of delay time, rise time, spread time.
2. The turn on time can be reduced by increasing its forward gate current.

GATE TURN OFF

Turn off time is different for SCR. Turn off characteristics is divided into 3 pd

1. Storage time
2. Fall time
3. Tail time

$$T_q = t_s + t_f + t_t$$

At normal operating condition gto carries a steady state current. The turn off process starts as soon as negative current is applied after

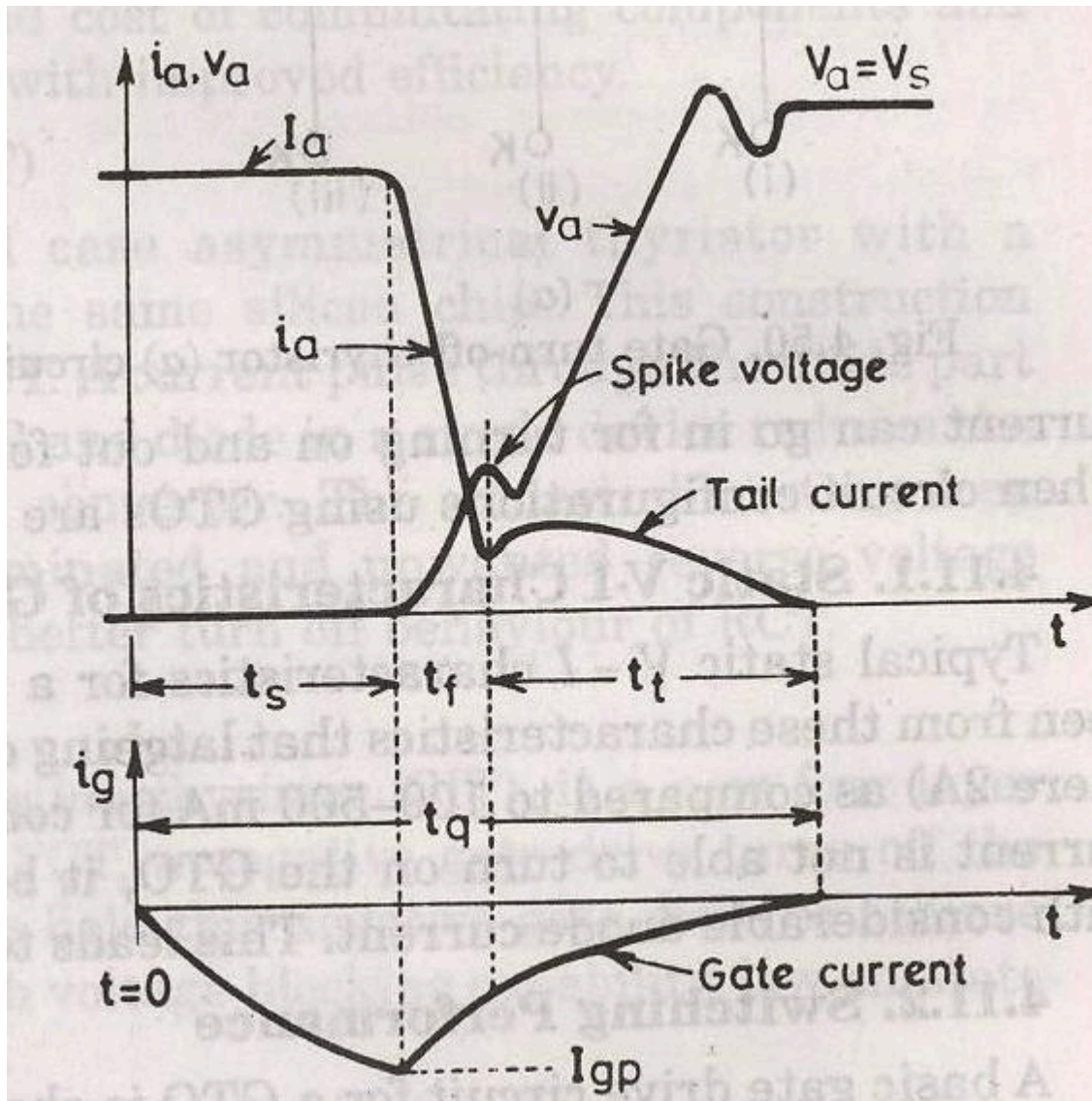

t=0.

STORAGE TIME

During the storage pd the anode voltage and current remains constant. The gate current rises depending upon the gate circuit impedance and gate applied voltage. The beginning of pd is as soon as negative gate current is applied. The end of storage pd is marked by fall in anode current and rise in voltage, what we have to do is remove the excess carriers. The excess carriers are removed by negative carriers.

FALL TIME

After t_s , anode current begins to fall rapidly and anode voltage starts rising. After falling to a certain value, then anode current changes its rate to fall. This time is called fall time.

SPIKE IN VOLTAGE

During the time of storage and fall time there is a change in voltage due to abrupt current change. TAIL TIME

During this time, the anode current and voltage continues towards the turn off values. The transient overshoot is due to the snubber parameter and voltage stabilizes to steady state value.

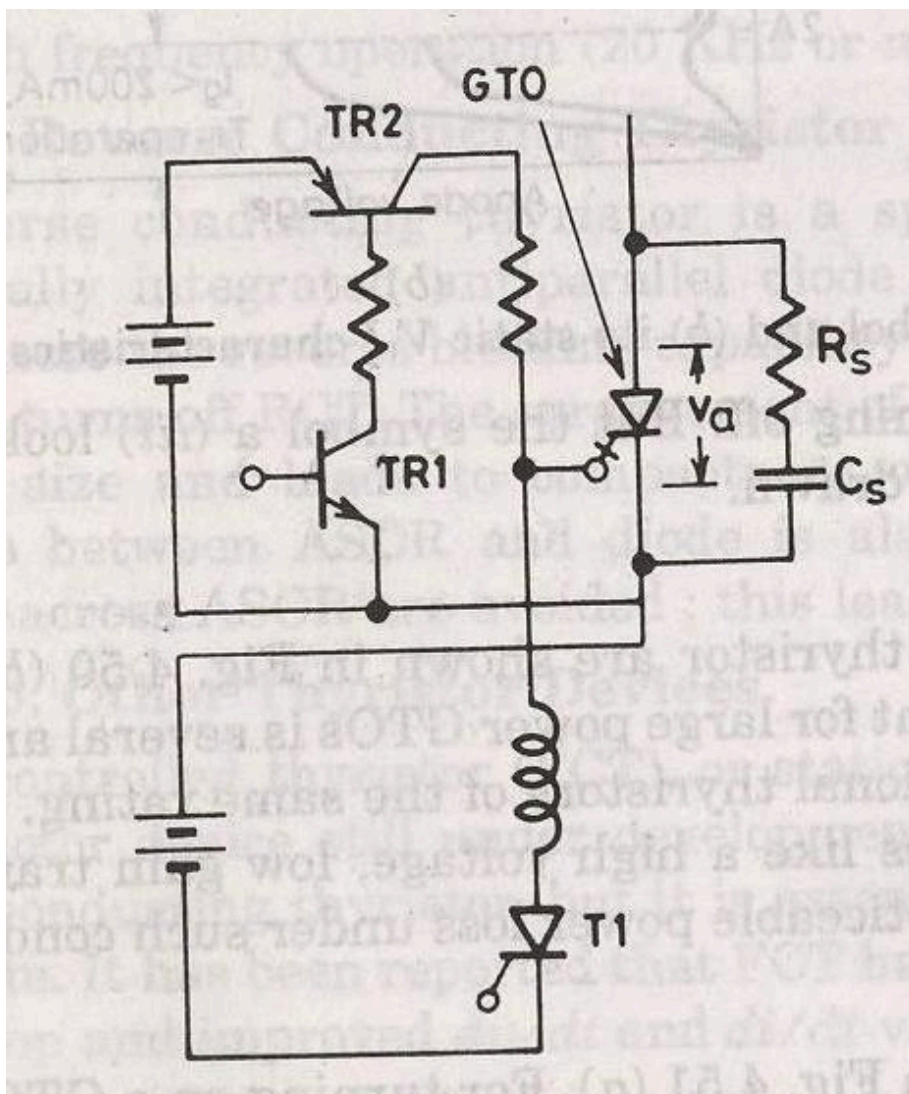

THE TRIAC

As SCR is a unidirectional device, the conduction is from anode to cathode and not from cathode to anode. It conducts in both direction. It is a bidirectional SCR with three terminal. TRIAC=TRIODE+AC

Here it is considered to be two SCRS connected in anti parallel. As it conducts in both direction so it is named as MT1, MT2 and gate G.

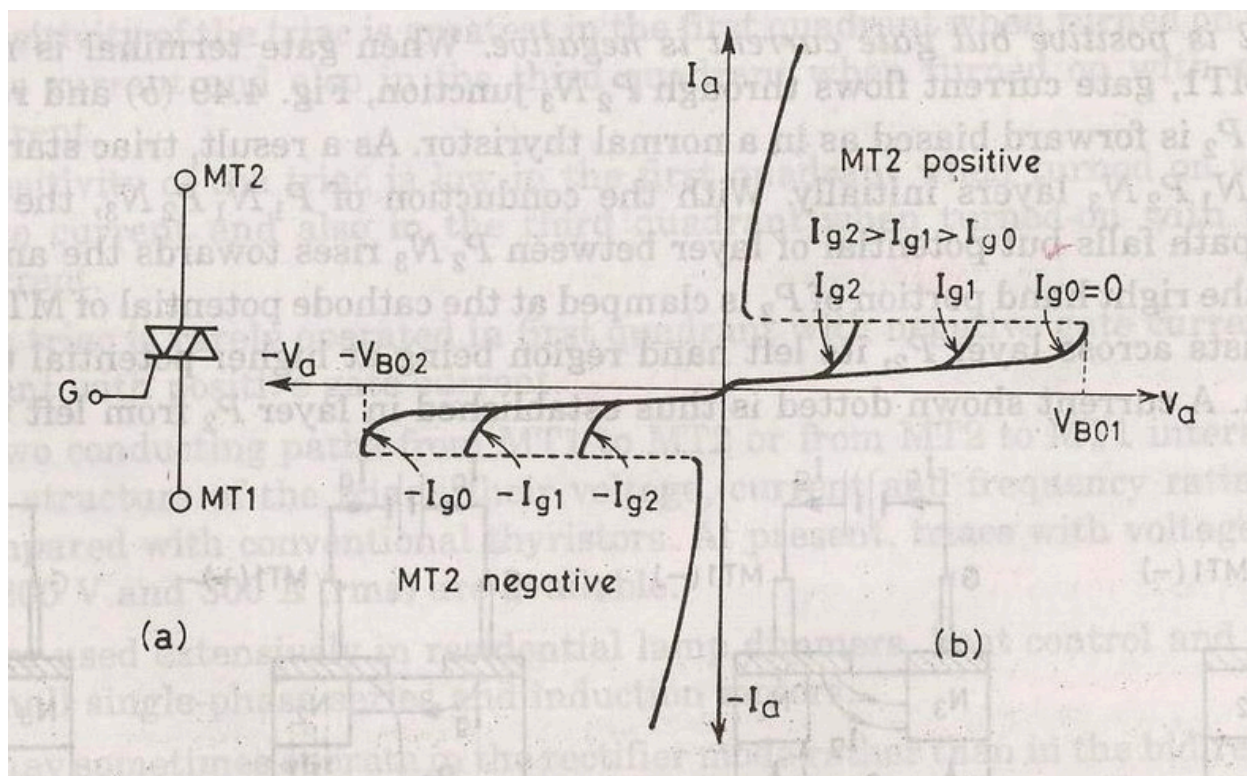

SALIENT FEATURES

1. Bi directional triode thyristor
2. TRIAC means triode that works on ac
3. It conduct in both direction
4. It is a controlled device

5. Its operation is similar to two diodes connected in anti parallel with common gate connection.

6. It has 3 terminals MT1, MT2 and gate

G Its use is control of power in ac

POWER BJT

Power BJT means a large voltage blocking in the OFF state and high current carrying capability in the ON state. In most power application, base is the input terminal. Emitter is the common terminal.

Collector is the output terminal.

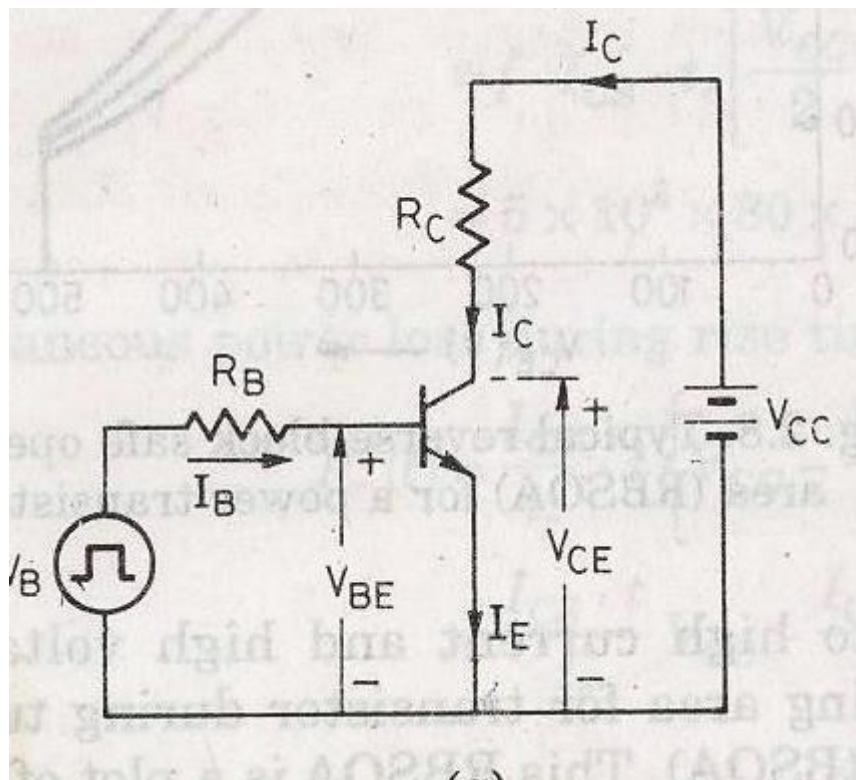

SIGNAL LEVEL OF BJT

n^+ doped emitter layer, doping of base is more than collector. Depletion layer exists more towards the collector than emitter

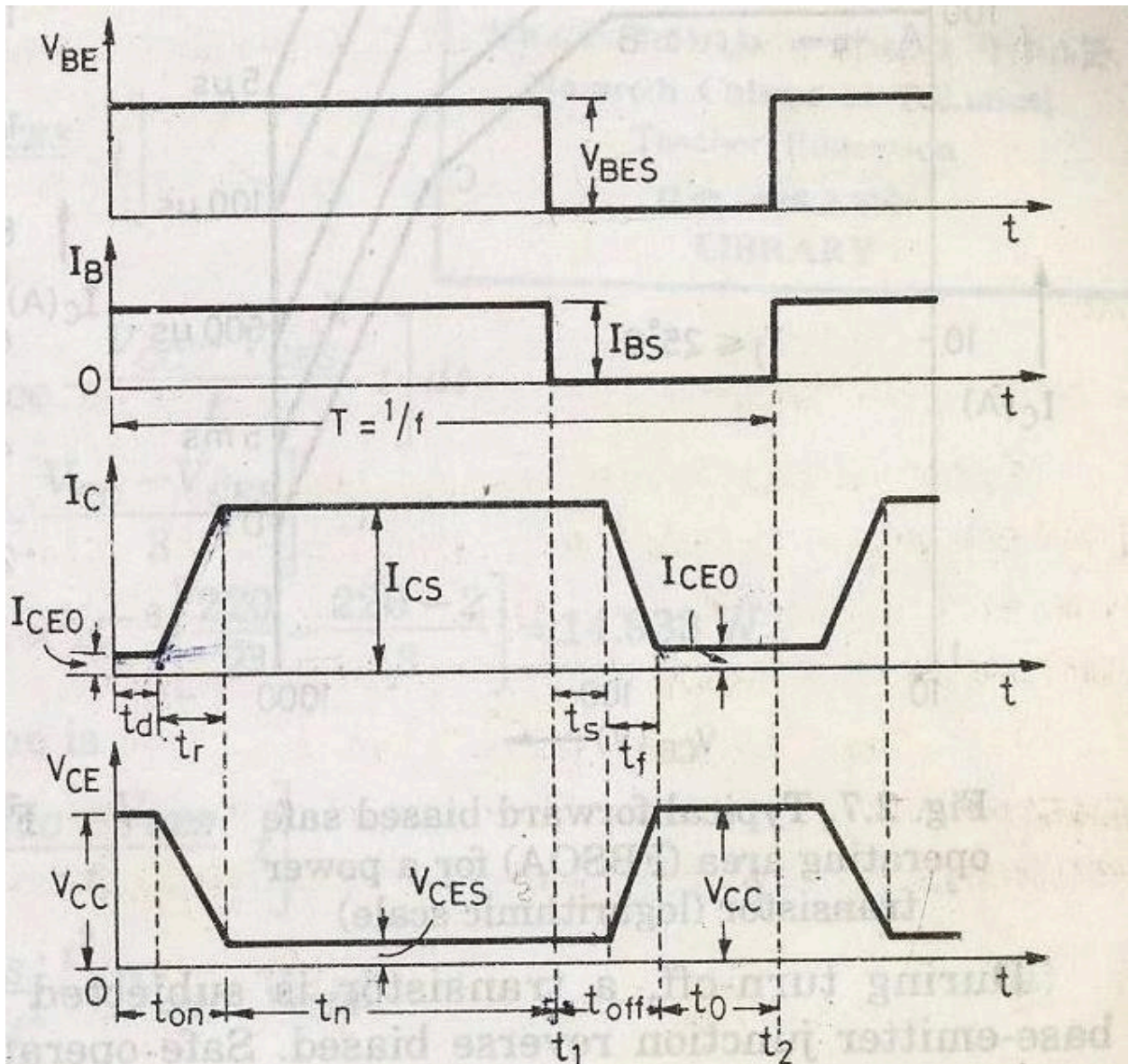

POWER BJT CONSTRUCTION

The maximum collector emitter voltage that can be sustained across the junction, when it is carrying substantial collector current.

V_{CE0} = maximum collector and emitter voltage that can be sustained by the device.

V_{CBO} = collector base breakdown voltage with emitter open

PRIMARY BREAKDOWN

It is due to avalanche breakdown of the C-B junction and its associated large flow of current. The thickness of the depletion region determines the breakdown voltage of the transistor. The base thickness is made as small as possible, in order to have good amplification capability. If the thickness is too small, the breakdown voltage is compromised. So a compromise has to be made between the two.

THE DOPING LEVELS-

1. The doping of the emitter layer is quite large.

2. The base doping is

moderate. 3. n- region is lightly

doped.

4. n+ region doping level is similar to emitter.

1. THICKNESS OF DRIFT REGION-

It determines the breakdown length of the transistor.

2. THE BASE THICKNESS –

Small base thickness- good amplification capability

Too small base thickness- the breakdown voltage of the transistor has to be compromised.

For a relatively thick base, the current gain will be relatively small. So it is increase the gain. Monolithic designs for darlington connected BJT pair have been developed.

SECONDARY BREAKDOWN

Secondary breakdown is due to large power dissipation at localized site within the semiconductor.

PHYSICS OF BJT OPERATION-

The transistor is assumed to operate in active region. There is no doped collector drift region. It has importance only in switching operation, in active region of operation.

junction is forward biased and C-B junction is reverse biased. Electrons are injected into base from the emitter. Holes are injected from base into the emitter.

QUASI SATURATION-

Initially we assume that, the transistor is in active region. Base current is allowed to increase then let's see what happens. First collector rises in response to base current. So there is an increase in voltage drop across the collector load. So C-E voltage drops.

Because of increase in collector current, there is an increase in voltage in drift region. This gets

smaller, at some point the junction becomes forward biased. So now injection of holes from base into collector drift region occurs. Charge neutrality requires the electrons to be injected in the drift region of the holes. From where these electrons came. Since a large number of electrons is supplied to the C-B junction via injection from emitter and subsequent diffusion across the base. As excess carrier build up in the drift region begins to occur quasi saturation region is entered. As the injected carriers increase in the drift region is

gradually shorted out and the voltage across the drift region drops. In quasi saturation the drift region is not completely shorted out by high level injection. Hard saturation obtained when excess carrier density reaches the n^+ side.

During quasi saturation, the rate of the collector fall. Hard saturation occurs when excess carriers have completely swept across the drift region .

THYRISTOR PROTECTION

OVER VOLTAGE PROTECTION

Over voltage occurring during the switching operation causes the failure of SCR.

INTERNAL OVERVOLTAGE

It is due to the operating condition of SCR.

During the commutation of SCR, when the anode current decays to zero anode current reverses due to stored charges. First the reverse current rises to peak value, then reverse current reduces abruptly with large di/dt . During series inductance of SCR large transient large voltage $i.e. L \frac{di}{dt}$ is generated.

EXTERNAL OVER VOLTAGE

This is due to external supply and load condition. This is because of

1. The interruption of current flow in an inductive circuit.
2. Lightning strokes on the lines feeding the thyristor systems.

Suppose a SCR converter is fed from a transformer, voltage transient occur when transformer primary will energise or de-energised.

This overvoltages cause random turn ON of a SCR.

The effect of overvoltage is minimized using

1. RC circuits
2. Non linear resistor called voltage clamping device.

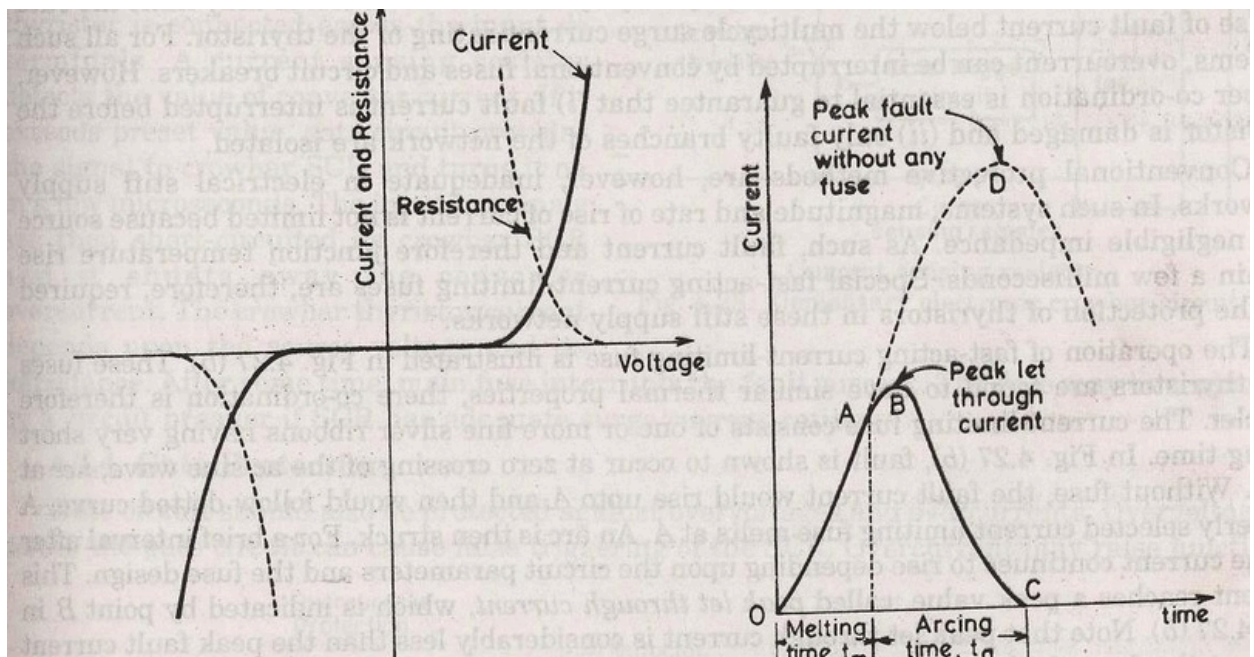

Voltage clamping device is a non linear resistor. It is connected between cathode and anode of SCR. The resistance of voltage clamping device decreases with increasing voltages. During normal working condition Voltage clamping (V.C) device has high resistance, drawing only leakage current. When voltage surge appears voltage clamping device offers a low resistance and it create a virtual short circuit across the SCR. Hence voltage across SCR is clamped to a safe value.

When state condition voltage voltage on device 1. Selection of thyristor is based on
2. Metal Oxide varistors 3. Avalanche diode suppressors

OVER CURRENT PROTECTION

Long duration operation of SCR, during over current causes the

1. junction temp. of SCR to rise above the rated value, causing permanent damage to device.

SCR is protected from overcurrent by using

1. Circuit breakers
2. Fast acting fuses

Proper co-ordination is essential because

1. fault current has to be interrupted before SCR gets damaged.
2. only faulty branches of the network has to be replaced.

In stiff supply network, source has negligible impedance. So in such system the magnitude and rate of rise of current is not limited. Fault current hence

junction temp rises in a few milliseconds.

POINTS TO BE NOTED-

1. Proper coordination between fast acting fuse and thyristor is essential.
2. The fuse is always rated to carry marginal overload current over definite period.
3. The peak let through current through SCR must be less than sub cycle rating of the SCR.
4. The voltage across the fuse during arcing time is called arcing or recovery voltage and is equal to sum of the source voltage and emf induced in the circuit inductance during arcing time.
5. On abrupt interruption of fuse current, induce emf would be high, which results in high arcing voltage.

Circuit Breaker (C.B)

C.B. has long tripping time. So it is used for protecting the device against continuous overload current or against the surge current for long duration. In order that fuse protects the thyristor reliably the I^2t rating of fuse current must be less than that of SCR.

ELECTRONIC CROWBAR PROTECTION

For overcurrent protection of power converter using SCR, electronic crowbar are used. It provide rapid isolation of power converter before any damage occurs.

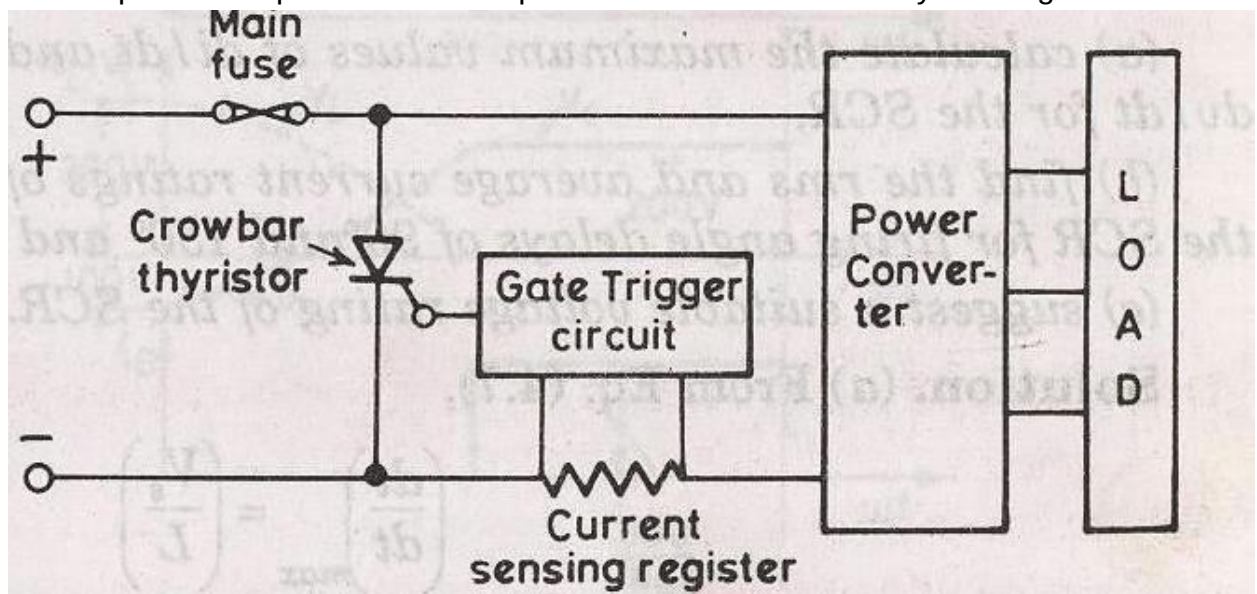

HEAT PROTECTION-

To protect the SCR

1. From the local spots
2. Temp rise

SCRs are mounted over heat sinks.

GATE PROTECTION-

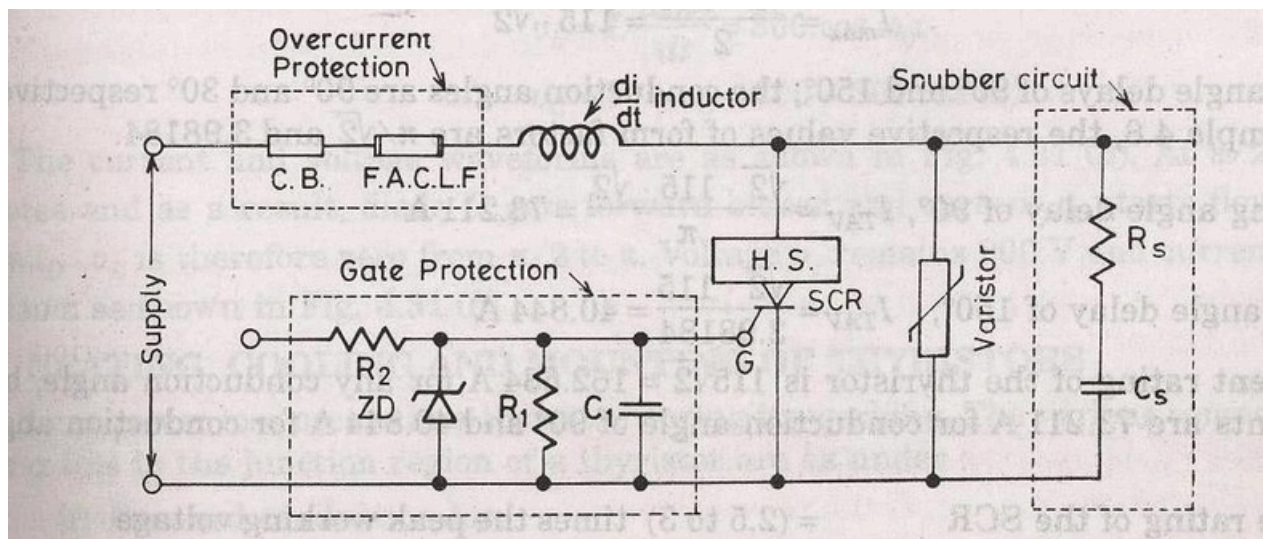

Gate circuit should also be protected from

1. Overvoltages
2. Overcurrents

Overvoltage across the gate circuit causes the false triggering of SCR

Overcurrent raise the junction temperature. Overvoltage protection is by ~~zener~~ diode gate across the circuit.

INSULATED GATE BIPOLAR

TRANSISTOR(IGBT)- BASIC

CONSTRUCTION-

The n+ layer substrate at the drain in the power MOSFET is substituted by p+ layer substrate and called as collector. When gate to emitter voltage is positive, n- channel is formed in the p- region. This n- channel short circuit the n- and n+ layer and an electron movement in n channel cause hole injection from p+ substrate layer to n- layer.

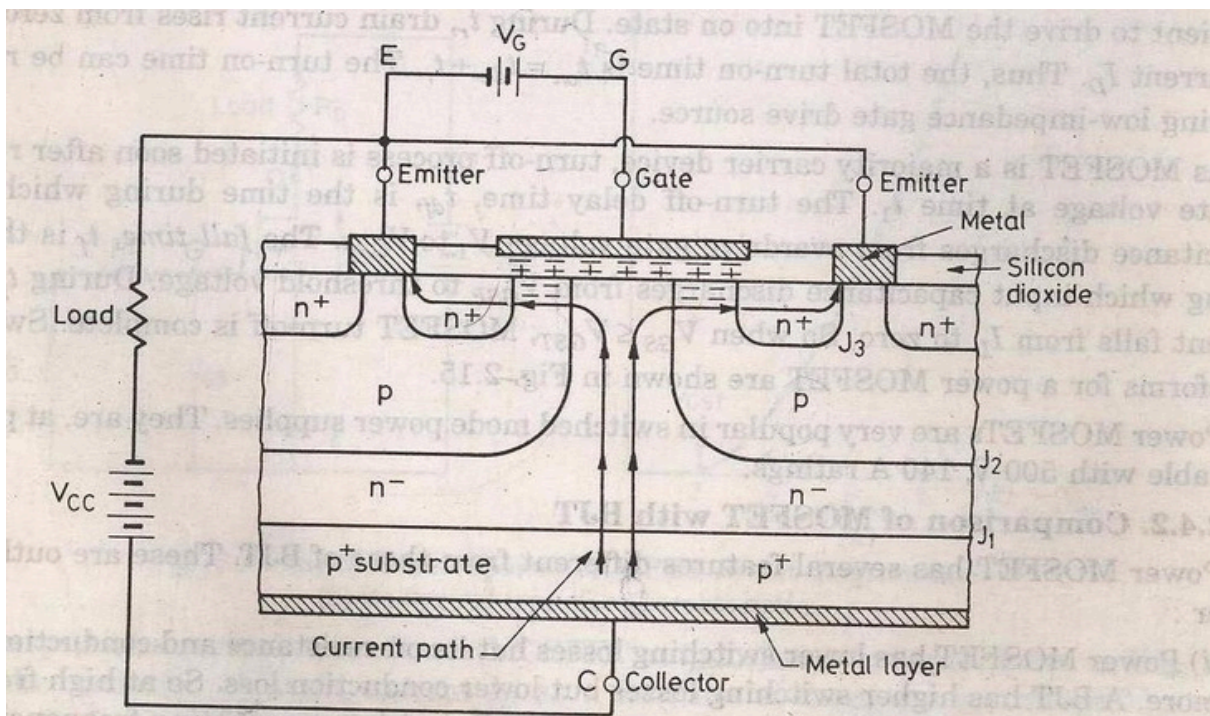

POWER MOSFET

A power MOSFET has three terminal device. Arrow indicates the direction of current flow. MOSFET is a voltage controlled device. The operation of MOSFET depends on flow of majority carriers only.

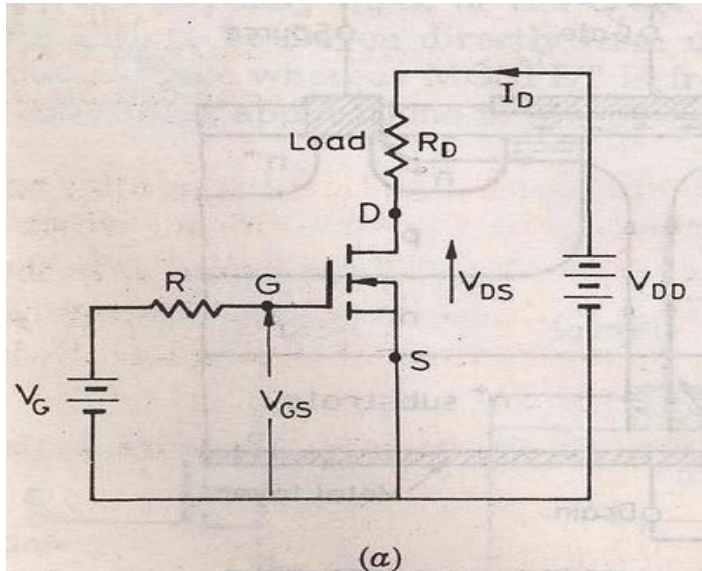

(Circuit diagram)

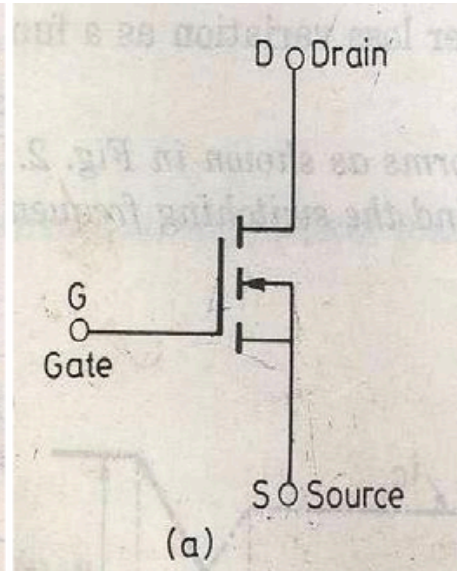

(circuit symbol)

Switching Characteristics:-

The switching characteristic is influenced by

1. Internal capacitance of the device.
2. Internal impedance of the gate drive

circuit. Total **turn on time** is divided into

1. Turn on delay time
2. Rise time

Turn on time is affected by impedance of gate drive source. During turn on delay time gate to source voltage attains its threshold value V_{GST} .

After t_{dn} and during rise time gate to source voltage rise to V_{Gsp} , a voltage which is sufficient to drive the MOSFET to ON state.

The turn off process is initiated by removing the gate to source voltage. Turn off time is composed of turn off delay time to fall time.

Turn off delay time

To turn off the MOSFET the input capacitance has to be discharged . During t_{df} the input capacitance discharge from V_1 to V_{Gsp} . During t_f , fall time ,the input capacitance discharges from V_{Gsp} to V_{GST} . During t_f drain current falls from I_D to zero.

So when $V_{GS} \leq V_{GS}$, MOSFET turn off is complete.

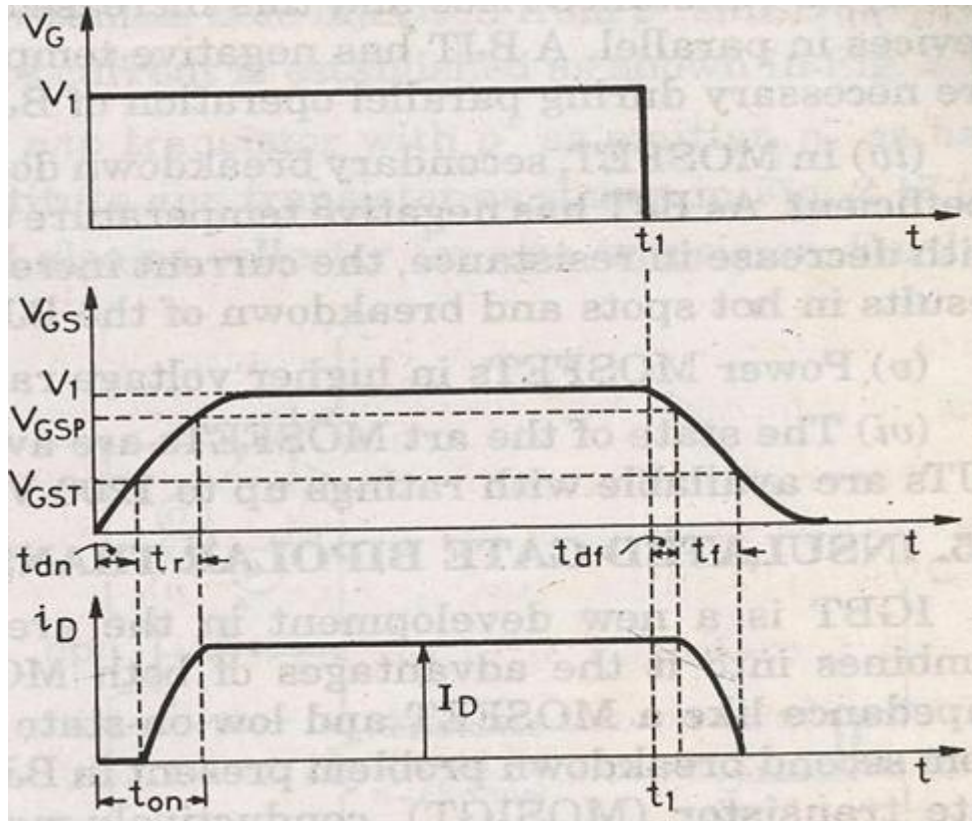

Fig. Switching waveform of power MOSFET

Insulated Gate Bipolar Transistor (IGBT)

IGBT has high input impedance like MOSFET and low on state power loss as in BJT.

IGBT Characteristics

Here the controlling parameter is gate emitter voltage As IGBT is a voltage controlled device.

When V_{GE} is less than V_{GET} that is gate emitter threshold voltage IGBT is in off state.

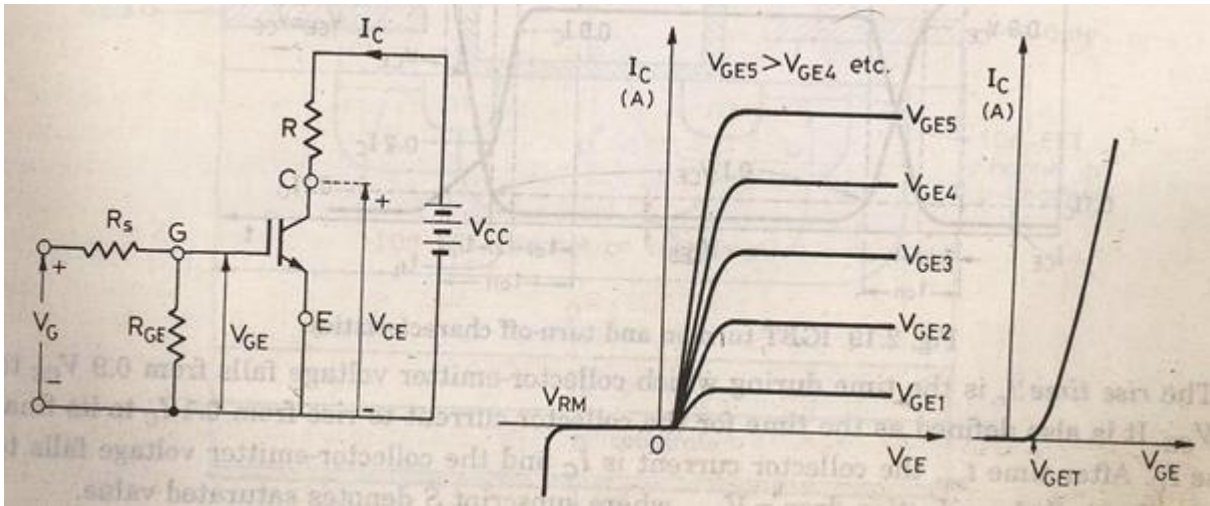

Fig. a

Fig. b.

Fig. c

Fig. a (Circuit diagram for obtaining V-I characteristics)

Fig. b (Static V-I characteristics)

Fig. c (Transfer characteristic)

Switching characteristics : Figure below shows the turn ON and turn OFF characteristics of IGBT

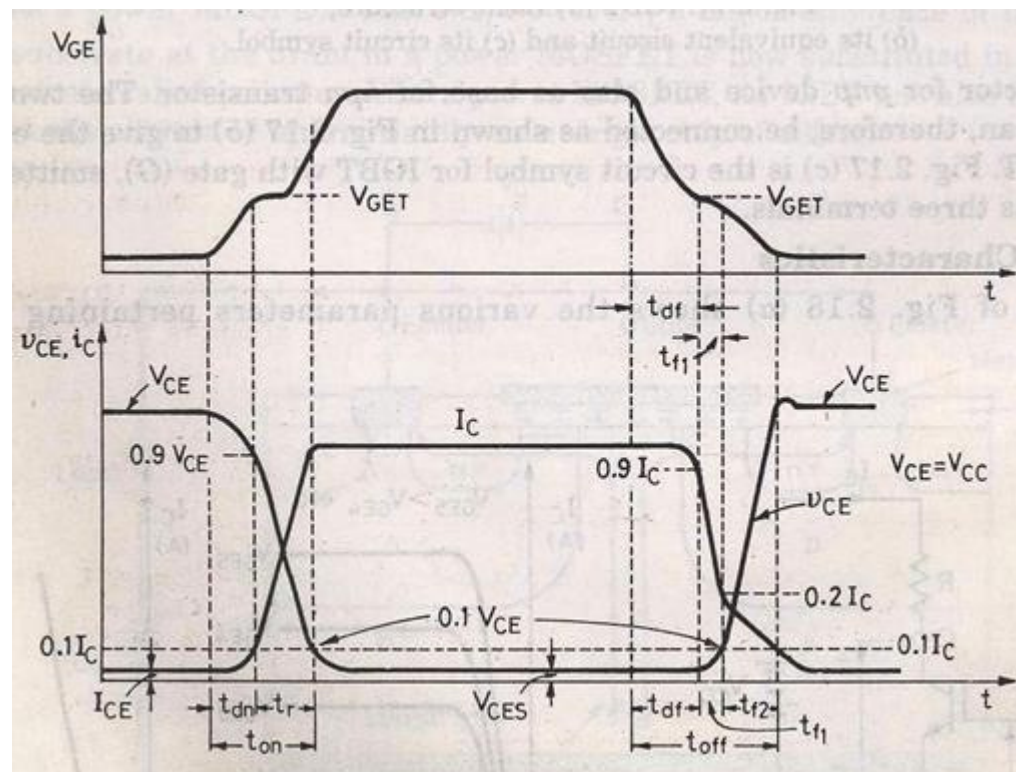

Turn on time

Time between the instants forward blocking state to forward on -state .

Turn on time = Delay time + Rise time

Delay time = Time for collector emitter voltage fall from V_{CE} to $0.9V_{CE}$

V_{CE} = Initial collector emitter voltage

t_{dn} = collector current to rise from initial leakage current to $0.1I_c$

I_c = Final value of collector current

Rise time

Collector emitter voltage to fall from $0.9V_{CE}$ to $0.1V_{CE}$.

I_c to I_c

After t_{on} the device is on state the device carries a steady current of I_c and the collector emitter voltage falls to a small value called conduction drop V_{CES} .

Turn off time

- 1 Delay time t_d
-) Initial fall time t_{f1}
- 2 Final fall time t_{f2}
-)
- 3 $t_{Off} = t_d + t_{f1} + t_{f2}$
-)

t_d = Time during which the gate emitter voltage falls to the threshold value V_{GET} .

Collector current falls from I_c to $0.9I_c$ at the end of t_{f1} collector emitter voltage begins to rise.

Turn off time = Collector current falls from 90% to 20% of its initial value I_c OR The time during which collector emitter voltage rise from V_{CE} to $0.1V_{CE}$.

t_{f2} = collector current falls from 20% to 10% of I_c .

During this collector emitter voltage rise $0.1V_{CE}$ to final value of V_{CE} .

Series and parallel operation of SCR

SCR are connected in series for h.v demand and in parallel for fulfilling high current demand. String efficiency can be defined as measure of the degree of utilization on SCRs in a string.

String efficiency < 1.

Derating factor (DRF)

1 – string efficiency.

If DRF more then

no. of SCRs will more, so string is more reliable.

Let the rated blocking voltage of the string of a series connected SCR is $2V_1$ as shown in the figure below, But in the string two SCRs are supplied a maximum voltage of V_1+V_2 .

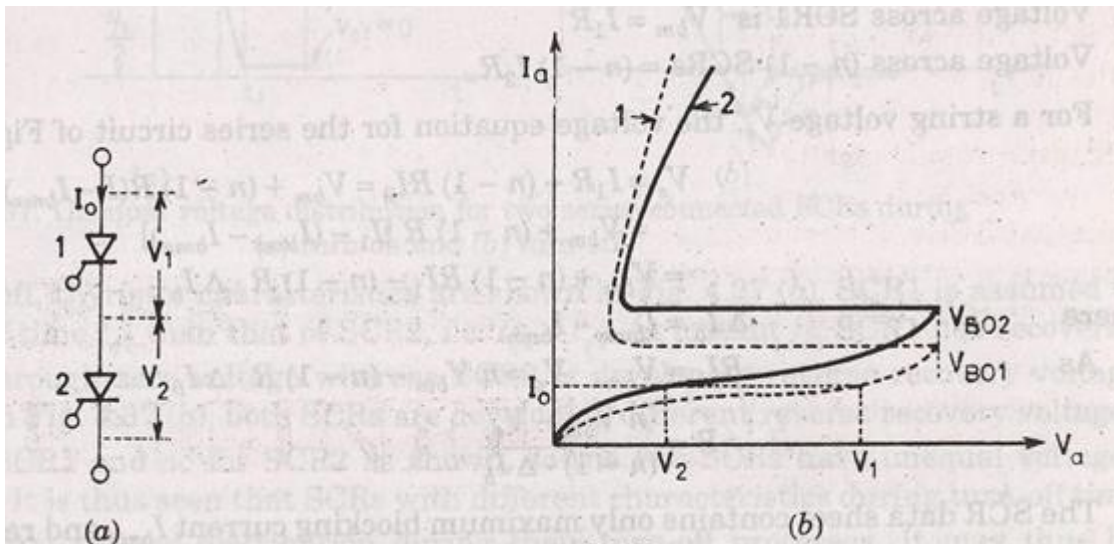

$$\eta = \frac{V_1 + V_2}{2V_1}$$

Significance of string efficiency . Two SCRs are have same forward blocking

voltage ,When system voltage is more then the voltage rating of a single SCR. SCRs are connected in series in a string.

There is a inherent variation in characteristics. So voltage shared by each SCR may not be

equal. Suppose, SCR1 leakage resistance > SCR2 leakage resistance. For same leakage current I_o in the series connected SCRs. For same leakage current SCR1 supports a

voltage $\frac{V_1}{2}$ and SCR2 supports a voltage $\frac{V_2}{2}$.

So, $V_1 > V_2$.
So string η for two SCRs = $\frac{V_1 + V_2}{2V_1} = 1 + \frac{V_2}{2V_1} < 1$.

The above operation is when SCRs are not turned ON. But in steady state of operation , A uniform voltage distribution in the state can be achieved by connect a suitable resistance across each SCRs , so that parallel combination have same resistance.

But this is a cumbersome work. During steady state operation we connect same value of shunt resistance across each SCRs. This shunt resistance is called **state equalizing circuit**.

Suppose,

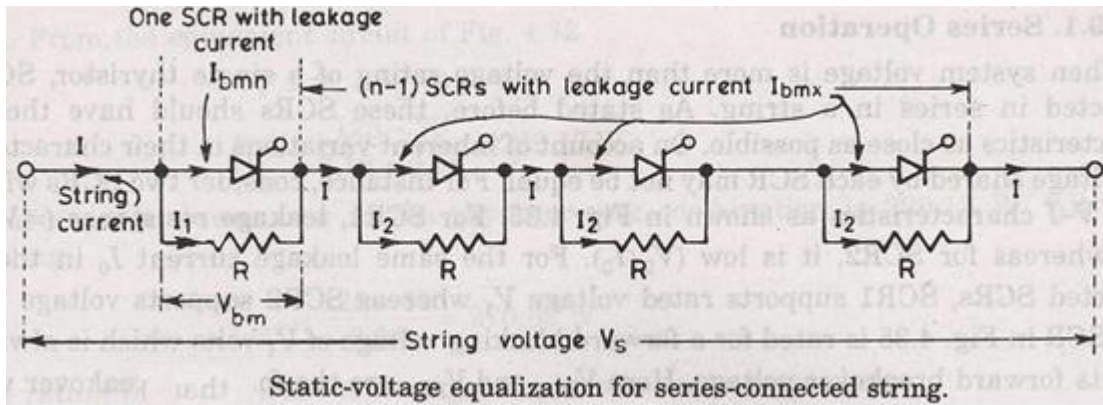

Let SCR1 has lower leakage current I_{bm} , It will block a voltage comparatively larger than other SCRs.

Voltage across SCR1 is $V_{bm} = I_1 R$.

Voltage across (n-1)SCR is (n-1) $I_2 R$, so the voltage equation for the series circuit is $V_s = I_1 R + (n-1) I_2 R = V_{bm} + (n-1) R (I - I_{bmx})$

As $I_1 = I - I_{bmn}$

$$I_2 = I - I_{bmx}$$

So, $V_s = V_{bm} + (n-1) R [I_1 - (I_{bmx} - I_{bmn})]$ If

$$\Delta I_b = I_{bmx} - I_{bmn}$$

Then $V_s = V_{bm} + (n-1) R (I_1 - \Delta I_b)$

$$V_s = V_{bm} + (n-1) R I_1 - (n-1) R \Delta I_b$$

$$R I_1 = V_{bm}$$

So, $V_s = V_{bm} + (n-1) V_{bm} - (n-1) R \Delta I_b$

$$= n V_{bm} - (n-1) R \Delta I_b$$

$$\Rightarrow R = \frac{n V_{bm} = V_s}{(n-1) \Delta I_b}$$

SCR data sheet usually contain only maximum blocking current, I_{bmx}

so we assume $I_{bmn} = 0$

So $\Delta I_b = I_{bmx}$

So the value of R calculated is low than actually required.

SCRs having unequal dynamic characteristics :

It may occur that SCRS may have unequal dynamic characteristics so the voltage distribution across the SCR may be unequal during the transient condition.

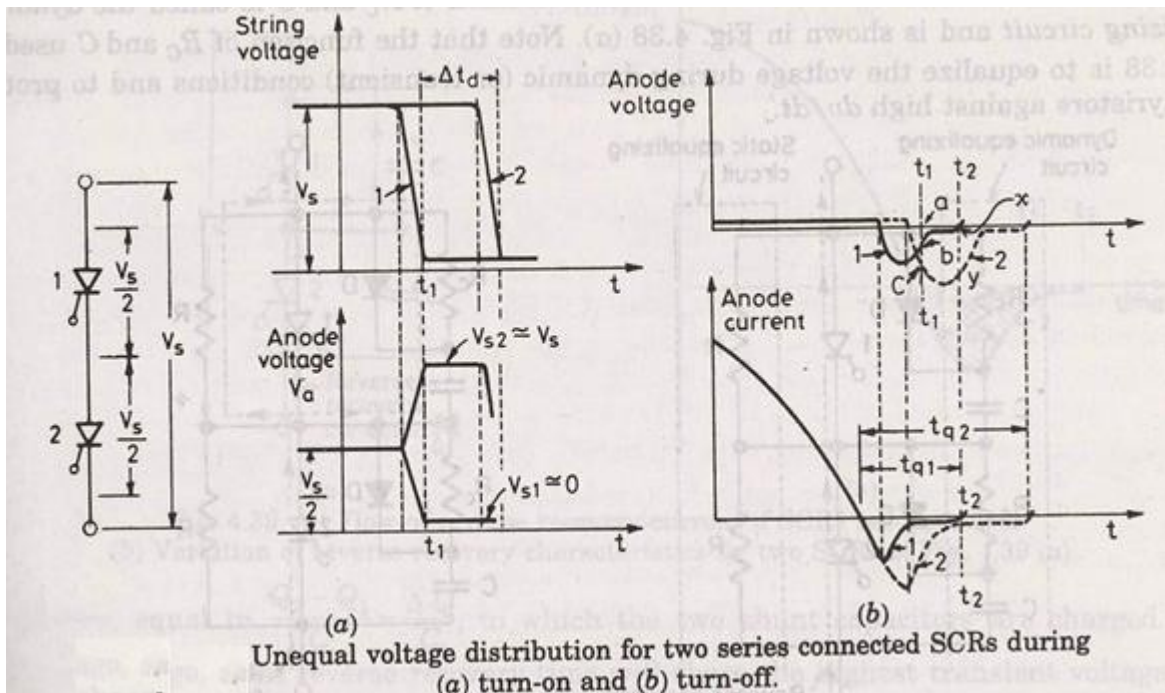

SCR 1 and SCR 2 have different dynamic characteristics. Turn ON time of SCR 2 is more than SCR 1 by time Δt .

As string voltage is V_S so voltage shared by each SCRs be $V_S/2$. Now both are gated at same time so SCR 1 will turn ON at t_1 its voltage fall nearly to zero so the voltage shared by SCR 2 will be the string voltage if the break over voltage of SCR 2 is less than V_S then SCR 2 will turn ON.

* In case V_S is less than the breakover voltage, SCR 2 will turn ON at instant 2. SCR 1 time then SCR 2, so $t_{q1} < t_{q2}$. At t_2 SCR 1 has recovered assumed to have less turn off t_q while SCR 2 is developing recovery voltage at t_1 both are developing different reverse

recovery voltage.

At t_2 SCR 1 has recovered while SCR2 is developing reverse recovery voltage.

Conclusion :

* Series connected SCR develop different voltages during turn ON and turn OFF process. Till now we connect a simple resistor across the diode for static voltage equalizing circuit.

*During turn ON and turn OFF capacitance of reverse biased junction determine the voltage distribution across SCRs in a series connected string. As reverse biased junction have different capacitance called *self capacitance*, the voltage distribution during turn ON and turn Off process would be different.

*Under transient condition equal voltage distribution can be achieved by employing shunt capacitance as this shunt capacitance has the effect of that the resultant of shunt and self capacitance tend to be equal. The capacitor is used to limits the dv/dt across the SCR during forward blocking state. When this SCR turned ON capacitor discharges heavy current through the SCR . The discharge current spike is limited by damping resistor R . R_c also damps out high frequency oscillation that may arise due to series combination of R , C and series inductor . R_c & C are called *dynamic equalizing circuit*

Diode D is used during forward biased condition for more effective charging of the capacitor. During capacitor discharge R_c comes into action for limiting current spike and rate of change of current di/dt .

The R , R_c & C component also provide path to flow reverse recovery current. When one SCR regain its voltage blocking capability. The flow of reverse recovery current is necessary as it facilitates the turning OFF process of series connected SCR string. So C is necessary for both during turn ON and turn OFF process. But the voltage unbalance during turn OFF time is more predominant then turn ON time. So choice of C is based on reverse recovery characteristic of SCR .

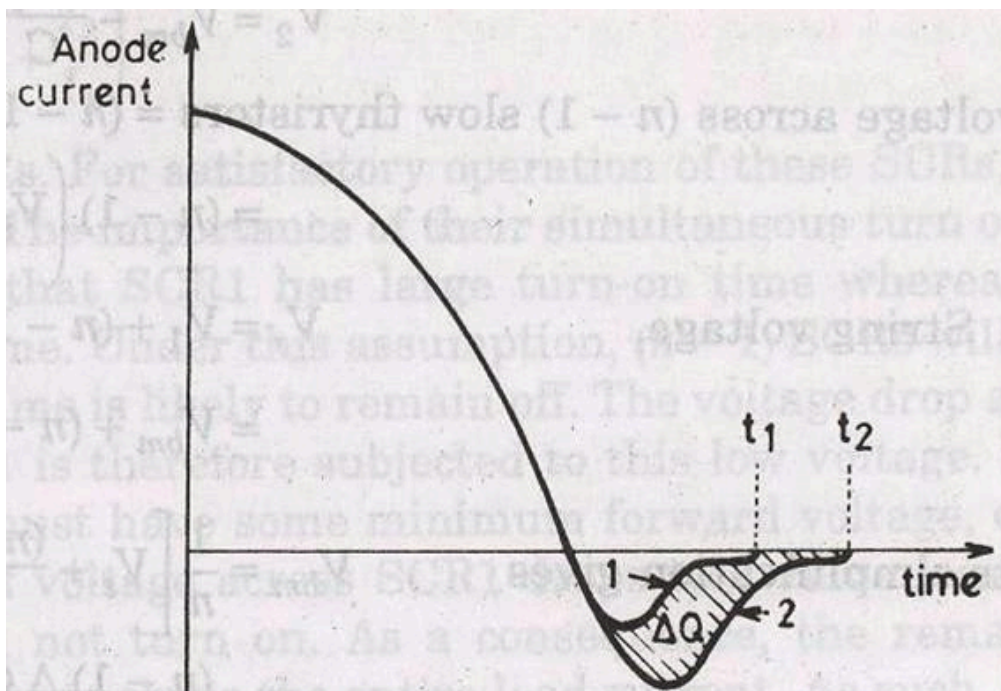

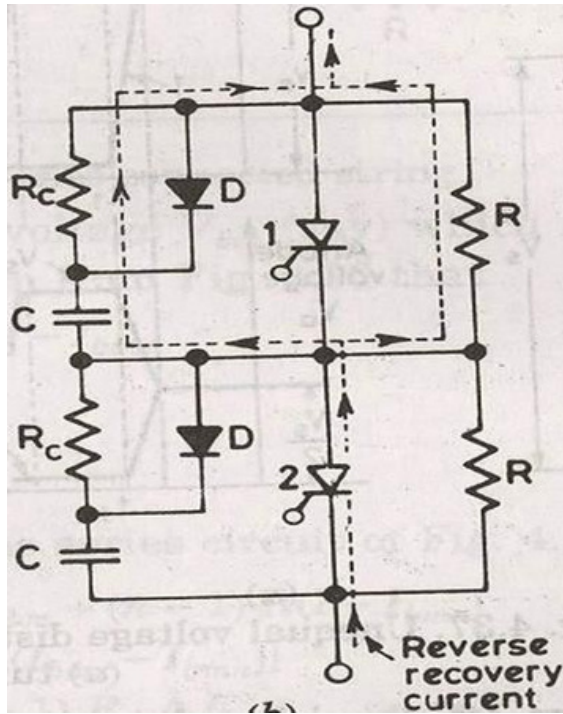

SCR 1 has short recovery time as compared to SCR 2. ΔQ is the difference in reverse recovery charges of two SCR 1 and SCR 2. Now we assume the SCR 1 recovers fast . i.e it goes into blocking state so charge ΔQ can pass through C . The voltage induced by c_1 is $\Delta Q/C$, where is no voltage induced across C_2 .

The difference in voltage to which the two shunt capacitor are charged $\Delta Q/C$.

Now thyristor with least recovery time will share the highest transient voltage say V_{bm} ,

So, $V_{bm} - V_2 = \Delta Q/C$

So, $V_2 = V_{bm} - \Delta Q/C$

As $V_1 = V_{bm}$

$$V_s = V_1 + V_2$$

$$= V_{bm} + (V_{bm} - \Delta Q/C)$$

$$V_s = 2V_{bm} - \Delta Q/C$$

$$\Rightarrow \frac{1}{2} (+ \frac{\Delta Q}{C}) = V_{bm}$$

$$\Rightarrow 2 = V_{bm} - \Delta Q/C$$

$$\frac{1}{2} [V_s - \Delta Q/C]$$

2

Now suppose that there are n series SCRs in a string.

Let us assume that if top SCR has similar to characteristic SCR 1. Then SCR 1 would support a voltage V_{bm}

* If the remaining $(n-1)$ SCR has characteristic that of SCR 2. Then SCR 1 would recover first and support a voltage V_{bm} . The charge $(n-1) \Delta Q$ from the remaining $(n-1)$ SCR would pass through C.

$$V_1 = V_{bm}$$

$$V_2 = V_{bm} - \Delta Q/C$$

Voltage across $(n-1)$ slow thyristors

$$V = (n-1) (V_{bm} - \Delta Q/C)$$

So, $V_S = V_1 + (n-1) V_2$

$$= V_{bm} + (n-1) (V_{bm} - \Delta Q/C)$$

By simplifying we get ,

$$V_{bm} = \frac{1}{n} [V_S + (n-1) \Delta Q/C]$$

$$C = [(n-1) \Delta Q / (nV_{bm} - V_S)]$$

$$V_2 = (V_S - \Delta Q/C) / n .$$

Parallel operation :

When current required by the load is more than the rated current of single thyristor , SCRs are connected in parallel in a string .

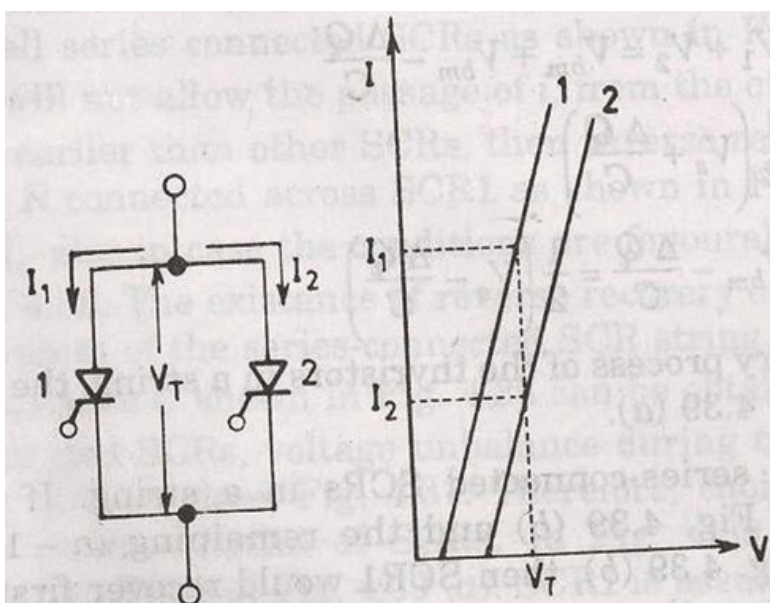

Curve 2 highest possible voltage values that can be safely applied to get circuit.

V_{gm} = Maximum limit for gate voltage .

I_{gm} = Maximum limit for gate current.

P_{gav} = Rated gate power dissipation for each SCR.

These limits should not be crossed in order to avoid the permanent damage of the device junction J_3 .

OY = Minimum limit of gate voltage to turn ON .

OX = minimum limit of gate current to turn ON.

If V_{gm} , I_{gm} , P_{gav} are exceeded the thyristor will damage so the preferred gate drive area of SCR is bcdefghb.

oa = The non triggering gate voltage , If firing circuit generates +ve gate signal prior to the desired instant of triggering the SCR. It should be ensured that this unwanted signal should be less than the non –triggering voltage oa.

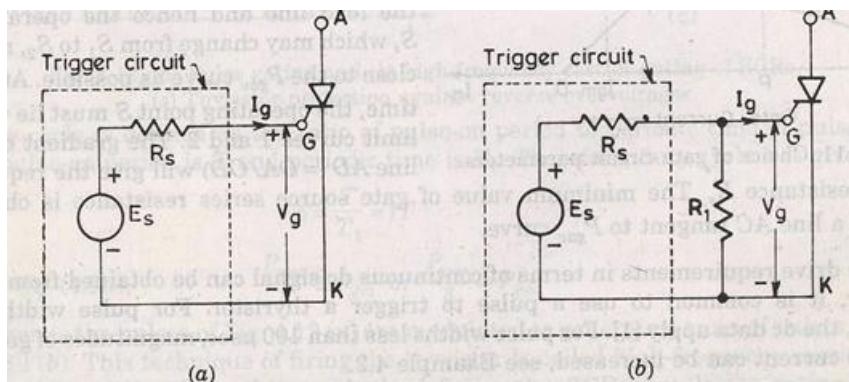

$$E_s = V_g + I_g R_s$$

E_s = Gate source voltage

V_g = Gate cathode voltage

I_g = Gate current

R_s = Gate source resistance

R_1 = The internal resistance of the trigger source

R_1 is connected across the gate cathode terminal, which provides an easy path to the flow of leakage current between SCR terminal I_{gmn} , V_{gmn} are the minimum gate current and gate voltage to turn ON the SCR.

$$E_s = (I_{gmn} + V_{gmn} / R_1) R_s + V_{gmn}$$

MODULE-2

UNDERSTAND THE WORKING OF CONVERTERS, AC REGULATORS AND CHOPPERS CONTROLLED RECTIFIER

Rectifier are used to convert A.C to D.C supply. Rectifiers can be classified as single phase rectifier and three phase rectifier. Single phase rectifier are classified as 1- Φ half wave and 1- Φ full wave rectifier. Three phase rectifier are classified as 3- Φ half wave rectifier and 3- Φ full wave rectifier. 1- Φ Full wave rectifier are classified as 1- Φ mid point type and 1- Φ bridge type rectifier. 1- Φ bridge type rectifier are classified as 1- Φ half controlled and 1- Φ full controlled rectifier. 3- Φ full wave rectifier are again classified as 3- Φ mid point type and 3- Φ bridge type rectifier. 3- Φ bridge type rectifier are again divided as 3- Φ half controlled rectifier and 3- Φ full controlled rectifier

Single phase half wave circuit with R load:

6.1. PRINCIPLE OF PHASE CONTROL

The simplest form of controlled rectifier circuits consist of a single thyristor feeding dc power to a resistive load R as shown in Fig. 6.1 (a). The source voltage is $v_s = V_m \sin \omega t$, Fig. 6.1 (b). An SCR can conduct only when anode voltage is positive and a gating signal is applied. As such, a thyristor blocks the flow of load current i_o until it is triggered. At some delay angle α , a positive gate signal applied between gate and cathode turns on the SCR, immediately, full supply voltage is applied to the load as v_o , Fig. 6.1 (b). At the instant of delay angle α , v_o rises from zero to $V_m \sin \alpha$ as shown. For resistive load, current i_o is in phase with v_o . Firing angle of a thyristor is measured from the instant it would start conducting if it were replaced by a diode. In Fig. 6.1, if thyristor is replaced by diode, it would begin conduction at $\omega t = 0, 2\pi, 4\pi$ etc.; firing angle is therefore measured from these instants. A *firing angle* may thus be defined as the angle between the instant thyristor would conduct if it were a diode and the instant it is triggered.

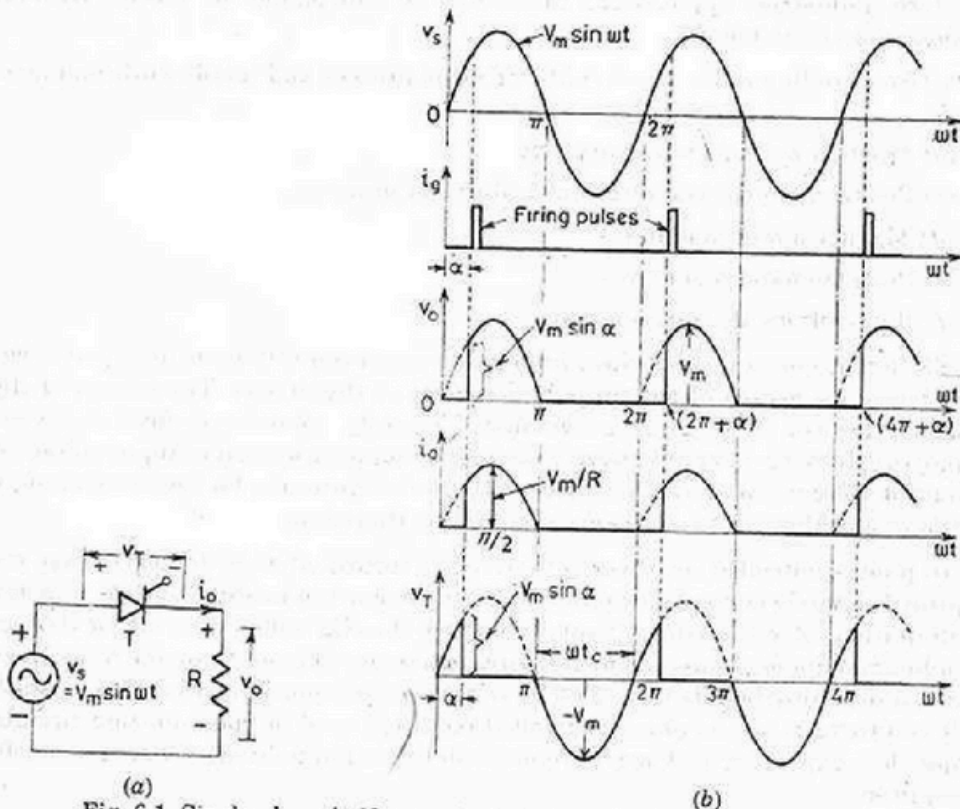

Fig. 6.1. Single-phase half-wave thyristor circuit with R load
(a) circuit diagram and (b) voltage and current waveforms.

A firing angle may also be defined as follows: A *firing angle* is measured from the angle that gives the largest average output voltage, or the highest load voltage. If thyristor in Fig. 6.1 is fired at $\omega t = 0, 2\pi, 4\pi$ etc., the average load voltage is the highest; the firing angle should thus be measured from these instants. A *firing angle* may thus be defined as the angle measured from the instant that gives the largest average output voltage to the instant it is triggered.

Once the SCR is on, load current flows, until it is turned-off by reversal of voltage at $\omega t = \pi, 3\pi$ etc. At these angles of $\pi, 3\pi, 5\pi$ etc. load current falls to zero and soon after the supply voltage reverse biases the SCR, the device is therefore turned off. It is seen from Fig. 6.1 (b) that by varying the firing angle α , the *phase* relationship between the start of the load current and the supply voltage can be *controlled*; hence the term *phase control* is used for such a method of controlling the load currents [3].

A single-phase half-wave circuit is one which produces only *one* pulse of load current during one cycle of source voltage. As the circuit shown in Fig. 6.1 (a) produces only one load current pulse for one cycle of sinusoidal source voltage, this circuit represents a single-phase half-wave thyristor circuit.

In Fig. 6.1 (b), thyristor conducts from $\omega t = \alpha$ to $\pi, (2\pi + \alpha)$ to 3π and so on. Over the firing angle delay α , load voltage $v_o = 0$ but during conduction angle $(\pi - \alpha), v_o = v_s$. As firing angle is increased from zero to π , the average load voltage decreases from the largest value to zero.

The variation of voltage across thyristor is also shown as v_T in Fig. 6.1 (b). Thyristor remains on from $\omega t = \alpha$ to $\pi, (2\pi + \alpha)$ to 3π etc., during these intervals $v_T = 0$ (strictly speaking 1 to 1.5 V). It is off from π to $(2\pi + \alpha), 3\pi$ to $(4\pi + \alpha)$ etc., during these off intervals v_T has the waveshape of supply voltage v_s . It may be observed that $v_s = v_o + v_T$. As the thyristor is reverse biased for π radians, the circuit turn-off time is given by

$$t_c = \frac{\pi}{\omega} \text{ sec}$$

where $\omega = 2\pi f$ and f is the supply frequency in Hz.

The circuit turn-off time t_c must be than the SCR turn-off time t_q as specified by the manufacturers.

Average voltage V_o across load R in Fig. 6.1 for the single-phase half-wave circuit in terms of firing angle α is given by

$$V_o = \frac{1}{2\pi} \int_{\alpha}^{\pi} V_m \sin \omega t \cdot d(\omega t) = \frac{V_m}{2\pi} (1 + \cos \alpha) \quad \dots(6.1)$$

The maximum value of V_o occurs at $\alpha = 0^\circ$.

$$\therefore V_{o-m} = \frac{V_m}{2\pi} \cdot 2 = \frac{V_m}{\pi}$$

$$\text{Average load current, } I_o = \frac{V_o}{R} = \frac{V_m}{2\pi R} (1 + \cos \alpha) \quad \dots(6.2)$$

Single phase half wave circuit with R-L load

A single-phase half-wave thyristor circuit with RL load is shown in Fig. 6.2 (a). Line voltage v_s is sketched in the top of Fig. 6.2 (b). At $\omega t = \alpha$, thyristor is turned on by gating signal. The load voltage v_o at once becomes equal to source voltage v_s , as shown. But the inductance L forces the load, or output, current i_o to rise gradually. After some time, i_o reaches maximum value and then begins to decrease. At $\omega t = \pi$, v_o is zero but i_o is not zero because of the load inductance L . After $\omega t = \pi$, SCR is subjected to reverse anode voltage but it will not be turned off as load current i_o is not less than the holding current. At some angle $\beta > \pi$, i_o reduces to zero and SCR is turned off as it is already reverse biased. After $\omega t = \beta$, $v_o = 0$ and $i_o = 0$. At $\omega t = 2\pi + \alpha$, SCR is triggered again, v_o is applied to the load and load

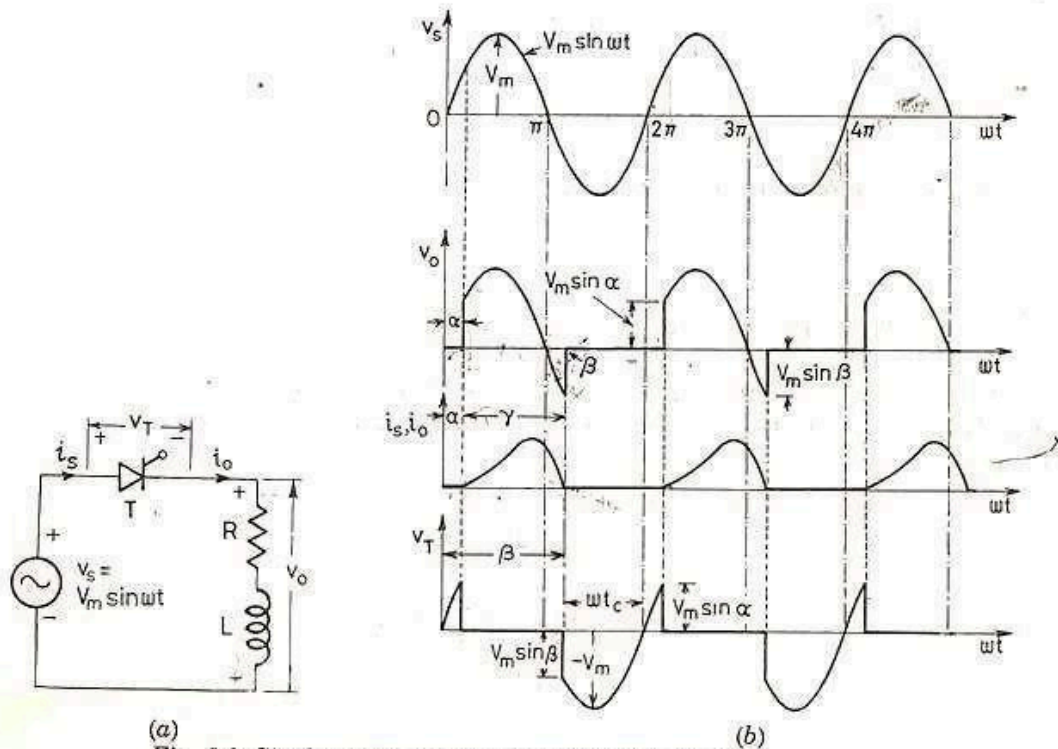

(a) (b)
Fig. 6.2. Single-phase half-wave circuit with RL load
(a) circuit diagram and (b) voltage and current waveforms.

current develops as before. Angle β is called the *extinction angle* and $(\beta - \alpha) = \gamma$ is called the *conduction angle*.

The waveform of voltage v_T across thyristor T in Fig. 6.2 (b) reveals that when $\omega t = \alpha$, $v_T = V_m \sin \alpha$; from $\omega t = \alpha$ to β , $v_T = 0$ and at $\omega t = \beta$, $v_T = V_m \sin \beta$. As $\beta > \pi$, v_T is negative at $\omega t = \beta$. Thyristor is therefore reverse biased from $\omega t = \beta$ to 2π . Thus, circuit turn-off time $t_C = \frac{2\pi - \beta}{\omega}$ sec. For satisfactory commutation, t_C should be more than t_q the thyristor turn-off time.

The voltage equation for the circuit of Fig. 6.2 (a) is

$$V_m \sin \omega t = R i_0 + L \frac{di_0}{dt}$$

The load current i_0 consists of two components, one steady-state component i_s and the other transient component i_t . Here i_s is given by

$$i_s = \frac{V_m}{\sqrt{R^2 + X^2}} \sin (\omega t - \phi)$$

where $\phi = \tan^{-1} \frac{X}{R}$ and $X = \omega L$. Here ϕ is the angle by which rms current I_s lags V_s .

The transient component i_t can be obtained from force-free equation

$$R i_t + L \frac{di_t}{dt} = 0$$

Its solution gives,

$$i_t = A e^{-(R/L)t}$$

\therefore

$$i_0 = i_s + i_t = \frac{V_m}{Z} \sin (\omega t - \phi) + A e^{-(R/L)t} \quad \dots(6.6)$$

where

$$Z = \sqrt{R^2 + X^2}$$

$$V_0 = \frac{1}{2\pi} \int_{\alpha}^{\beta} V_m \sin \omega t \, d(\omega t) = \frac{V_m}{2\pi} (\cos \alpha - \cos \beta) \quad \dots(6.8)$$

$$\text{Average load current, } I_0 = \frac{V_m}{2\pi R} (\cos \alpha - \cos \beta) \quad \dots(6.9)$$

$$\begin{aligned} \text{Rms load voltage, } V_{or} &= \left[\frac{1}{2\pi} \int_{\alpha}^{\beta} V_m^2 \sin^2 \omega t \cdot d(\omega t) \right]^{1/2} \\ &= \frac{V_m}{2\sqrt{\pi}} \left[(\beta - \alpha) - \frac{1}{2} (\sin 2\beta - \sin 2\alpha) \right]^{1/2} \quad \dots(6.10) \end{aligned}$$

Rms load current can be obtained from Eq. (6.7) if required.

6.1.2. Single-phase Half-wave Circuit with RL Load and Freewheeling Diode

The waveform of load current i_0 in Fig. 6.2 (b) can be improved by connecting a freewheeling (or flywheeling) diode across load as shown in Fig. 6.3 (a). A freewheeling diode is also called by-pass or commutating diode. At $\omega t = 0$, source voltage is becoming positive. At some delay angle α , forward biased SCR is triggered and source voltage v_s appears across load as v_0 . At $\omega t = \pi$, source voltage v_s is zero and just after this instant, as v_s tends to reverse, freewheeling diode FD is forward biased through the conducting SCR. As a result, load current i_0 is immediately transferred from SCR to FD as v_s tends to reverse. At the same time, SCR

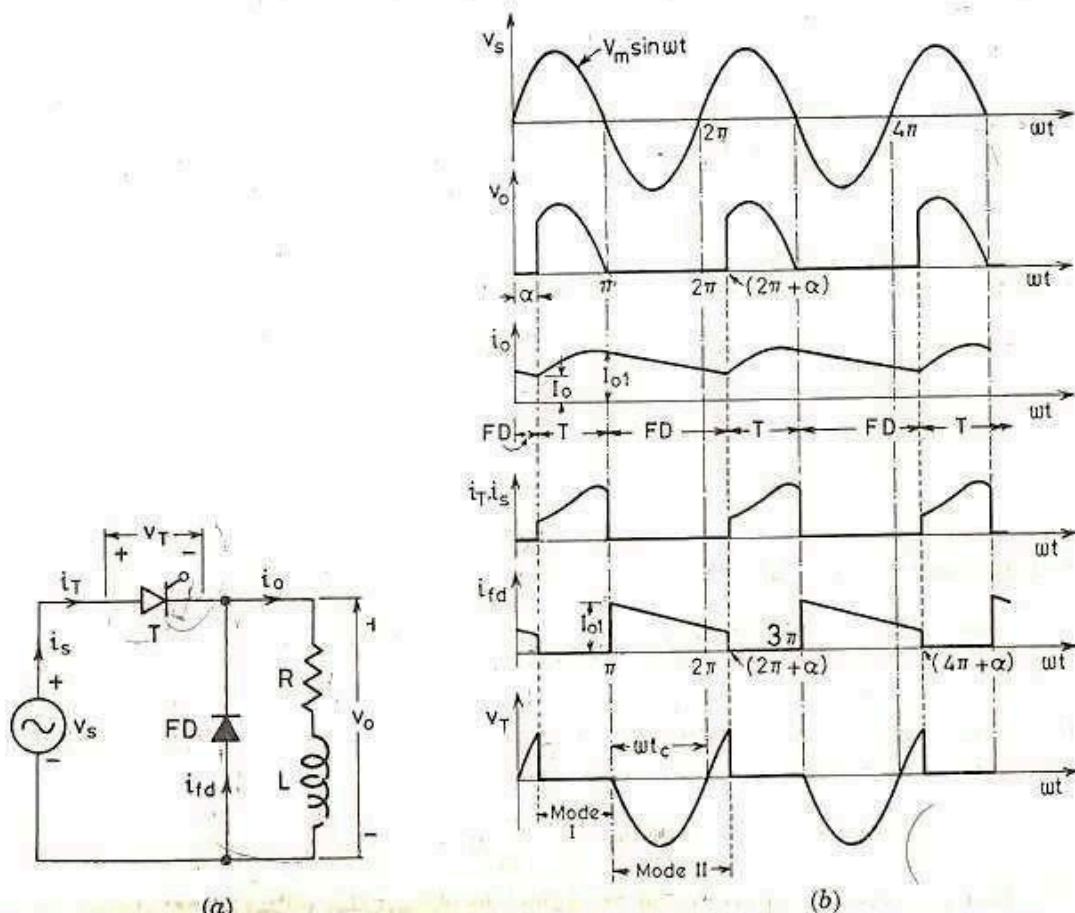

Fig. 6.3. Single-phase half-wave circuit with RL load and a freewheeling diode, (a) circuit diagram and (b) voltage and current waveforms.

is subjected to reverse voltage and zero current, it is therefore turned off at $\omega t = \pi$. It is assumed that during freewheeling period load current does not decay to zero until the SCR is triggered again at $(2\pi + \alpha)$. Voltage drop across FD is taken as almost zero, the load voltage v_o is, therefore, zero during the freewheeling period. The voltage variation across SCR is shown as v_T in Fig. 6.3 (b). It is seen from this wave-form that SCR is reverse biased from $\omega t = \pi$ to $\omega t = 2\pi$. Therefore, circuit turn-off time is

$$t_C = \frac{\pi}{\omega} \text{ sec}$$

The source current i_s and thyristor current i_T have the same waveform as shown.

Operation of the circuit of Fig. 6.3 (a) can be explained in two modes. In the first mode, called *conduction mode*, SCR conducts from α to π , $2\pi + \alpha$ to 3π and so on and FD is reverse biased. The duration of this mode is for $[(\pi - \alpha)/\omega]$ sec. Let the load current at the beginning of mode I be I_0 . The expression for current i_0 in mode I can be obtained as follows :

Mode I : For conduction mode, the voltage equation is

$$V_m \sin \omega t = Ri_0 + L \frac{di_0}{dt}$$

Its solution, already obtained in the previous section, is repeated here from Eq. (6.6) as

$$i_0 = \frac{V_m}{Z} \sin (\omega t - \phi) + A e^{-1(R/L)t}$$

At $\omega t = \alpha$, $i_0 = I_0$, i.e. at $t = \frac{\alpha}{\omega}$, $i_0 = I_0$

Note that for mode I, $\alpha \leq \omega t \leq \pi$

Mode II : This mode, called freewheeling mode, extends from π to $2\pi + \alpha$, 3π to $4\pi + \alpha$ and so on. In this mode, SCR is reverse biased from π to 2π , 3π to 4π ... as shown by voltage waveform v_T in Fig 6.3 (b). As the load current is assumed continuous, FD conducts from π to $(2\pi + \alpha)$, 3π to $(4\pi + \alpha)$ and so on. Let the current at the beginning of mode II be I_{01} as shown. As load current is passing through FD, the voltage equation for mode II is

$$0 = Ri_0 + L \frac{di_0}{dt}$$

Its solution is

$$i_0 = A e^{-(R/L)t}$$

At $\omega t = \pi$,

$$i_0 = I_{01}$$

It gives

$$A = I_{01} e^{R\pi/\omega L}$$

\therefore

$$i_0 = I_{01} \cdot \exp \left[-\frac{R}{L} \left(t - \frac{\pi}{\omega} \right) \right] \quad \dots(6.12)$$

Note that for mode II,

$$\pi < \omega t \leq (2\pi + \alpha)$$

Average load voltage V_0 from Fig. 6.3 (b) is given by

$$V_0 = \frac{1}{2\pi} \int_{\alpha}^{\pi} V_m \sin \omega t d(\omega t) = \frac{V_m}{2\pi} (1 + \cos \alpha) \quad \dots(6.13)$$

2,3 Understand need of freewheeling diode

$$\text{Average load current, } \bar{i}_0 = \frac{V_0}{R} = \frac{V_m}{2\pi R} (1 + \cos \alpha) \quad \dots(6.14)$$

Note that load current i_0 is contributed by SCR from α to π , $(2\pi + \alpha)$ to 3π and so on and by FD from 0 to α , π to $(2\pi + \alpha)$ and so on. Thus the waveshape of thyristor current i_T is identical with the waveshape of i_0 for $\omega t = \alpha$ to π , $(2\pi + \alpha)$ to 3π and so on. Similarly, the wave shape of FD current i_{fd} is identical with the waveform of i_0 for $\omega t = 0^\circ$ to α , π to $(2\pi + \alpha)$ and so on.

In Fig. 6.2, load consumes power p_1 from source for α to π (both v_0 and i_0 are positive) whereas energy stored in inductance L is returned to the source as power p_2 for π to β (v_0 is negative and i_0 is positive). As a result, net power consumed by the load is the difference of these two powers p_1 and p_2 . In Fig. 6.3, load absorbs power for α to π , but for π to $(2\pi + \alpha)$, energy stored in L is delivered to load resistance R through the FD. As a consequence, power consumed by load is more in Fig. 6.3. It can, therefore, be concluded that power delivered to load, for the same firing angle, is more when FD is used. As volt-ampere input is almost the same in both Figs. 6.2 and 6.3, the input pf (= power delivered to load/input volt-ampere) with the use of FD is improved.

It is also seen from Figs. 6.2 (b) and 6.3 (b) that load current waveform is improved with FD in Fig. 6.3 (b). Thus the advantages of using freewheeling diode are

- (i) input pf is improved
- (ii) load current waveform is improved and
- (iii) as a result of (ii), load performance is better.

It may be seen from Fig. 6.3 (b) that freewheeling diode prevents the load voltage v_0 from becoming negative. Whenever load voltage tends to go negative, FD comes into play. As a result, load current is transferred from main thyristor to FD, allowing the thyristor to regain its forward blocking capability.

It is seen from Figs. 6.2 (b) and 6.3 (b) that supply current i_s taken from the source is unidirectional and is in the form of dc pulses. Single phase half-wave converter thus introduces a dc component into the supply line. This is undesirable as it leads to saturation of the supply transformer and other difficulties (harmonics etc.).

These shortcomings can be overcome to some extent by the use of single-phase fullwave circuits discussed in Art. 6.2.

Single phase Fully Controlled Converter

① midraht fire with R load →

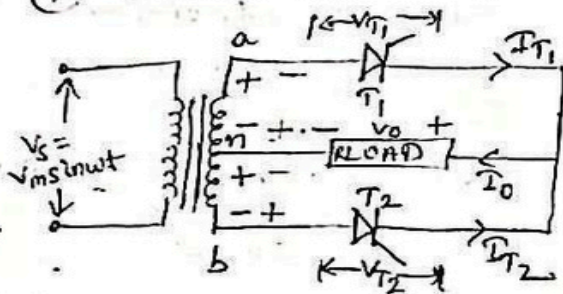

$$V_{an} = V_{nb}$$

$$V_{an} = -V_{on}$$

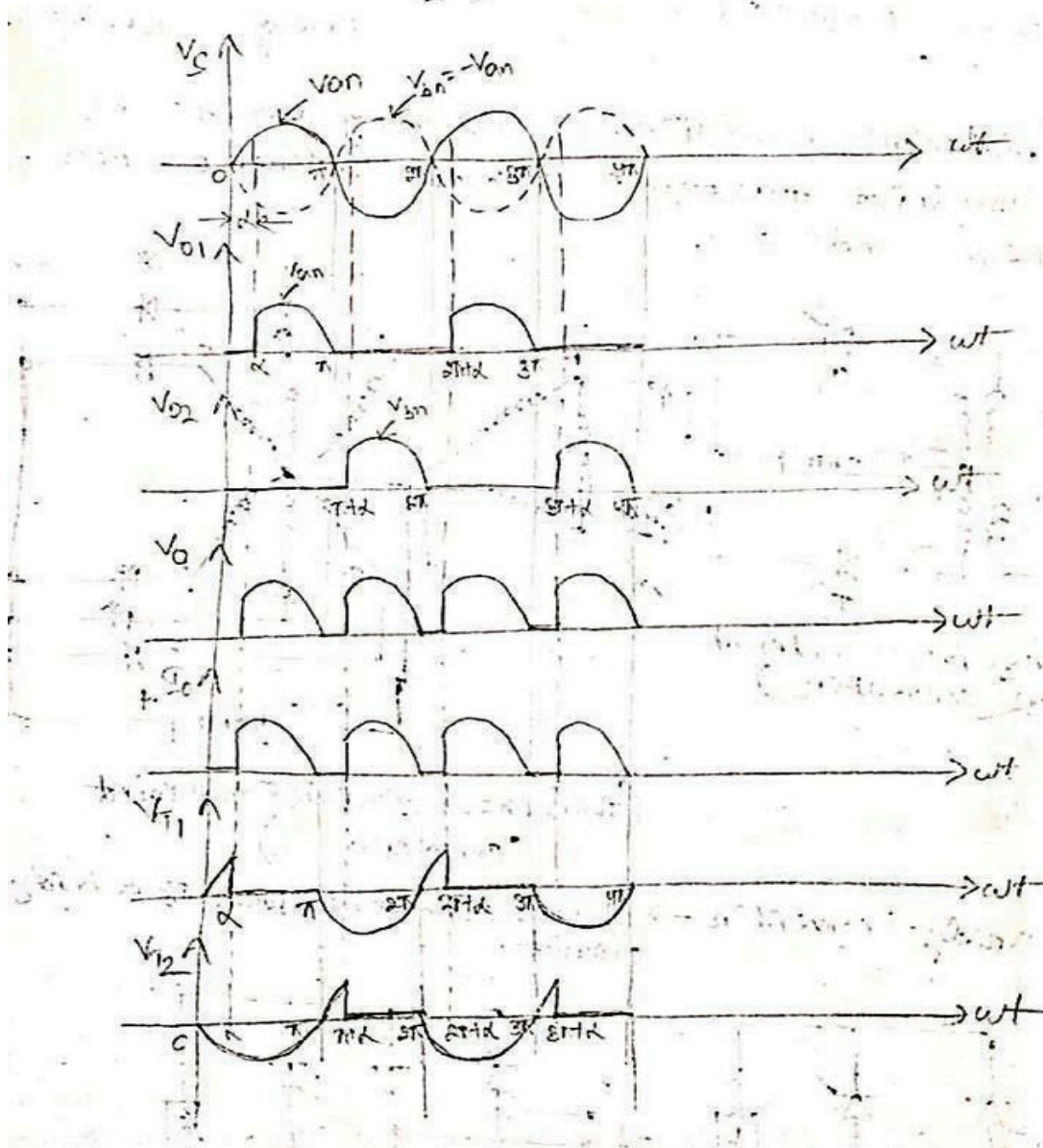

operation \rightarrow

During positive half cycle,

a +ve w.r.t b, V_{an} is in forward path

V_{bn} is in reverse path

anode of T_1 is +ve, cathode is -ve.

At $\omega t = \alpha$, T_1 is turned on

T_2 remains off

$I_o = I_{T1}$, flows in the +ve direction

$V_o = V_{o1}$, forwards in the +ve direction

Hence T_1 is called incoming SCR and

T_2 is outgoing SCR.

During -ve half cycle,

a -ve w.r.t b, V_{an} is in reverse path

V_{bn} is in forward path

anode of T_1 is -ve and cathode is +ve.

$\omega t = \pi$ to $(\pi + \alpha)$, $I_o = 0$, $V_o = 0$

$\omega t = (\pi + \alpha)$, T_1 is OFF and T_2 is ON

$I_o = I_{T2}$ flows in the +ve direction

$V_o = V_{o2}$ forwards in the +ve direction

$$t_c = \frac{\pi}{\omega} \text{ sec.}$$

$$V_o = \frac{1}{2\pi} \int_{\alpha}^{\pi} V_m \sin \omega t \, d\omega t$$

$$V_o = \frac{V_m}{\pi} (1 + \cos \alpha)$$

$$I_o = \frac{V_o}{R} = \frac{V_m}{\pi R} (1 + \cos \alpha)$$

Single Phase Full wave bridge converter →

3 types ① uncontrolled converters:- uses only diodes and the level of dc o/p voltage cannot be controlled.

② half controlled converters:- uses mixture of diodes and thyristors or semi converters

and there is a limited control over the level of dc o/p voltage.

③ A fully controlled converter or full converter :- uses thyristors

only and there is wider control over the level of dc o/p voltage.

Half controlled bridge rectifier with R Load → 1 ϕ bridge type semi converter (R Load)

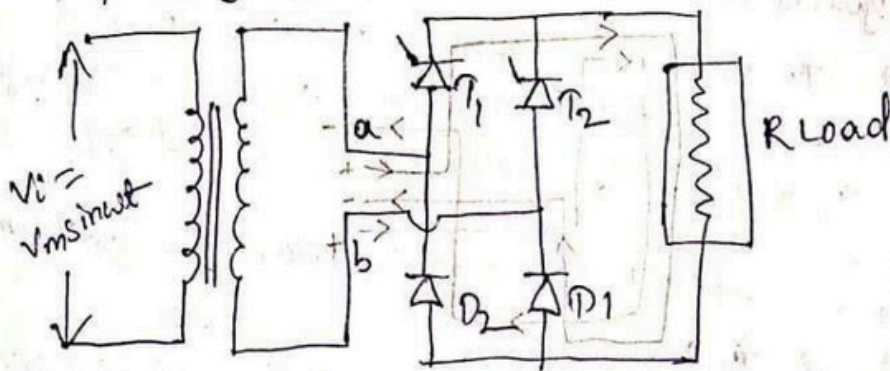

$$V_0 = \frac{V_m}{\pi} (1 + \cos \alpha)$$

$$I_0 = \frac{V_0}{R} = \frac{V_m}{\pi R} (1 + \cos \alpha)$$

During 1st half cycle,

a +ve w.r.t b, T_1, D_1 are forward biased

At $\omega t = \alpha$, T_1 is fired, v_o follows the i/p. Here T_1 is called the incoming SCR and D_1 is called incoming diode. During $\alpha \rightarrow \pi$, T_1, D_1 conducts load current. At $\omega t = \pi$, due to line commutation T_1 stops conducting.

During 2nd half cycle,

a -ve w.r.t b, T_2, D_2 are forward biased

At $\omega t = \pi + \alpha$, T_2 is fired & starts conducting. Here T_1, D_1 are outgoing SCR and diode and T_2, D_2 are incoming SCR and diode respectively. During $(\pi + \alpha) \rightarrow 2\pi$, T_2, D_2 conducts the load current.

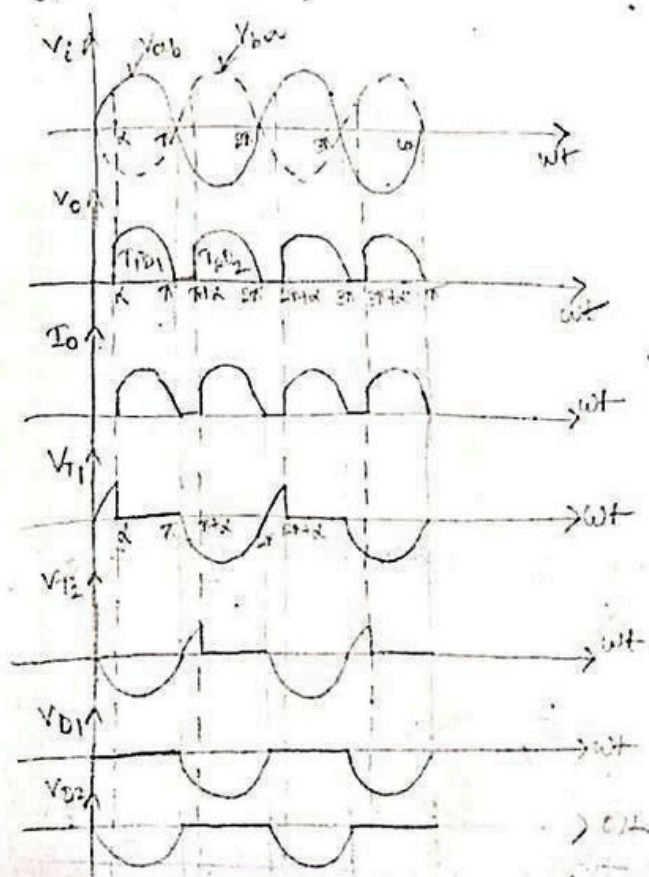

Fully controlled bridge rectifier with R-load →

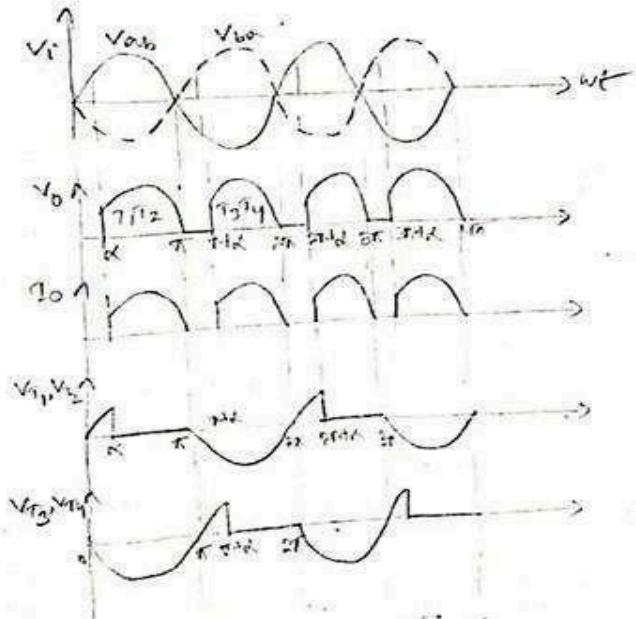
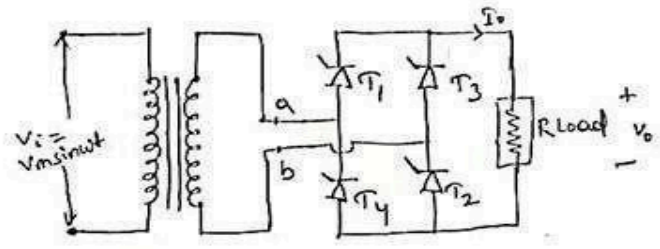

$$V_o = \frac{V_m}{\pi} (1 + \cos \alpha)$$

$$I_o = \frac{V_o}{R} = \frac{V_m}{\pi R} (1 + \cos \alpha)$$

$$t_c = \frac{\pi}{\omega} \text{ sec.}$$

Operation →

During first half cycle, a is +ve w.r.t b. From $\omega t = 0 \rightarrow \alpha$, T_1, T_2 are forward biased but not conduct. $V_o = 0$. At $\omega t = \alpha$, T_1, T_2 are triggered. T_1 and T_2 starts conducting, T_3, T_4 will be off.

1 ϕ full wave bridge converter

(bulky controlled)

R - LOAD

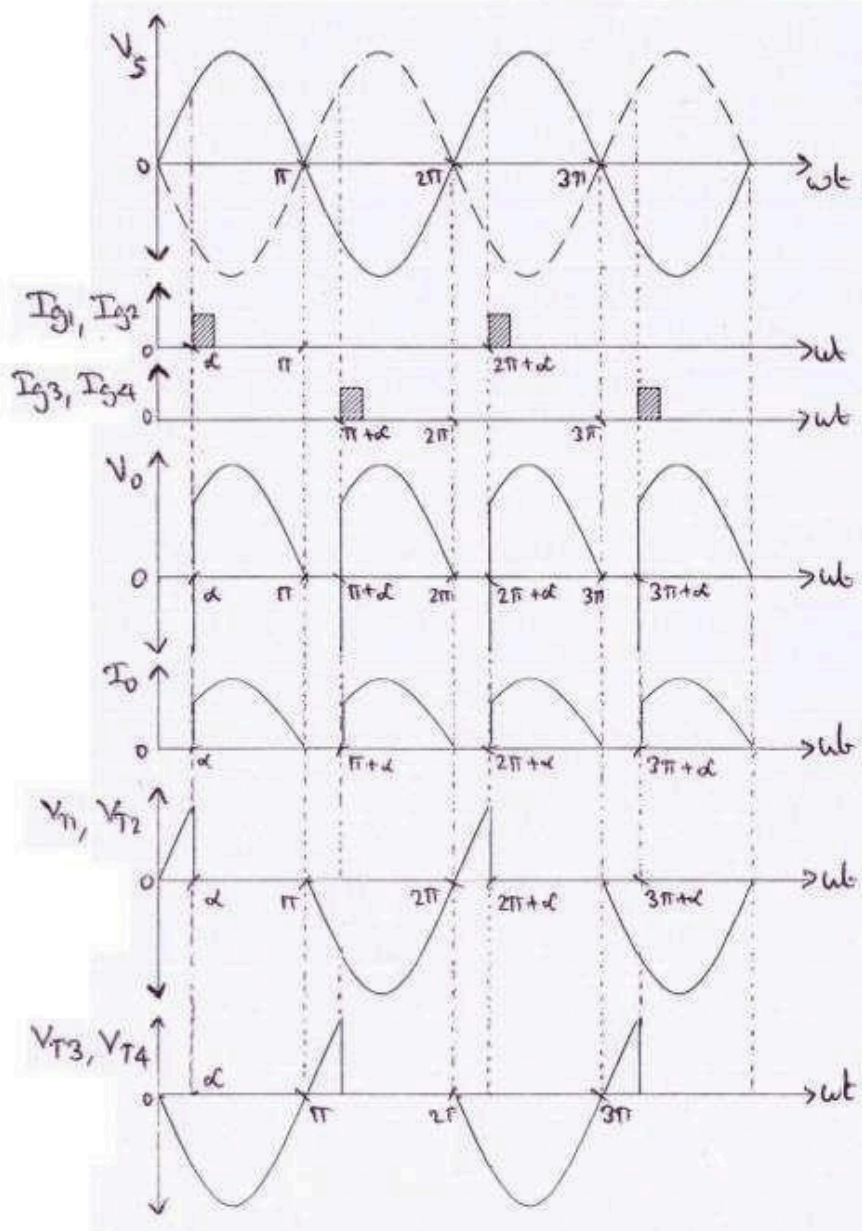
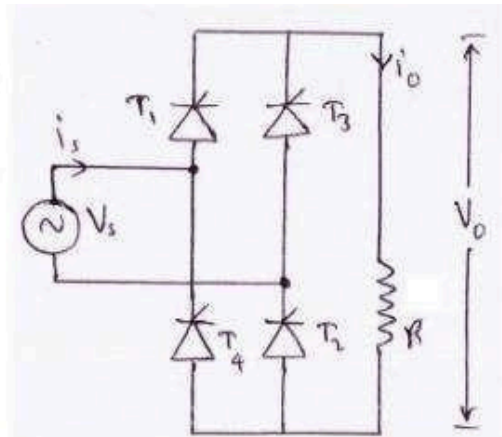

during second half cycle,

b is +ve w.r.t a , T_3, T_4 forward biased but not conducts
 T_1, T_2 stop conducting due to line commutation.

→ Line commutation technique called as natural commutation uses reverse voltage for turning off a thyristor i.e. in this type of rectifier by applying reverse bias across the thyristor and by reducing the anode current level below the holding current level we can turn off the thyristor.

From $\omega t = \pi \rightarrow (\pi + \alpha)$, T_1, T_2 will be off. T_3, T_4 not conduct due to absence of gate signal

From $\omega t = (\pi + \alpha) \rightarrow 2\pi$, T_3 and T_4 are triggered, T_1, T_2 will be off. T_3 and T_4 conduct due to gate signal. In this way the process goes on.

Fully controlled bridge rectifier with RL load →

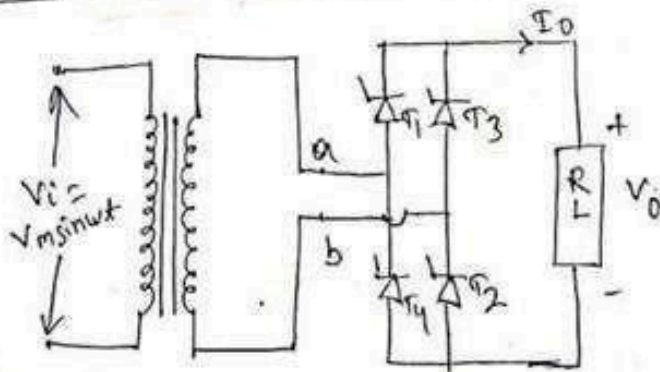

operation →

During first half cycle, a is +ve w.r.t b ,

from $\omega t = 0 \rightarrow \alpha$, T_1 and T_2 are forward biased but not

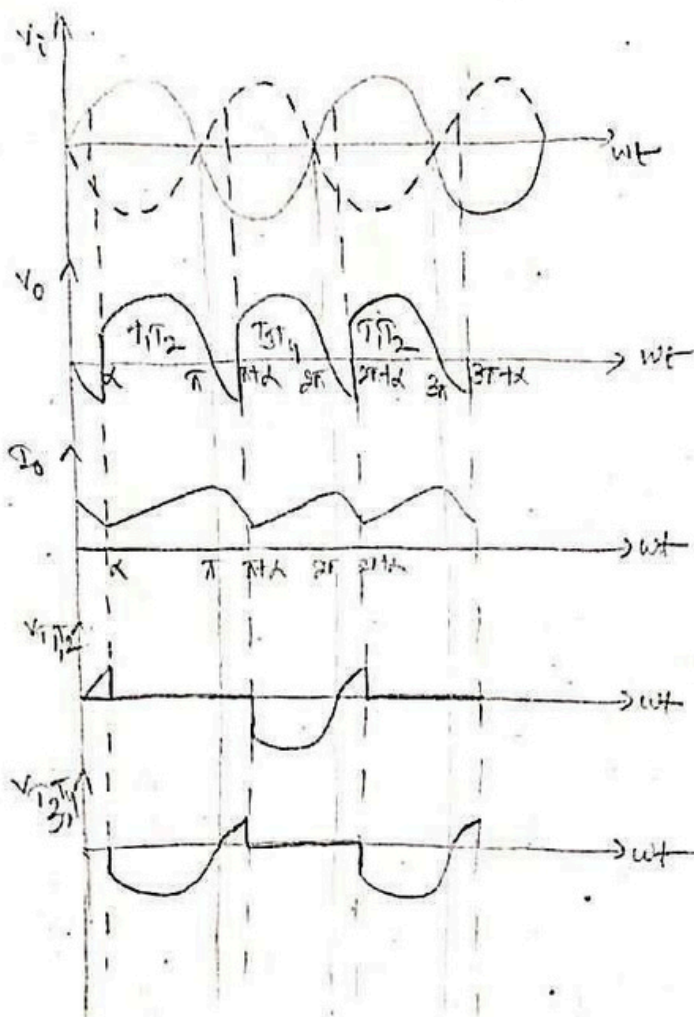

During second half cycle, b +ve w.r.t a,

At $\omega t = \pi \rightarrow (\pi + \alpha)$, v_o follows v_i in reverse path. T_3 and T_4 are forward biased but not conducting. T_1 and T_2 still conduct due to load inductance.

At $\omega t = \pi + \alpha$, T_3 and T_4 are triggered, T_1 and T_2 will be OFF. T_3 and T_4 starts conducting.

From $\omega t = \pi + \alpha \rightarrow 2\pi$, T_3 and T_4 conduct.

During second first half cycle, a +ve w.r.t b,

$\omega t = 2\pi \rightarrow (2\pi + \alpha)$, T_3 and T_4 still conduct due to load inductance and here v_o follows v_i in reverse path.

At $\omega t = (2\pi k) \rightarrow 3\pi$, again T_1 and T_2 are triggered and T_3 and T_4 conduct due to gate signal. Here T_3 and T_4 will be off, and the process continues.

$$V_0 = \frac{2V_m}{\pi} \cos \alpha$$

$$I_0 = \frac{V_0}{R} = \frac{2V_m}{\pi R} \cos \alpha$$

$$t_c = \frac{\pi - \alpha}{\omega} \text{ sec.}$$

Fully controlled bridge rectifier with RL and flywheel diode \rightarrow

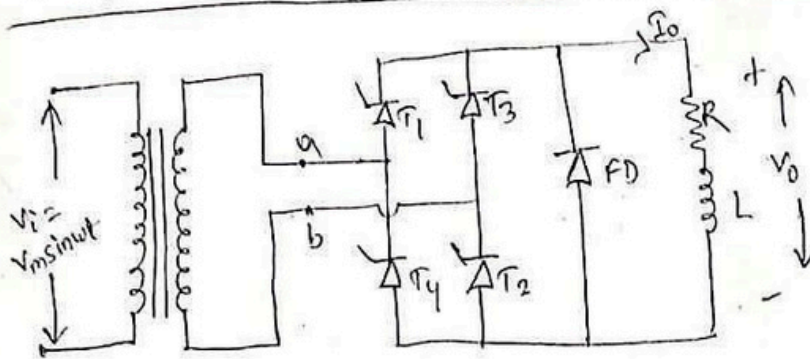

$$V_0 = \frac{V_m}{\pi} (1 + \cos \alpha)$$

$$I_0 = \frac{V_m}{\pi R} (1 + \cos \alpha)$$

$$t_c = \frac{\pi}{\omega} \text{ sec.}$$

operation \rightarrow

V_i = i/p voltage

V_0 = o/p voltage

I_0 = current flowing through load

$V_{T1}, V_{T2}, V_{T3}, V_{T4}$ are voltages across thyristors T_1, T_2, T_3, T_4 .

FD flywheel diode.

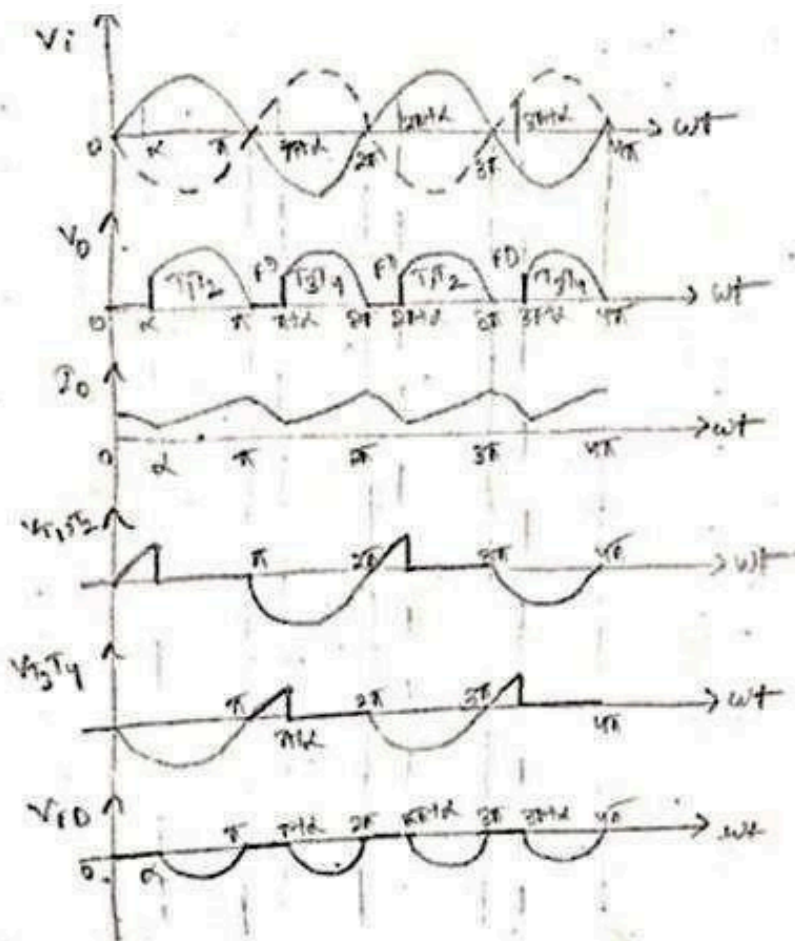

operation →

The operation of 1st fully controlled bridge rectifier with RL load and FD is similar to that of half controlled bridge rectifier feeding RL load with FD.

$\omega t = 0 \rightarrow \alpha$ $V_o = 0$, I_o falls from its peak value, $V_{FD} = 0$

$\omega t = \alpha \rightarrow \pi$ V_o follows V_i in the forward path, I_o rises towards the peak. V_{FD} follows V_i in reverse path.

$\omega t = \pi \rightarrow \pi+\alpha$ $V_o = 0$, I_o falls from its peak value. $V_{FD} = 0$

$\omega t = \pi+\alpha \rightarrow 2\pi$ V_o follows V_i in forward path, I_o rises towards the peak. V_{FD} follows V_i in reverse path.

now $\omega t = 2\pi \rightarrow (2\pi+\alpha)$ and

$\omega t = (2\pi+\alpha) \rightarrow 3\pi$ the process continues.

Three phase half wave Controlled Converter with resistive load

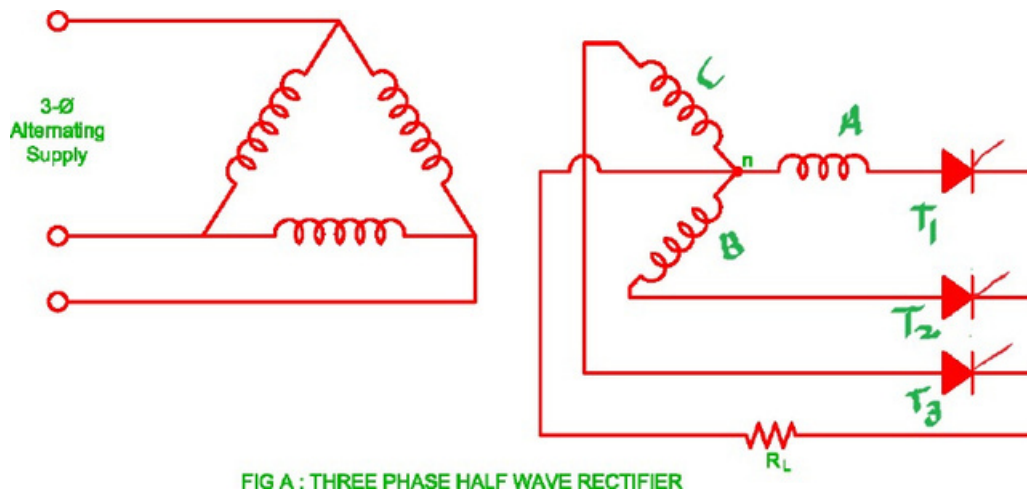

For a 3 - phase half-wave controlled rectifier shown in Fig. A, the input phase voltages V_a , V_b , V_c have same amplitude and frequency with 120° phase shift as shown in Fig.2.

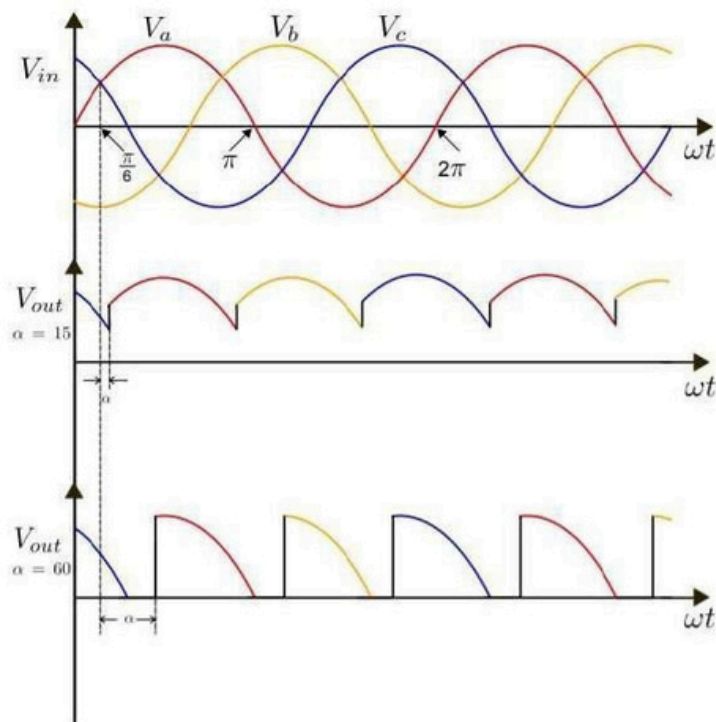

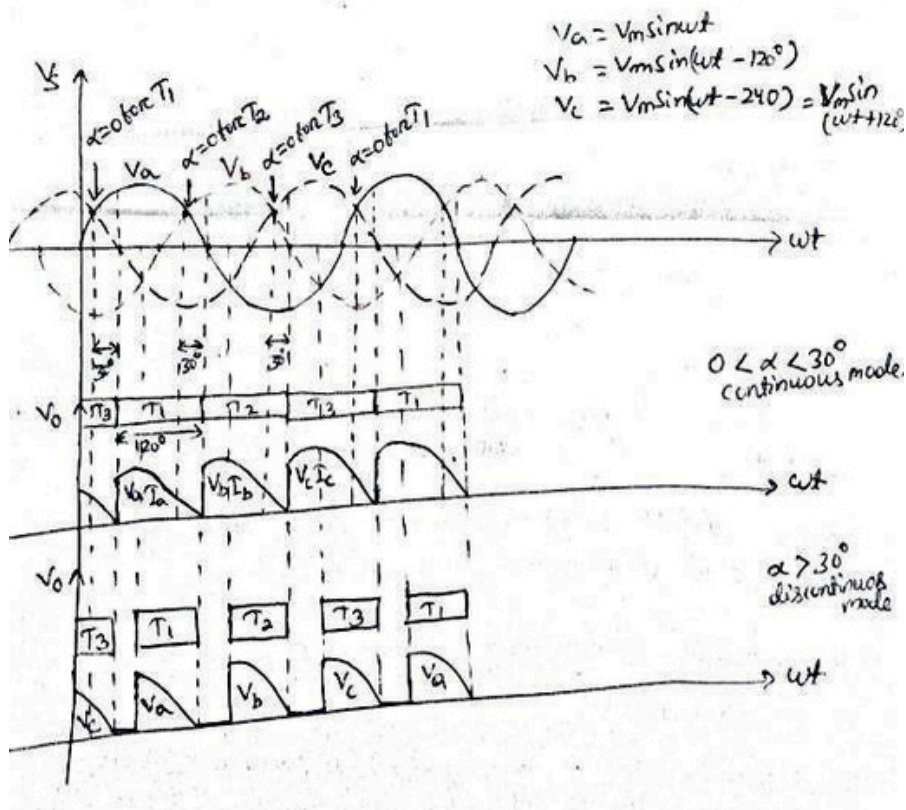
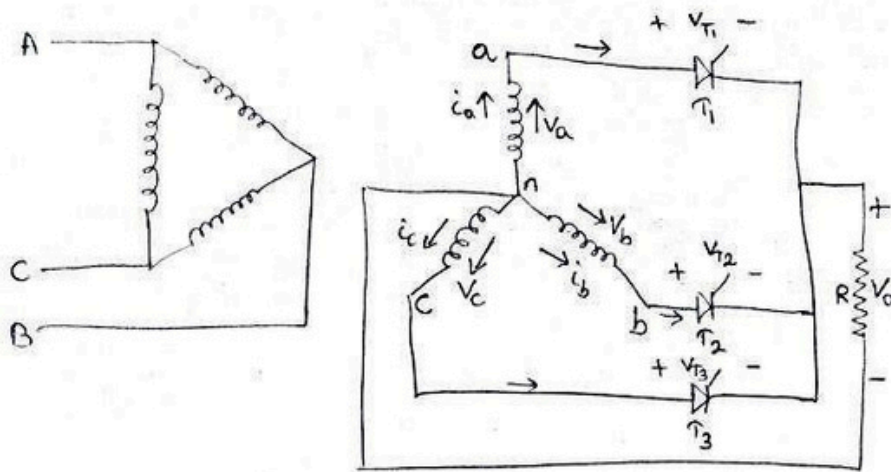

This converter is called 3-phase 3-pulse converter or 3-phase M-3 converter.

With reference to the above circuit diagram and waveforms, if firing angle is zero-degree, SCR T1 would begin conducting from $\omega t = 300$ to 1500 , T2 from $\omega t = 1500$ to 2700 and T3 from $\omega t = 2700$ to 3900 and so on. In other words, firing angle for this controlled converter would be measured from $\omega t = 300$ for T1, from $\omega t = 1500$ for T2 and from $\omega t = 2700$ for T3. For zero degree firing

angle delay thyristor behaves as a diode. The operation of this converter is now described for $\alpha < 300$ and for $\alpha > 300$.

Firing angle < 300 ,

The output voltage waveform for firing angle less than 300 (say around 300) is sketched, where T1 conducts from $\omega t = 300 + \alpha$ to $\omega t = 1500 + \alpha$, T2 conducts from $\omega t = 1500 + \alpha$ to

$\omega t = 2700 + \alpha$, T3 conducts from $\omega t = 2700 + \alpha$ to $\omega t = 3900$

+ α and so on. Each SCR conducts for 120 degrees. The waveform of load

current would be identical with voltage

waveform. Average value of output

voltage

$$V_0 = \frac{3\sqrt{3}}{3\pi} V_{mp} \cos \alpha$$

$$V_0 = \frac{2}{2\pi} V_{ml} \cos \alpha$$

Where V_{mp} = maximum value of phase voltage

V_{ml} = maximum value of line voltage = $\sqrt{3} V_{mp}$

α = firing angle

$$I_0 = \frac{V_0}{R} = \frac{3}{2\pi R} V_{ml} \cos \alpha$$

Firing angle > 300 ,

When firing angle is more than 300, T1 conducts from $\omega t = 300 + \alpha$ to $\omega t = 1800$, T2 conducts from $\omega t = 1500 + \alpha$ to $\omega t = 3000$, T3 conducts from $\omega t = 2700 + \alpha$ to $\omega t = 4200$ and so

on. For R load when phase voltage V_0 reaches zero at

$\omega t = 300 + \alpha$ to $\omega t = 1800$. Same is true for other SCRs. This shows that each SCR for Firing angle > 300 conducts for $(1500 - \alpha)$ only. This also implies that for R load maximum possible value of firing angle is 1500. The waveform of load current would be identical with voltage waveform.

Average value of output voltage

$$V_0 = \frac{3}{2\pi} V_{mp} [1 + \cos(\alpha + 300)]$$

Where v_{mp} = maximum value of phase voltage

$\alpha =$ firing angle

Three phase fully Controlled Converter with resistive load

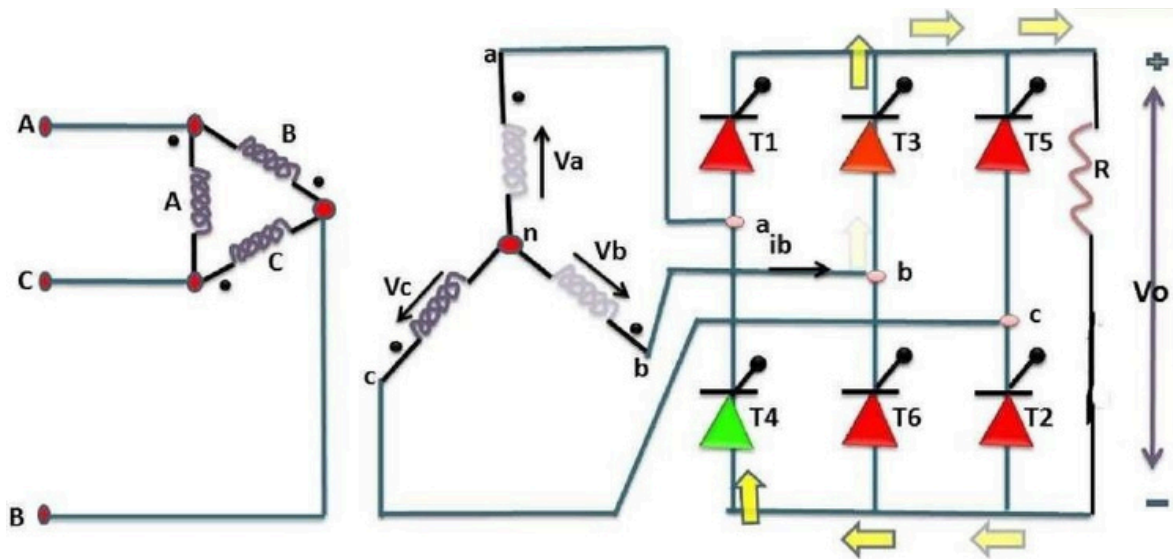

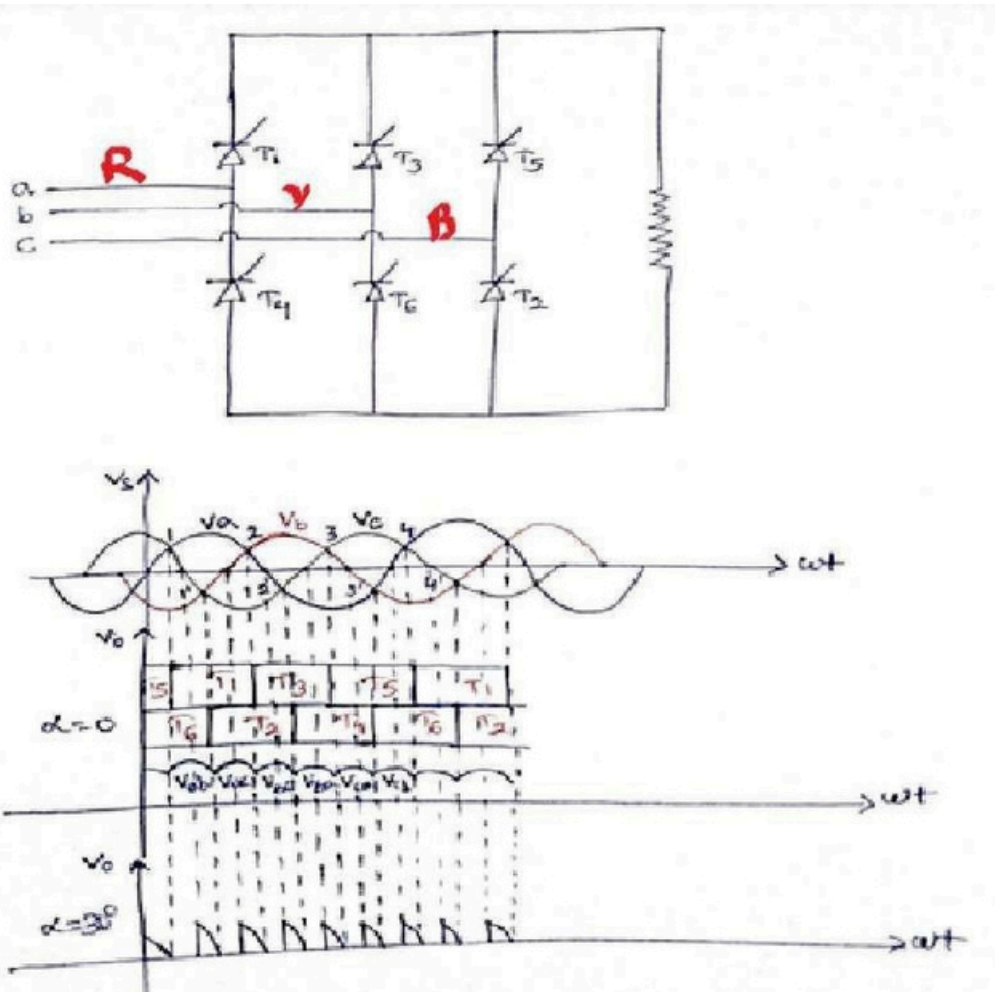

(3-phase 6-pulse)

The three-phase bridge rectifier circuit has three-legs, each phase of the three phase voltages.

Alternatively, it can be seen that the bridge circuit has two halves, the positive half consisting of the SCRs S1, S3 and S5 and the negative half consisting of the SCRs S2, S4 and S6. At any time when there is current flow, one SCR from each half conducts. If the phase sequence of the source be RYB, the SCRs are triggered in the sequence S1, S2, S3, S4, S5, S6 and S1 and so on.

The operation of the circuit is first explained with the assumption that diodes are used in place of the SCRs. The three-phase voltages vary as shown below.

Let the three-phase voltages be defined as shown below.

$$v_R(\theta) = E * \sin(\theta), \quad v_Y(\theta) = E * \sin(\theta - 120^\circ), \quad \text{and} \quad v_B(\theta) = E * \sin(\theta + 120^\circ).$$

It can be seen that the R-phase voltage is the highest of the three-phase voltages when ωt is in the range from 30° to 150° . It can also be seen that Y-phase voltage is the highest of the three-phase voltages when ωt is in the range from 150° to 270° and that B-phase voltage is the highest of the three-phase voltages when ωt is in the range from 270° to 390° or 30° in the next cycle. We also find that R-phase voltage is the lowest of the three-phase voltages when ωt is in the range from 210° to 330° . It can also be seen that Y-phase voltage is the lowest of the three-phase voltages when ωt is in the range from 330° to 450° or 90° in the next cycle, and that B-phase voltage is the lowest when ωt is in the range from 90° to 210° . If diodes are used, diode D1 in place of S1 would conduct from 30° to 150° , diode D3 would conduct from 150° to 270° and diode D5 from 270° to 390° or 30° in the next cycle. In the same way, diode D4 would conduct from 210° to 330° , diode D6 from 330° to 450° or 90° in the next cycle, and diode D2 would conduct from 90° to 210° . The positive rail of output voltage of the bridge is connected to the topmost segments of the envelope of three-phase voltages and the negative rail of the output voltage to the lowest segments of the envelope.

Period, range of ωt	SCR Pair in conduction
30° to 90°	S1 and S6
90° to 150°	S1 and S2
150° to 210°	S2 and S3
210° to 270°	S3 and S4
270° to 330°	S4 and S5
330° to 360° and 0° to 30°	S5 and S6

If SCRs are used, their conduction can be delayed by choosing

the desired firing angle. When the SCRs are fired at 0° firing angle, the output of the bridge rectifier would be the same as that of the circuit with diodes. For instance, it is seen that D1 starts conducting only after $\alpha = 30^\circ$. In conducting only after $\alpha = 30^\circ$, since it is reverse-biased before $\alpha = 30^\circ$. across D1 becomes zero when $\alpha = 30^\circ$ and diode D1 starts getting forward-biased only after $\alpha = 30^\circ$. When $v_R(\alpha) = E \sin$
The bias
 30° and it is forward-biased
when $\alpha > 30^\circ$. When firing angle to SCRs is zero degree, S1 is 30° . This means that if a synchronizing signal is needed for signal voltage would lag $v_R(\alpha)$ by 30° and if the firing

triggered when $q = a + 30^\circ$. Given that the conduction is continuous, the following table presents the SCR pair in conduction at any instant.

Period, range of q	SCR Pair in conduction
$a + 30^\circ$ to $a + 90^\circ$	S1 and S6
$a + 90^\circ$ to $a + 150^\circ$	S1 and S2
$a + 150^\circ$ to $a + 210^\circ$	S2 and S3
$a + 210^\circ$ to $a + 270^\circ$	S3 and S4
$a + 270^\circ$ to $a + 330^\circ$	S4 and S5
$a + 330^\circ$ to $a + 360^\circ$ and $a + 0^\circ$ to $a + 30^\circ$	S5 and S6

SINGLE PHASE AC REGULATOR OR CONTROLLER – PHASE ANGLE CONTROL

- AC voltage controllers are thyristor based devices which convert fixed alternating voltage directly to variable alternating voltage without change in frequency.
- Using these controllers, rms value of the voltage across the load is steplessly varied from a maximum value to zero.
- The simplest way to control AC voltage to the load is by using AC switch (bidirectional).
- The bi-directional conducting property can be achieved by simply connecting two unidirectional thyristors in inverse parallel to each other.



- AC voltage controllers are naturally commutated

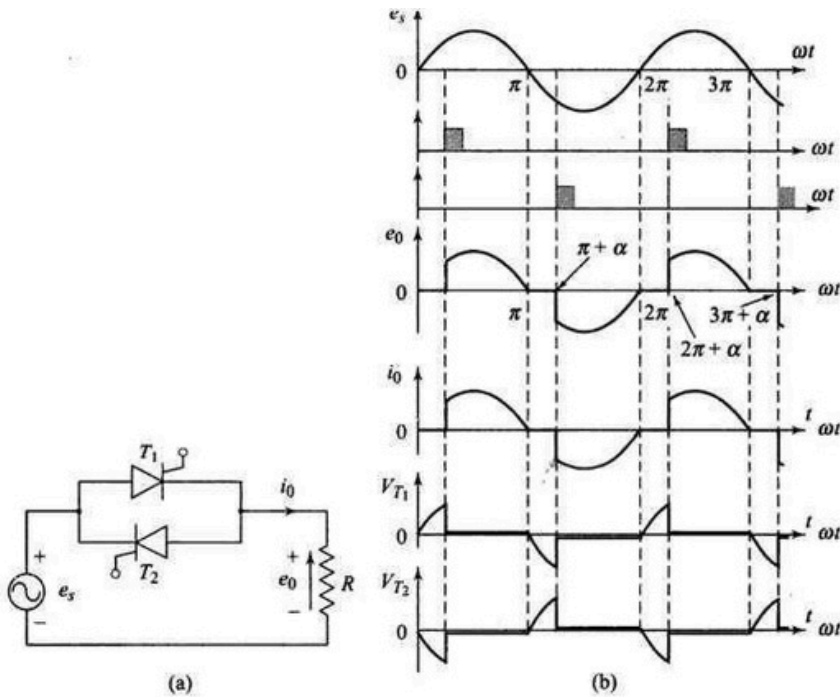

Fig.1 (a) Single-phase a.c. voltage controller with R load (b) voltage and current waveforms

Thyristors T1 and T2 are forward biased during positive and negative half-cycle, respectively. During positive half-cycle, T1 is triggered at a firing angle α . T1 starts conducting and source voltage is applied to load. At π , both e_0 and i_0 fall to zero. T1 is subjected to reverse bias and it is, therefore, turned-off. During negative half-cycle T2 is triggered at $(\pi + \alpha)$. T2 conducts from $(\pi + \alpha)$ to 2π . Soon after 2π , T2 is subjected to a reverse bias and it is, therefore, commutated. Load and source currents have the same waveform. From zero to

α , T1 is forward biased, therefore $V_{T1} = e_s$ as shown in Fig.1.b. From α to π , T1 conducts, V_{T1} is therefore about V_T . After π , T1 is reverse biased by source voltage, therefore, $V_{T1} = -e_s$ from π to $(\pi + \alpha)$. The voltage variation V_{T1} across T1 is shown in Fig.1.b. Similarly, the variation of voltage V_{T2} across thyristor T2 can be drawn. In Fig.1.b, voltage drop across thyristors T1 and T2 is purposely shown just to highlight the duration of reverse bias across T1 and T2.

Examination of this figure reveals that for any value of α , each thyristor is reverse biased for π / ω seconds.

SINGLE PHASE AC REGULATOR OR CONTROLLER – INTEGRAL CYCLE CONTROL

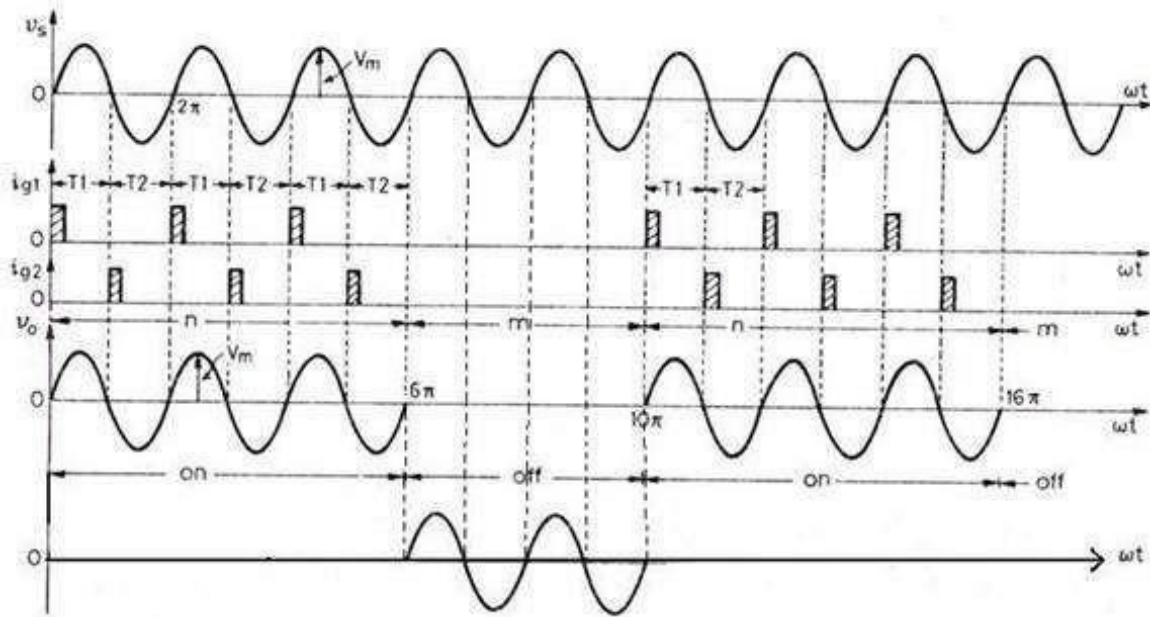

1- On-Off Control (Integral Cycle Control)

The load power can be controlled by connecting the source to the load for few complete cycles then disconnecting the source from the load for another number of cycles, and repeating the switching cycle.

Suitable for systems with large time constants.

Average power to the load can be varied from 0% through 100%

Integral cycle control finds applications in heating loads and for motor speed control.

STEP UP & STEP-DOWN

CHOPPER STEP DOWN

CHOPPER

A chopper is a static device that converts fixed DC input voltage to variable output voltage directly. Choppers are mostly used in electric vehicles, mini haulers. Choppers are used for speed control and braking. The systems employing choppers offer smooth control, high efficiency and have fast response.

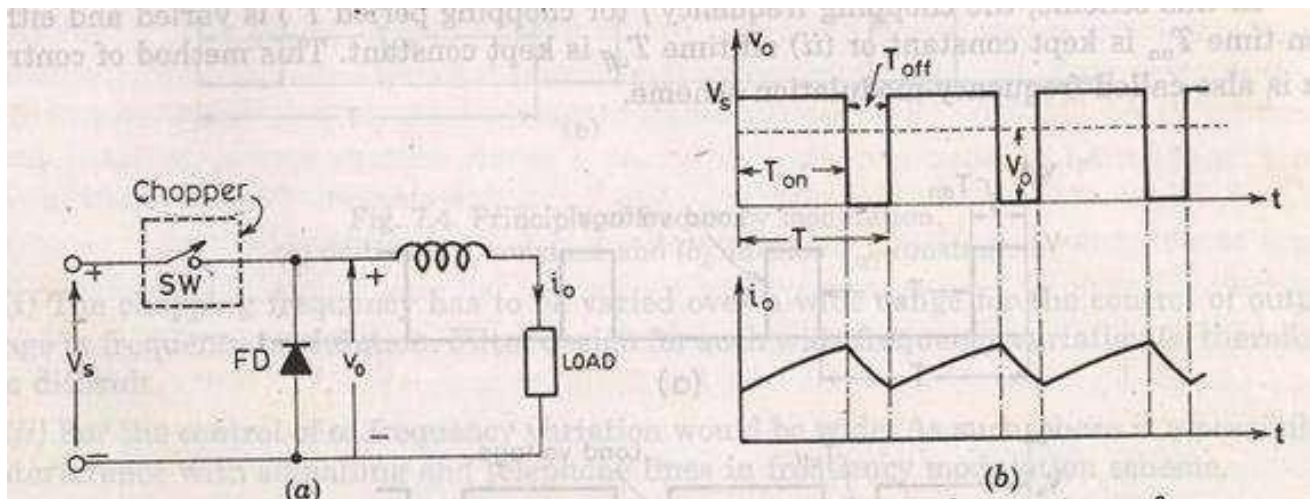

- Chopper is a static device that converts fixed dc i/p voltage to a variable dc o/p voltage directly.
- Chopper is a high speed on-off semiconductor switch that converts fixed dc input voltage to a variable dc o/p voltage by connecting source to load and disconnecting the load from source at a fast speed.

Application

- subway cars
- trolley buses, trolley cars
- battery operated vehicles
- battery charging
- marine hoists
- forklift trucks
- mine haulers
- Electric automobiles speed control & braking

AC link chopper

Here first dc is converted to ac by inverter. Ac is then stepped up or ^{stepped} down by a transformer which is then converted back to dc by a diode rectifier. Here conversion is in two stages (dc \rightarrow ac & ac \rightarrow dc) so this chopper is costly & less efficient.

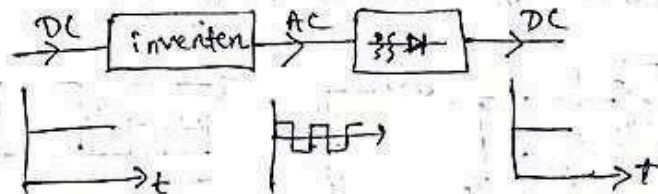

DC chopper

A chopper is a static device that converts fixed dc i/p voltage to variable dc o/p voltage directly.



Chopper represented by

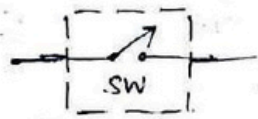

or

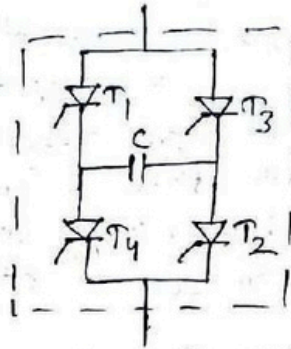

Chopper can be represented by a switch SW with an arrow. When the switch is off no current can flow. When the switch is on current flows in the direction of arrow only.

- Chopper is dc equivalent of an ac transformer having continuously variable turns ratio. Like a transformer chopper can be used to step down or step up the fixed dc input voltage.

Principle of Chopper operation →

A Chopper is a high speed ON/OFF semiconductor switch. It connects source to load and disconnects the load from the source at a fast speed. In this manner a chopped load voltage is obtained from a constant dc supply of magnitude V_s . Chopper is represented by a switch SW inside a dotted rectangle, which may be turned on or turned off as desired.

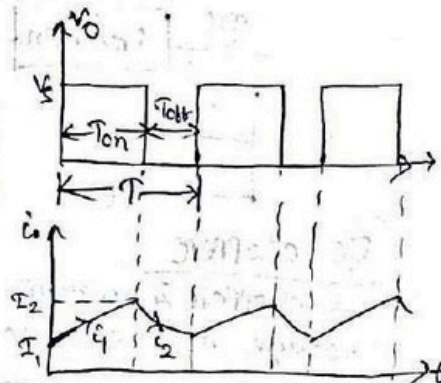
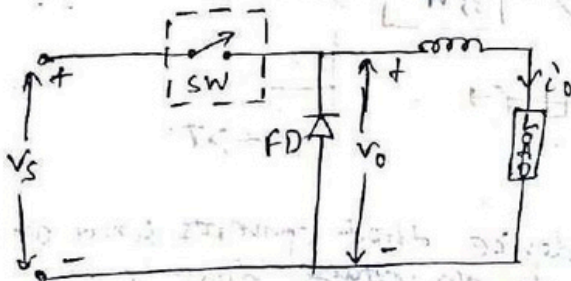

During the period T_{on} , chopper is on and load voltage is equal to source voltage V_s . During the interval T_{off} , chopper is off, load current flows through the FD, so that load terminals are short circuited by FD and load voltage is zero during T_{off} . In this manner, chopped dc voltage is produced at the load terminals. The load current is continuous.

$$\text{Average load voltage, } V_0 = \frac{T_{on}}{T_{on} + T_{off}} V_s$$

$$V_0 = \frac{T_{on}}{T} V_s$$

$$V_0 = \alpha \cdot V_s$$

T_{on} = on time

T_{off} = off time

$T = T_{on} + T_{off}$ = Chopping period

$\alpha = \frac{T_{on}}{T}$ = duty cycle

- Hence the load voltage can be controlled by varying duty cycle α .
- load voltage is independent of load current.

$$V_0 = f \cdot T_{on} \cdot V_s$$

$$f = \frac{1}{T} = \text{chopping frequency.}$$

equivalent ckt \rightarrow

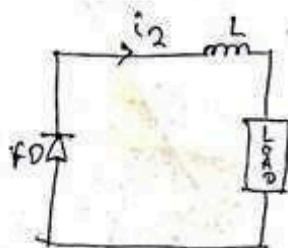
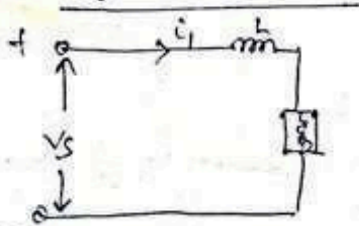

2.8.2 STEP UP CHOPPER

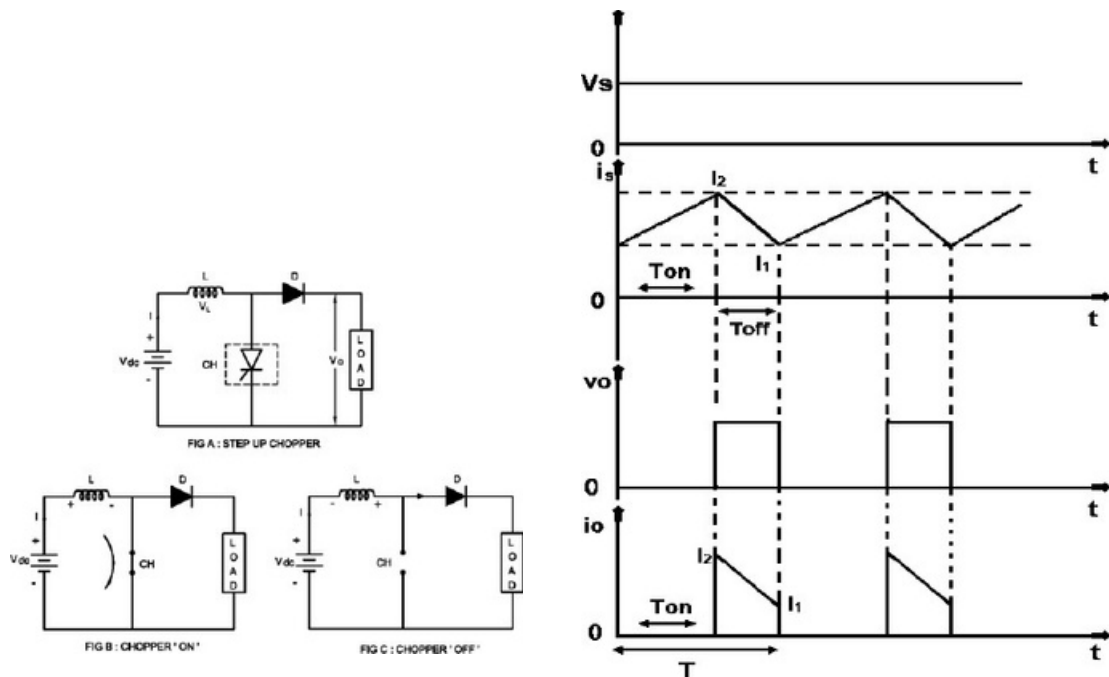

Working of Step up Chopper

The step up chopper is one in which output DC voltage is greater than the input DC voltage.

The basic diagram for the step up chopper is shown in the figure A.

When the chopper is switched ON during T_{ON} time, the energy stored in the inductor via path $V_{dc} - L - CH - V_{dc}$.

The direction of current passing through inductor is shown in the figure B when the chopper CH is switched on.

When chopper is switched OFF during T_{OFF} time, the current passing through inductor is zero and voltage across inductor is $L (di/dt)$.

The stored energy of inductor is transferred to the load.

The circuit diagram of step up chopper during chopper OFF time is shown in the figure C.

The load / output voltage is

equal to $V_O = V_{dc} + V_L$

$$= V_{dc} + L (di/dt)$$

When chopper is switch ON, the energy stored in

$$\text{the inductor is } W_i = V_{dc} I T_{ON} \quad (1)$$

When chopper is switched OFF, the energy stored in the inductor is transferred to the load.

$$V_o = (V_o - V_{dc}) I_{TOFF} \cdot T$$

If there are no losses in the system, the input energy is equal to output energy $V_{dc} I_{TON} = (V_o - V_{dc}) I_{TOFF}$

$$V_{dc} T_{ON} = V_o T_{OFF} - V_{dc} T_{OFF}$$

$$V_{dc} (T_{ON} + T_{OFF}) = V_o T_{OFF}$$

$$V_o = \left[\frac{T_{ON} + T_{OFF}}{T_{OFF}} \right] V_{dc}$$

$$V_o = \left[\frac{T}{T_{OFF}} \right] V_{dc}$$

V_{dc}

OR

$$V_o = \left[\frac{T}{T - T_{ON}} \right] V_{dc}$$

$$V_o = \left[\frac{1}{1 - T_{ON}/T} \right] V_{dc}$$

$$V_o = \left[\frac{1}{1 - K} \right] V_{dc}$$

When $K = 0$ (chopper is in OFF condition)

$V_o = V_{dc}$ When $K = 1$ (chopper is in OFF condition) $V_o = \infty$

When the duty cycle lies in the range of $0 < K < 1$, the output voltage lies in the range of $V_{dc} < V_o < \infty$.

Application of DC Step up Chopper

The application of step up chopper is in the regenerative braking of DC Motor. The output voltage is greater than the input voltage therefore the DC

Constant frequency operation:

1) The chopping period T is kept constant and on time is varied. The pulse width modulation, the width of the pulse is varied.

2) Variable frequency operation, the chopping frequency f is varied. Frequency modulation, either on time or off time is kept constant.

This type of control generate harmonics at unpredictable frequency and filter design is often difficult.

Control strategies →

$$\boxed{\text{avg } V_o = \alpha \cdot V_s}$$

$$V_o = \frac{T_{on}}{T} \cdot V_s$$

$$V_o = f \cdot T_{on} \cdot V_s$$

The average o/p voltage V_o can be controlled through α by opening and closing the semiconductor switch periodically.

various control strategies of varying duty cycle α :->

① constant frequency system / PWM / TRC system

- ontime T_{on} is varied
- chopping frequency f or chopping period T is constant.
- variation of T_{on} means adjustment of pulsewidth.
- Also known as pulse width modulation or time ratio control system.

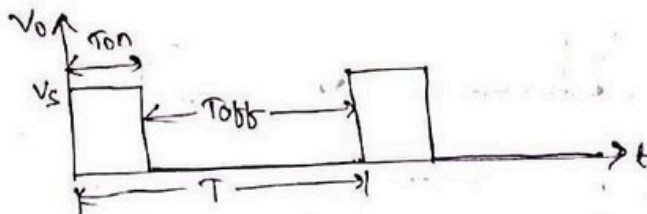

$$T_{on} = \frac{1}{4} T$$
$$\alpha = 0.25 \text{ or } 25\%$$

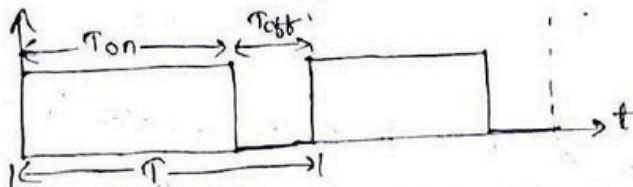

$$T_{on} = \frac{3}{4} T$$
$$\alpha = 0.75 \text{ or } 75\%$$

Limitation → In PWM technique, T_{on} cannot be reduced to near zero for most of the commutation circuits used in choppers, so that low range of α control is not possible in PWM. This can be achieved by increasing the chopping period or decreasing the chopping frequency.

② variable frequency system / frequency modulation

- chopping frequency \neq one chopping period T is varied and either τ_{on} is constant or τ_{off} is constant.
- Also called as frequency modulation scheme.

(a) τ_{on} kept constant, T varied

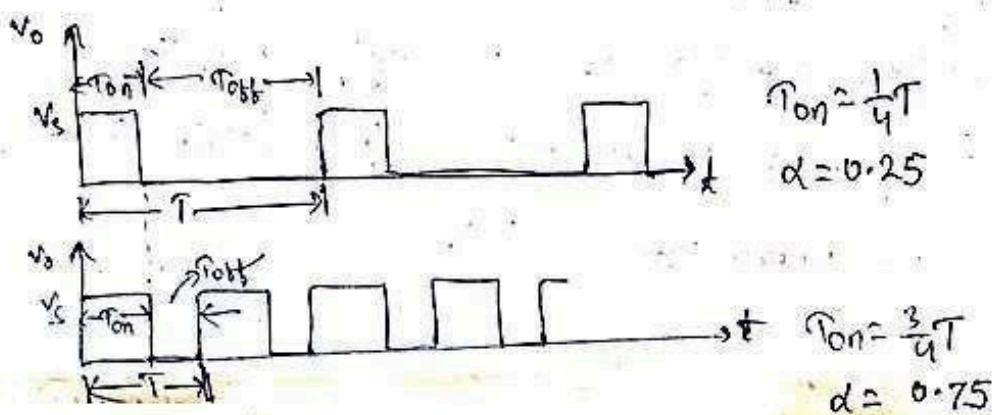

(b) τ_{off} is kept constant and T varied

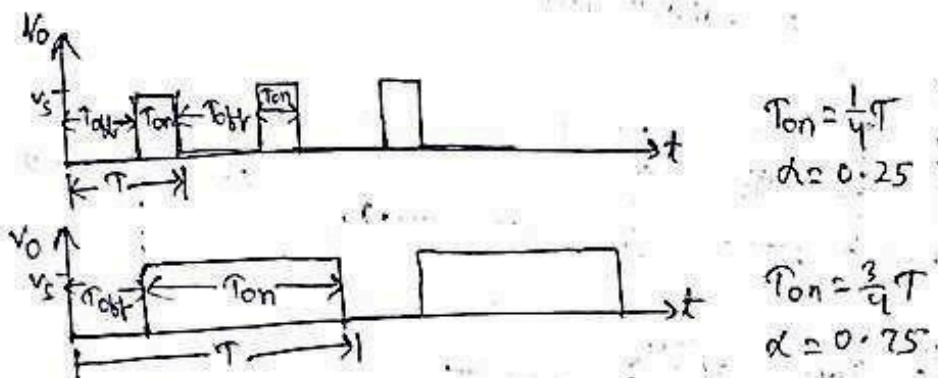

disadvantages \rightarrow

- \rightarrow filter design for wide frequency variation is difficult.
- \rightarrow possibility of interference with signalling and telephone lines.
- \rightarrow large off-time may make the load current discontinuous.

TYPES OF CHOPPER:

FIRST QUADRANT OR TYPE A CHOPPER:

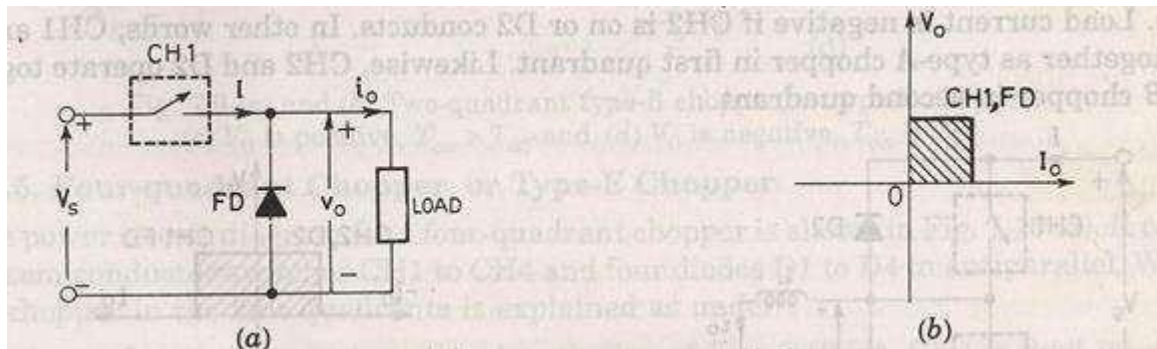

When switch ON

$$V_o = V_s$$

Current i_o flows in the same direction when switch off.

$$V_o = 0, i_o = 0$$

So, average value of both the load and the current are positive.

SECOND QUADRANT OR TYPE B CHOPPER:

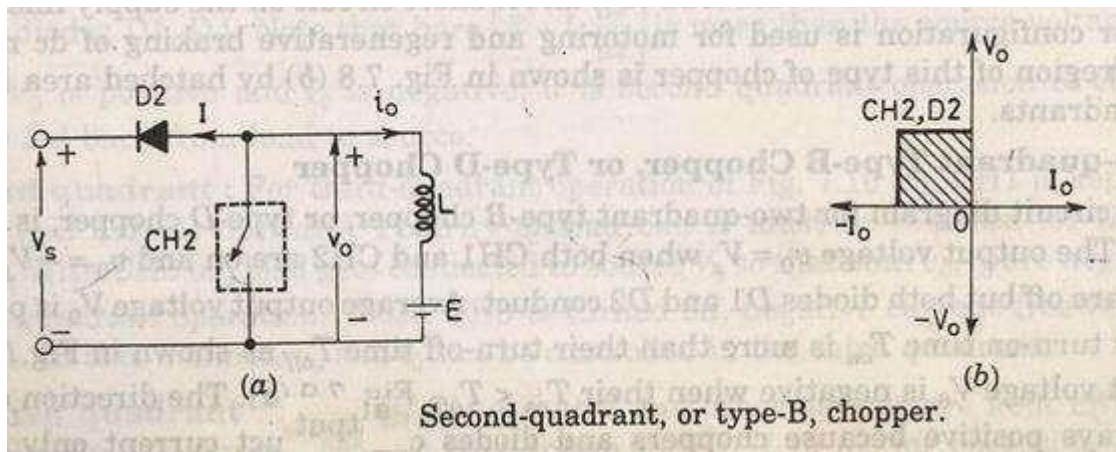

When switch is closed the load voltage E drives current through L and switch. During T_{on} , L stores energy.

When switch off V_o exceeds source voltage V_s .

$$V_o = E + L \frac{di}{dt}$$

Diode D_2 is forward biased. power is fed back to supply. As V_o is more than

source voltage. So such chopper is called step up chopper. So current is always negative and

V_o is always positive.

TWO QUADRANT TYPE A CHOPPER OR, TYPE C CHOPPER:

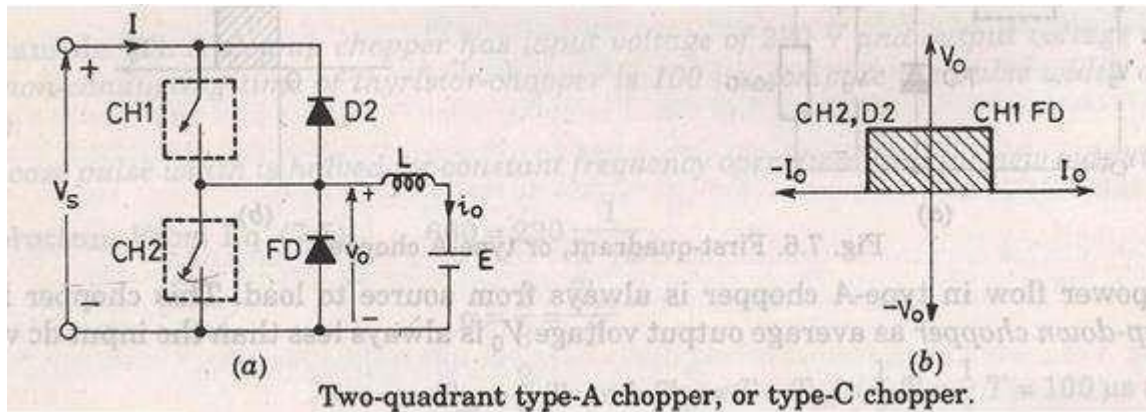

Both the switches never switch ON simultaneously as it lead direct short circuit of the supply.

Now when sw2 is closed or FD is on the output voltage V_o is zero.

When sw1 is ON or diode D conducts output voltage is V_o is $+V_s'$

CURRENT ANALYSIS:

When CH1 is ON current flows along i_o . When CH1 is off current continues to flow along i_o as FD is forward biased. So i_o is positive.

Now when CH2 is ON current direction will be opposite to i_o . When sw2 is off D2 turns ON. Load current is $-i_o$. So average load voltage is always positive.

Average load current may be positive or negative.

TWO QUADRANT TYPE B CHOPPER, OR TYPE D CHOPPER:

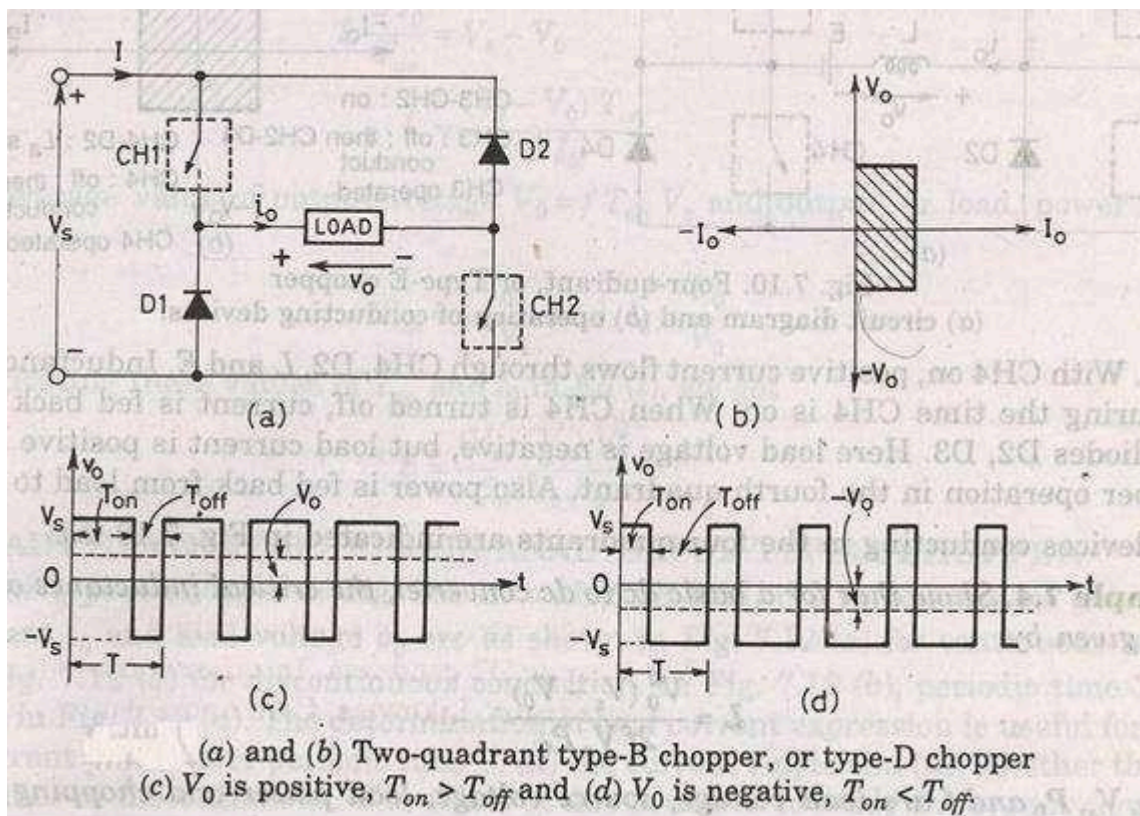

When CH1 and CH2 both are on then $V_0 = V_s$.

When CH1 and CH2 are off and D1 and D2 are on $V_0 = -V_s$.

The direction of current is always positive because chopper and diode can only conduct in the direction of arrow shown in fig. Average voltage is positive when $T_{on} > T_{off}$

FOUR QUADRANT CHOPPER, OR TYPE E CHOPPER

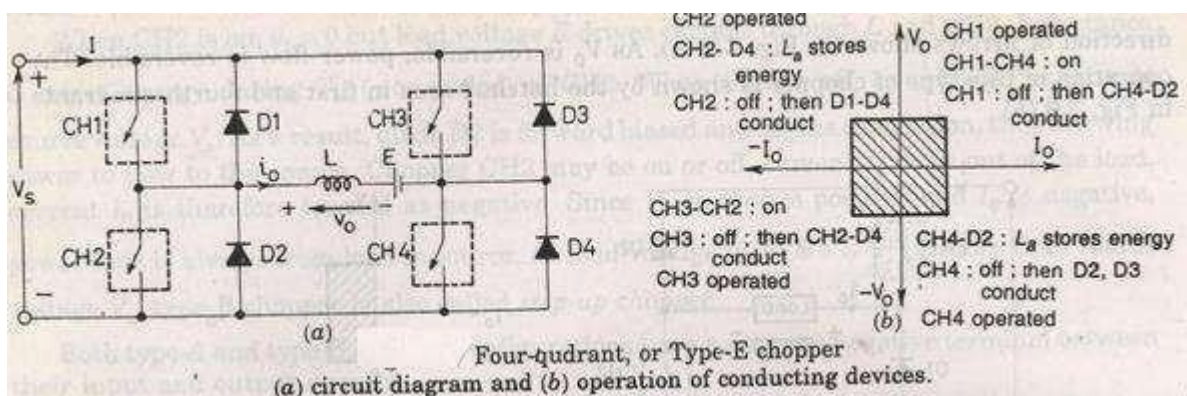

FIRST QUADRANT:

CH4 is kept

ON CH3 is off

CH1 is operated

$V_0 = V_s$

$i_0 = \text{positive}$

when CH1 is off positive current free wheels through CH4, D2 so V_0 and I_2 is in first quadrant.

SECOND QUADRANT:

CH1, CH3, CH4

are off.

CH2 is operated.

Reverse current flows and I is negative through L CH2 D4 and E. When CH2 off D1 and D4 is ON and current i_d fed back to source. So

$E + L \frac{di}{dt}$ more than source voltage V_s .

As i_0 is negative and V_0 is positive, so second quadrant operation.

THIRD QUADRANT:

CH1 OFF, CH2 ON

CH3 operated. So, both V_0 and i_0 is negative.

When CH3 turned off negative current freewheels through CH2 and D4.

FOURTH QUADRANT:

CH4 is operated other are off.

Positive current flows through CH4 E L D2.

Inductance L stores energy when current fed to source through D3 and D2. V_0 is negative.

MODULE-3

INVERTERS

The device that converts dc power into ac power at desired output voltage and frequency is called an inverter.

Single phase voltage source inverters:

The inverter is a power electronic converter that converts direct power to alternating power. By using this inverter device, we can convert fixed dc into variable ac power which has a variable frequency and voltage. Secondly from this inverter, we can vary the frequency i.e we will be able to generate the 40HZ, 50HZ, 60HZ frequencies as of our requirement. If the dc input is a voltage source then the inverter is known as VSI (Voltage Source Inverter). The inverters need four switching devices whereas half-bridge inverter needs two switching devices. The bridge inverters are of two types they are half-bridge inverter and full-bridge inverter. This article discusses the half-bridge inverter.

The inverter is a device that converts a dc voltage into ac voltage and it consists of four switches whereas half-bridge inverter requires two diodes and two switches which are connected in anti-parallel. The two switches are complementary switches which means when the first switch is ON the second switch will be OFF. Similarly, when the second switch is ON the first switch will be OFF.

Where R_L is the resistive load, $V_s/2$ is the voltage source, S_1 and S_2 are the two switches, i_0 is the current. Where each switch is connected to diodes D_1 and D_2 parallelly. In the above figure, the switches S_1 and S_2 are the self-commutating switches. The switch S_1 will conduct when the voltage is positive and current is negative, switch S_2 will conduct when the voltage is negative, and the current is negative. The diode D_1 will conduct when the voltage is positive and current is negative, diode D_2 will conduct when the voltage is negative, and the current is positive.

Case 1 (when switch S_1 is ON and S_2 is OFF): When switch S_1 is ON from a time period of 0 to $T/2$, the diode D_1 and D_2 are in reverse bias condition and S_2 switch is OFF.

Applying KVL (Kirchhoff's Voltage Law)

$$V_s/2 - V_0 = 0$$

Where output voltage $V_0 = V_s/2$

Where output current $i_0 = V_0/R = V_s/2R$

In case of supply current or switch current, the current $i_{S1} = i_0 = V_s/2R$, $i_{S2} = 0$ and the diode current $i_{D1} = i_{D2} = 0$.

Case 2 (when switch S2 is ON and S1 is OFF): When switch S2 is ON from a time period of $T/2$ to T , the diode D1 and D2 are in reverse bias condition and S1 switch is OFF.

Applying KVL (Kirchhoff's Voltage Law)

$$V_s/2 + V_0 = 0$$

Where output voltage $V_0 = -V_s/2$

Where output current $i_0 = V_0/R = -V_s/2R$

In case of supply current or switch current, the current $i_{S1} = 0$, $i_{S2} = i_0 = -V_s/2R$ and the diode current $i_{D1} = i_{D2} = 0$.

The single-phase half-bridge inverter output voltage waveform is shown in the below figure.

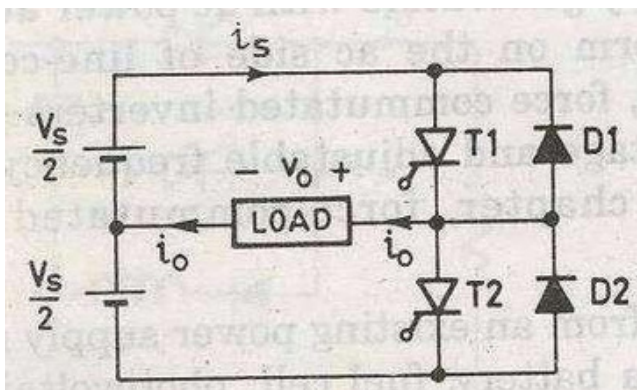

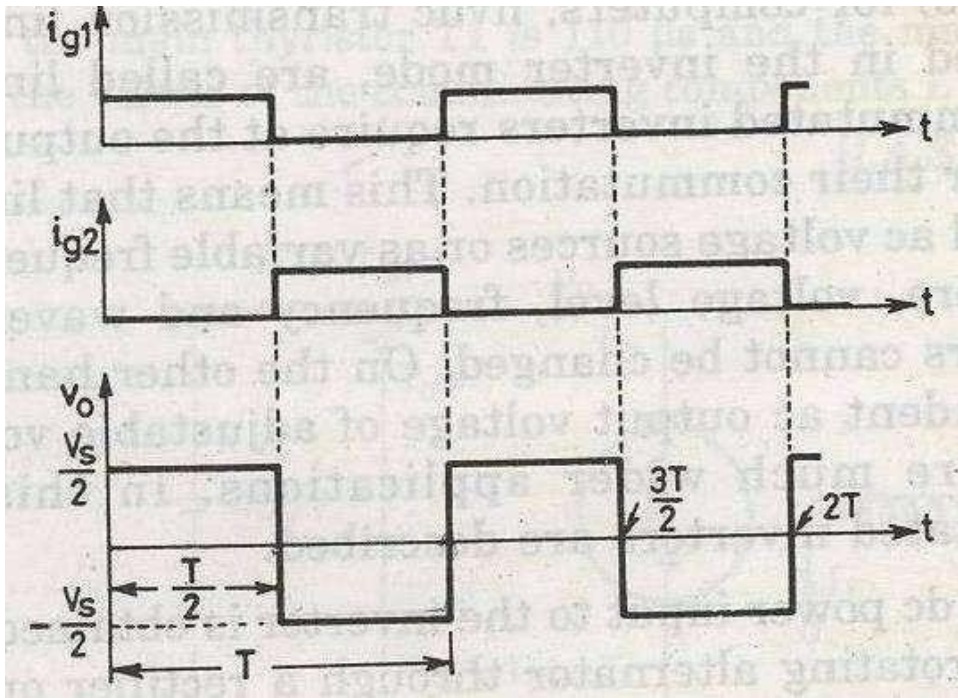

Single phase full bridge inverter:

The power circuit of a single-phase full bridge inverter comprises of four thyristors T1 to T4, four diodes D1 to D1 and a two wire DC input power source V_s . Each diode is connected in antiparallel to the thyristors viz. D1 is connected in anti-parallel to T1 and so on. The power circuit diagram of a single-phase full bridge inverter is shown in the figure below.

The working principle of single-phase full bridge inverter is based on the sequential triggering of thyristors placed diagonally opposite. This means, for half of time period, thyristors T3 & T4 will be triggered while for the remaining half of time period, T1 & T2 will be triggered. Only two thyristors are turned ON in half of the time period.

Carefully observe the waveform of the gating signal. You will notice that thyristors T1 & T2 are triggered simultaneously for a time $T/2$. Therefore, load is connected to source through T1 & T2 and hence, the load voltage is equal to the source voltage with positive polarity. This is the reason; the load voltage is shown positive & equal to V_s in the output voltage waveform.

As soon as the gate signal (ig_1 & ig_2) are removed, T1 and T2 get turned OFF. However, at the same instant gate signal (ig_3 & ig_4) are applied and hence, T3 & T4 are turned ON. When T3 & T4 are conducting, load gets connected to the source. The load voltage magnitude is again V_s but with reverse polarity. This is the reason; the output voltage is shown negative in the voltage waveform.

To summarize,

For the time $0 < t \leq (T/2)$, thyristors T1 & T2 conducts and load voltage $V_o = V_s$.

For the time $(T/2) < t \leq T$, thyristors T3 & T4 conducts and load voltage $V_o = -V_s$.

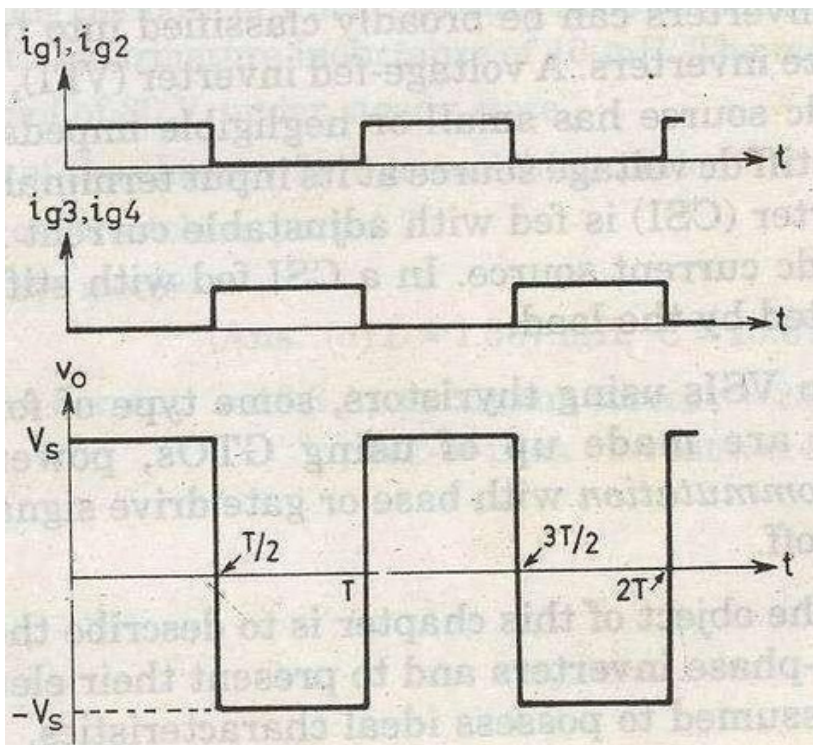
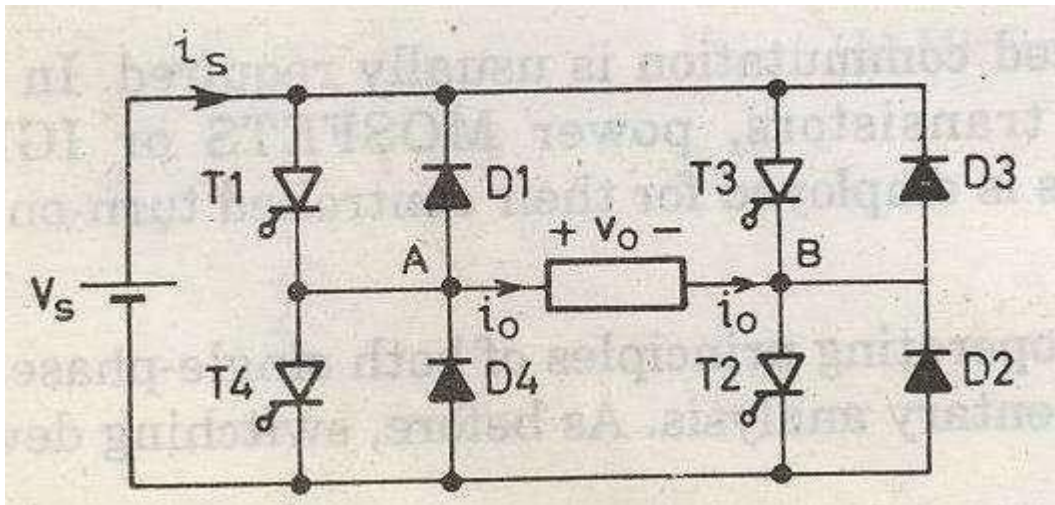

Purpose of Diodes D1 to D4:

If the load is purely resistive, there is no need to put diode D1 to D4 as the output voltage and current are always in phase. But unfortunately, for loads other than purely resistive, the load current (i_o) will not be in phase with the load voltage (v_o). For such case, the diode connected in anti-parallel with the thyristor will allow the current to flow when main thyristor is turned off. When these diode conducts, the energy is fed back to the DC source and hence, these diodes (D1 to D4) are called flyback diode.

Comparison between Half & Full Bridge Inverters:

The major difference between the single phase half and full bridge inverter is that former requires a three wire DC input source while the latter requires two wire DC source. Another difference between the two type of inverters are tabulated below:

Half Bridge Inverter	Full Bridge Inverter
It comprises of two thyristors and two free-wheeling diodes.	It consists of four thyristors and four flyback diodes.
The magnitude of load / output voltage is half of the magnitude of input DC source.	The magnitude of load voltage is equal to the magnitude of DC input source. This means, the magnitude of output voltage is twice the magnitude of load voltage for half bridge inverter.
The main drawback of this inverter is the requirement of three wire DC input supply.	This drawback of half bridge inverter is overcome by full bridge inverter as it requires two wire DC source.
-	The output power of full bridge inverter is four times that of for half bridge inverter.

SERIES INVERTER: IT'S WORKING, OPERATION AND WAVEFORM

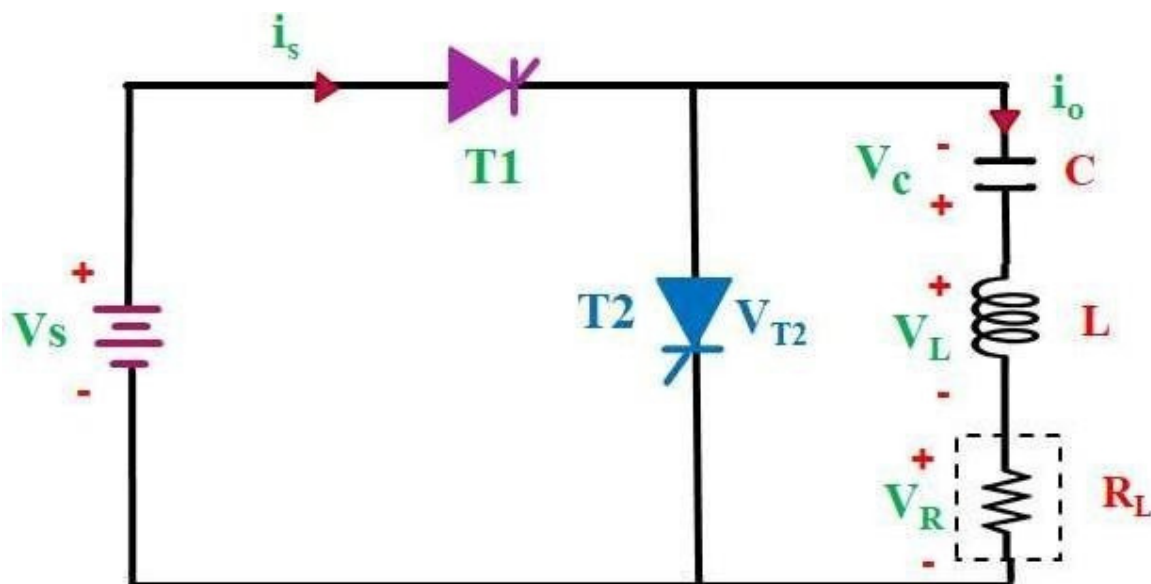

Inverter is an electronic circuit which converts DC power into AC power. The inverter circuit in which the commutating elements L and C are connected in series with the load to form an under damped circuit is called a series inverter. This circuit is also called load commutated or self-commutated inverter.

Operation of Series inverter

The whole operation is divided into three modes:

Mode-I (T1 on and T2 off): In this mode we give firing pulse to thyristor T1 so, T1 get turned on and T2 thyristor is turned off initially. So, current flow from supply V_sT1.....load.....back to V_s .

The nature of the load current is alternating due to under damped circuit. So, this time capacitor (C) starts charging gradually from $-V_s$ to its max voltage. This time inductor (L) also get charge. When the load current becomes maximum the voltage across capacitor becomes $+V_s$. When the load current becomes zero at point the voltage across capacitor becomes $+2V_s$. Then the load current becomes zero the thyristor T1 automatically turns off at point a.

Mode- II (T1 and T2 both off): This time thyristor T1 turns off because the load current becomes zero from point a to b. In this time duration the thyristor T1 and T2 are turned off and voltage across capacitor becomes equal to $+2V_s$.

Mode III (T1 off and T2 on): In this mode we give firing pulse to thyristor T2. So, T2 get turned on. In this time capacitor start discharging its energy from $+2V_s$ to $-V_s$ through thyristor T2 and R – L circuit. Due to capacitor discharging reverse current flow across the load. Now at point C thyristor T2 turns off automatically due to load current becomes zero. The thyristor T2 turns off during point C to D and thyristor T1 again turns on. In this way cycle repeat. Now, we see in the waveform the time duration ab and cd is called as *dead zone*.

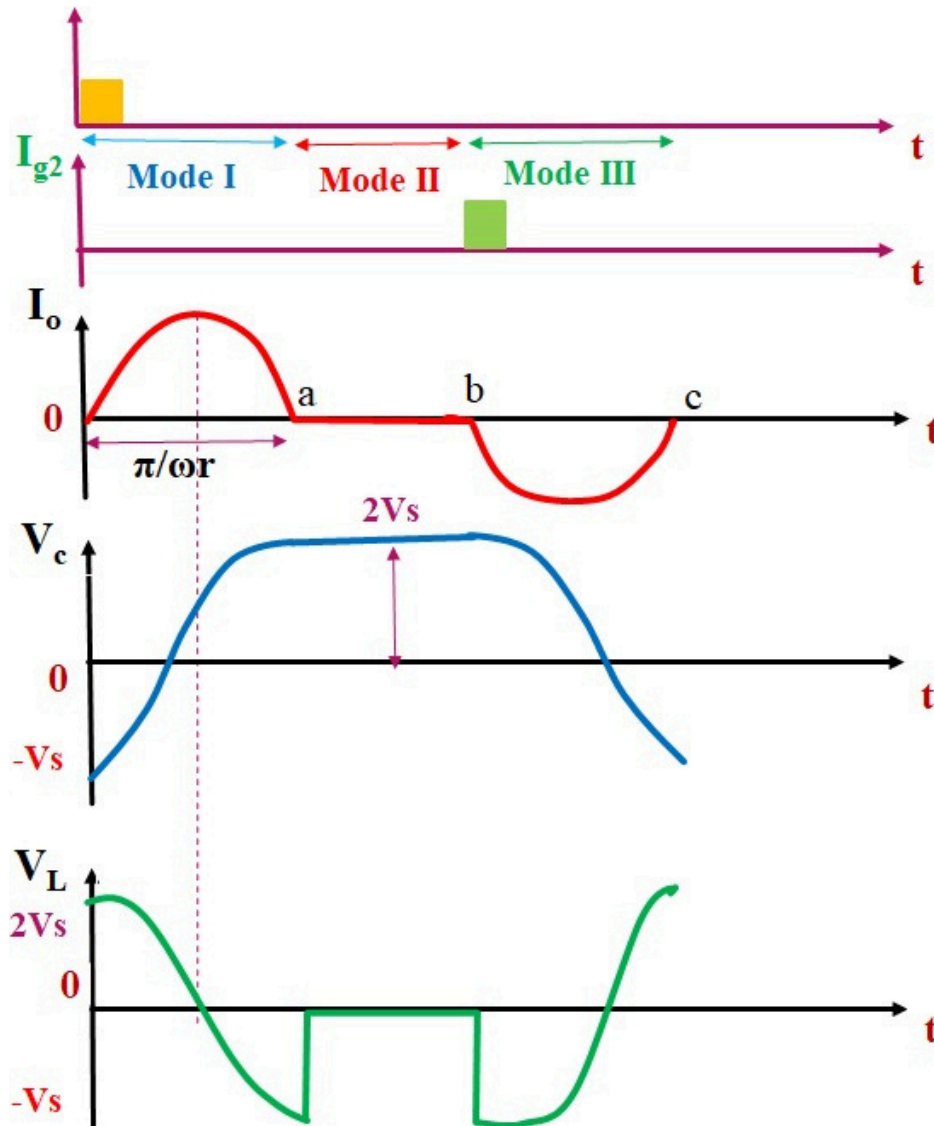

Application of Series Inverter

Series Inverter is basically used in high frequency applications (200 Hz to 100 KHz) because it generates high frequency sinusoidal waveform.

This circuit is called load commutated inverter because the load component (L and C) is responsible to turn off the thyristor. It is called self-commutated inverter because in this circuit anode current itself become zero resulting the thyristor turned off.

The Circuit Diagram of Series Inverter is shown in the figure. It consists of two thyristors (T1 and T2). The thyristor T1 and T2 are turn on appropriately to get the output voltage of desired frequency. This circuit consist of L and C connected in series with load (R).

Initially we considered that thyristor T2 is turned off and the polarity across capacitor is shown in figure.

PARALLEL INVERTER: IT'S BASICS, OPERATION AND WAVEFORM

Parallel inverter is an electronic circuit which converts DC power into AC power. The inverter circuit in which the commutating component C (capacitor) is connected in parallel with the load via transformer called a parallel inverter. This circuit is also called Push-pull inverter.

Parallel Inverter working is similar to the class B commutation. Parallel inverter has important role in Uninterrupted Power Supply (UPS).

Parallel inverter circuit consist of two thyristor T1 and T2, a transformer, inductor L and a commutating component C. Capacitor (C) is connected in parallel with the load via transformer therefore it is called a parallel inverter. And inductor (L) is connected in series with supply to make the source current constant. Here we also use a center -tapped transformer. Centre tapping is done in the primary winding of transformer so, primary winding is divided into two equal halves ao and ob

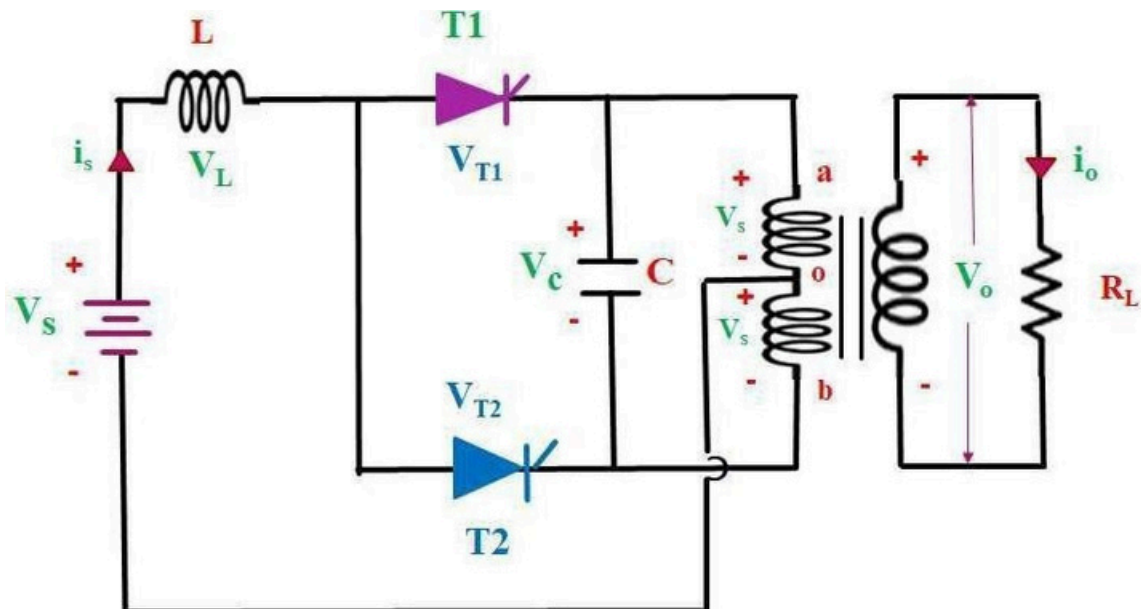

Operation of Parallel Inverter:

The operation is divided into four modes:

Mode I ($0 < t < t_1$): In this mode we give firing pulse to thyristor T1 and T1 get turned on and T2 is turned off. Current flow from Supply V_s T1.... a0 (upper half of primary winding) back to V_s . As a result, V_s voltage is induced across upper as well as lower half of the primary winding of transformer. And V_s voltage is induced in secondary winding.

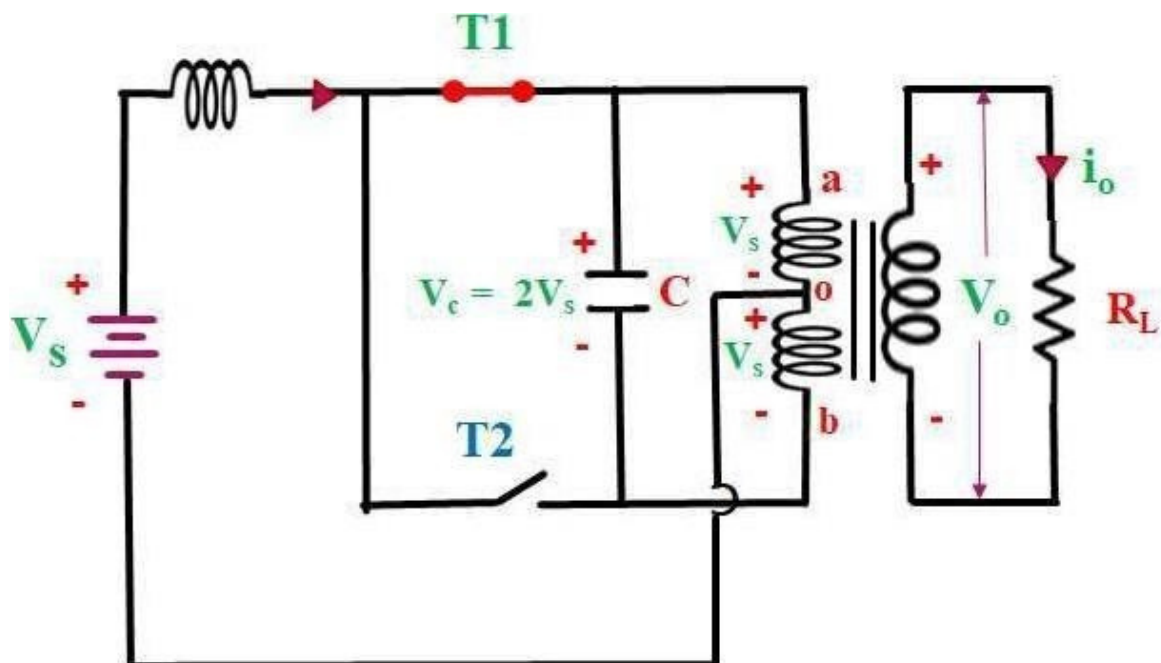

So, output voltage across load is V_s .

So, the total voltage across primary winding is $2V_s$. Here capacitor is connected in parallel with primary winding therefore capacitor charge with $2V_s$ voltage with upper plate is positive and lower plate is negative.

Mode II ($t_1 < t < t_3$): In this duration we give firing pulse to thyristor T2 and T2 get turned on. At this time capacitor start discharging through T1 therefore T1 turned OFF. This time current flow from supply V_s T2.... b0 (lower half of primary winding) back to V_s .

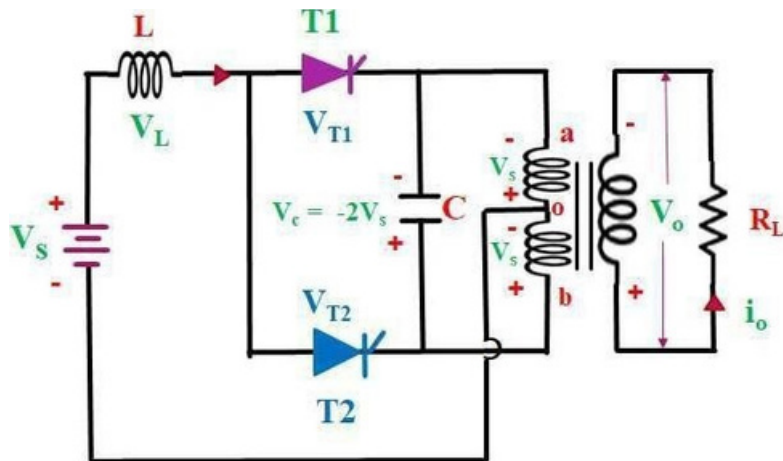

Now this time capacitor charged with upper plate is negative, from $+2V_s$ at $t=t_1$ to $-2V_s$ at $t=t_2$. Load voltage also changes from V_s at $t=t_1$ to $-V_s$ at $t=t_2$. After $t=t_2$ voltage across capacitor is maintain constant $-2V_s$ between $t= t_2$ to t_3 .

So, load voltage is also constant $-V_s$. Mode III ($t_3 < t < t_4$): In this mode

again, we give firing pulse to thyristor T1

and T1 get turned on. At this time capacitor start discharging through T2 therefore T2 turned OFF. This time current flow from supply V_s T1....

ao

(upper half of primary winding) back to V_s . So, the total voltage across primary winding is $2V_s$.

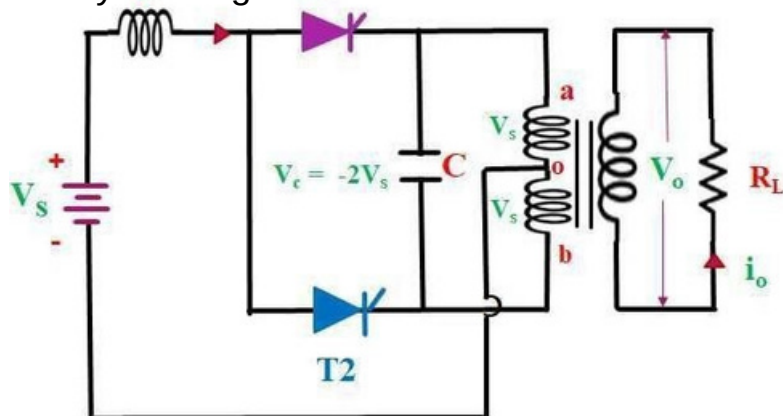

Now this time capacitor charged with upper plate is positive, from $-2V_s$ at $t=t_3$ to $+2V_s$ at $t=t_4$. Load voltage also changes from V_s at $t=t_3$ to $-V_s$ at $t=t_4$.

So, output voltage across load is V_s .

Now draw the waveform

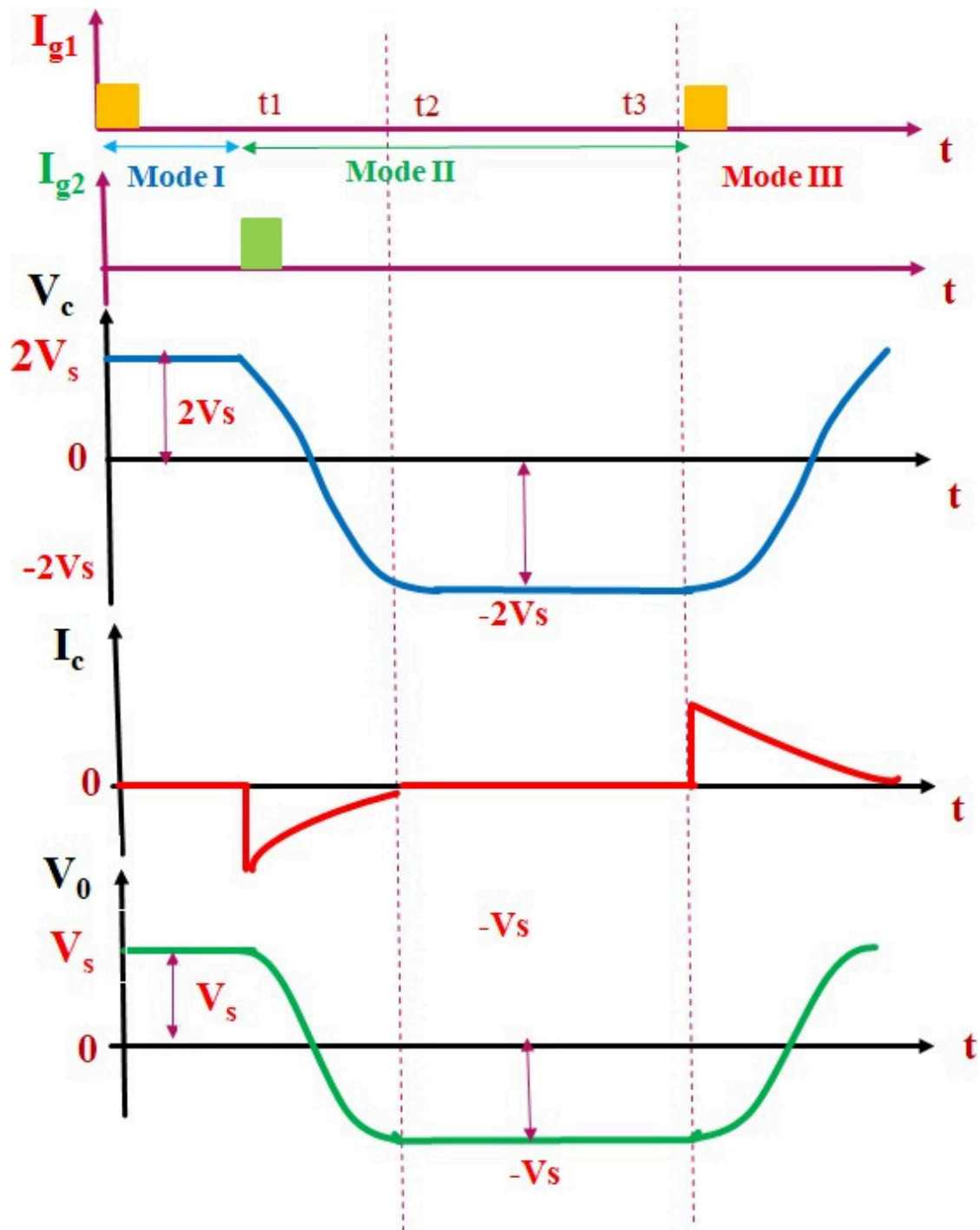

Waveform of parallel Inverter 1) I_{g1} is the gate current given to T1 2) I_{g2} is the gate current given to T2. 3) V_c capacitor voltage 4) I_c current across capacitor 5) V_o output voltage waveform

CYCLOCONVERTER

A **cycloconverter** (also known as a cycloconverter or CCV) converts a constant voltage, constant frequency AC waveform to another AC waveform of a different frequency. A cycloconverter achieves this through synthesizing the output waveform from segments of the AC supply (without an intermediate DC link).

The main forms of electrical energy commonly available are constant DC (Direct Current) and constant AC (Alternating Current). Often though, we need to swap between AC and DC, change the frequency, or swap from constant to variable power. For these conversion purposes, several converters like inverters, rectifiers, DC choppers and **cycloconverters** are employed. The cycloconverters can in fact transfer AC power of a fixed frequency to the AC power of a different frequency (see figure 1).

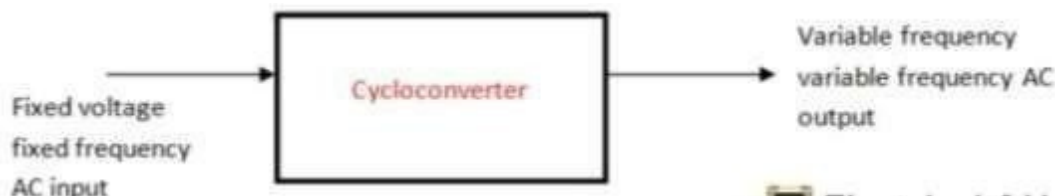

STEP UP CYCLOCONVERTER Step-up cycloconverter is a single phase to single phase device which converts input AC power at one frequency to output power at a different frequency. The output frequency is more than the input frequency for this cycloconverter.

Single phase to single phase means that both the input power and output power are single phase. This article presents the working principle of Step-up Cycloconverter with relevant circuit diagram and waveforms.

Working Principle of Step-up Cycloconverter:

The working principle of a step-up cycloconverter is based on switching of thyristors in a proper sequence. The thyristor acts as a power switch.

These switches are arranged in a specific pattern so that the output power is available for both the positive and negative half of the input power supply. **Forced commutation technique is used to turn OFF the thyristor.**

Two circuit configurations are possible for step-up cycloconverter: **Mid-point Type and Bridge Type**. In this article, we will consider mid-point type of circuit arrangement for better understanding of working principle.

Circuit Diagram:

Figure below shows the circuit diagram of Mid-point step-up cycloconverter:

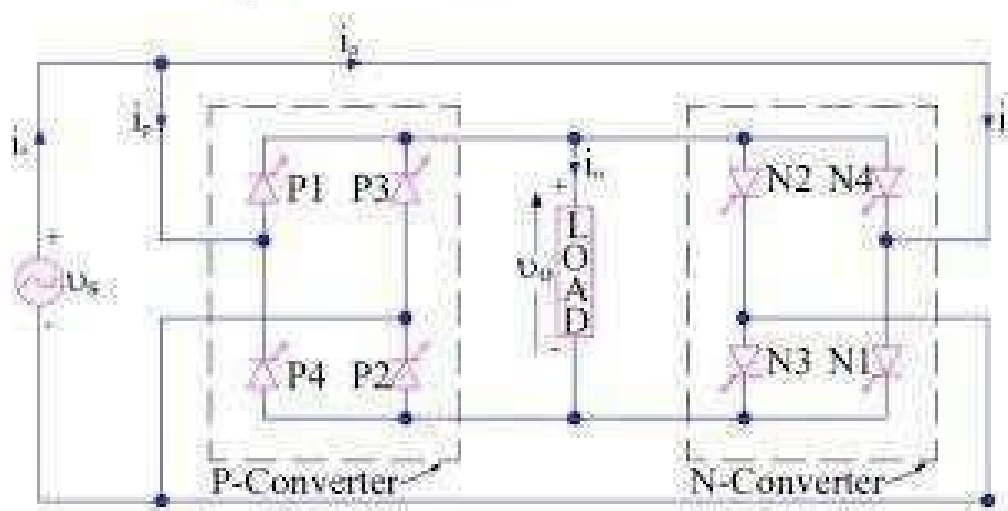
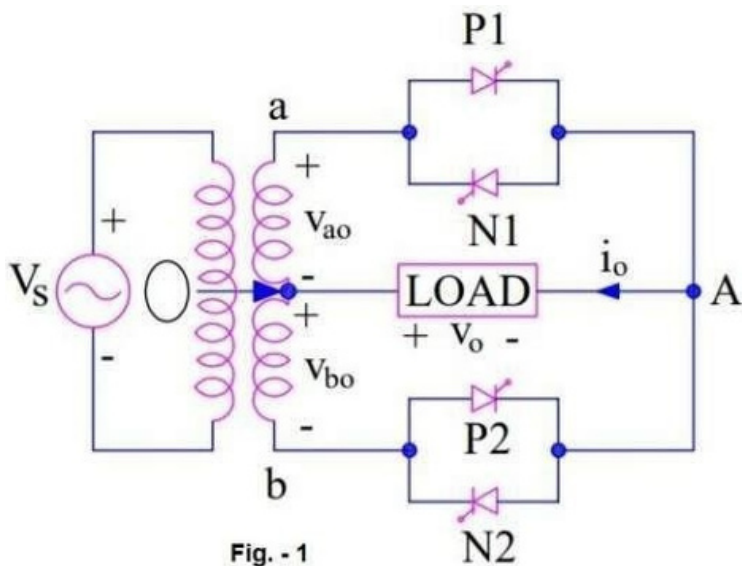

The circuit consists of a single phase transformer with mid tap on the secondary winding and four thyristors. Two of these thyristors P1 & P2 are for positive group. Here positive group means when either P1 or P2 conducts, the load voltage is positive. Other two thyristors N1 & N2 are for negative group. Load is connected between secondary winding mid-point O and terminal A. The load is assumed resistive for simplicity. Assumed positive direction for voltage and current are marked in the circuit diagram.

Operation of Step-up Cycloconverter:

During the positive half cycle of input supply voltage, positive group thyristors P1 & N2 are forward biased for $\omega t = 0$ to $\omega t = \pi$. As such SCR P1 is fired to turn it ON at $\omega t = 0$ such that load voltage is positive with terminal A positive and O negative. The load voltage, thus, follows the positive envelop of the input

supply voltage. At some time instant $\omega t = \omega t_1$, the conducting thyristor P1 is force commutated and the forward biased thyristor N2 is fired to turn it ON. During the period N2 conducts, the load voltage is negative because O is positive & A is negative this time. The load or output voltage traces the negative envelop of the supply voltage. This is shown in figure below.

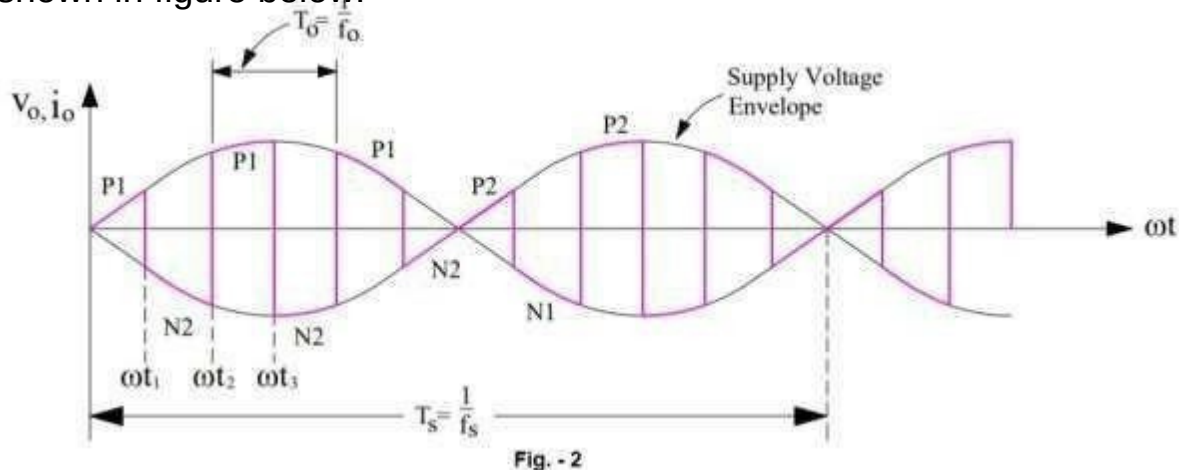

At $\omega t = \omega t_2$, N2 is force commutated and P1 is turned ON. The load voltage is now positive and follows the positive envelop of the supply voltage. At $\omega t = \pi$, terminal "b" is positive with respect to terminal "a"; both SCRs P2 & N1 are therefore forward biased from $\omega t = \pi$ to $\omega t = 2\pi$. AT $\omega t = \pi$, N2 is force commutated and forward biased SCR P2 is turned ON. The load voltage is positive and follows the positive envelop of supply voltage.

If the supply frequency is f_s and output frequency is f_o , P2 will be force commutated at $\omega t = (\frac{1}{2f_s}) + (\frac{1}{2f_o})$. Carefully note this from the waveform shown in the figure-2.

When P2 is force commutated, forward biased SCR N1 is turned ON. This time, the load voltage is negative and follows the negative envelop of the supply input.

In this manner, SCRs P1, N2 for the first half cycle; P2, N1 in the second half cycle and so on are switched alternately between positive and negative envelopes at a high frequency. This results in output frequency f_o more than the input supply frequency f_s . In our example of figure-2, note that there is a total of 6 cycles of output in one cycle of input supply. This means that frequency of output voltage is 6 times of input frequency i.e. $f_o = 6f_s$.

STEP DOWN CYCLOCONVERTER Step-down cycloconverter is a device which steps down the fixed frequency

power supply input into some lower frequency. It is a frequency changer. If f_s &

f_o are the supply and output frequency, then $f_o < f_s$ for this cycloconverter.

The most important feature of step-down cycloconverter is that it does not require force commutation. Line or Natural Commutation is used which is provided by the input AC supply. **Circuit Diagram:**

There are two circuit configurations of a step-down cycloconverter: **Mid-point and Bridge type**. This article, focuses on the mid-point type. The

operation for continuous and discontinuous type of RL load is explained for mid-point type cycloconverter.

Figure below shows the circuit diagram of mid-point type cycloconverter. The

positive direction of voltage and current are marked in the diagram.

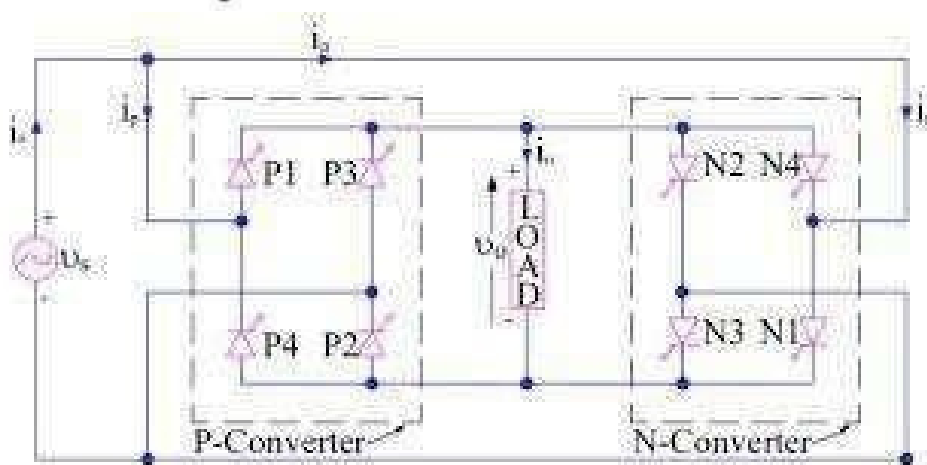
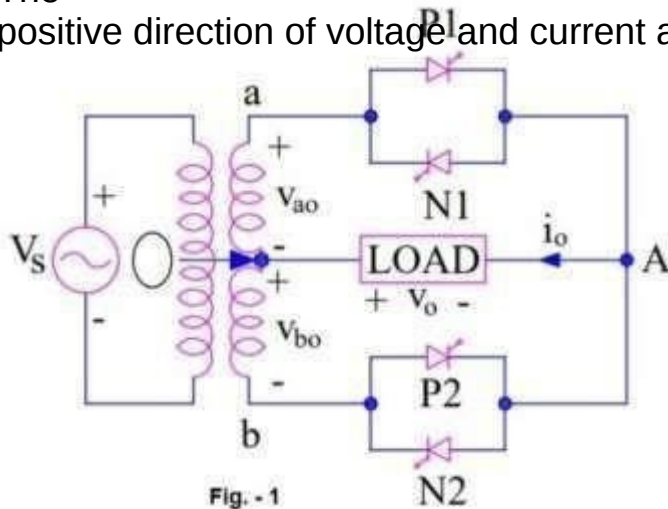

The working principle of step-down cycloconverter is explained for discontinuous and continuous load current. The load is assumed to be comprised of resistance (R) & inductance (L).

Discontinuous Load Current:

For positive cycle of input AC supply, the terminal A is positive with respect to point O. This makes SCR P1 forward biased. The forward biased SCR P1 is triggered at $\omega t = 0$. With this, load current i_o starts building up in the positive direction from A to O. Load current i_o becomes zero at $\omega t = \beta > \pi$ but less than $(\pi + \alpha)$. Refer figure-2. The thyristor P1 is thus, naturally commutated at $\omega t = \beta$ which is already reversed biased after π .

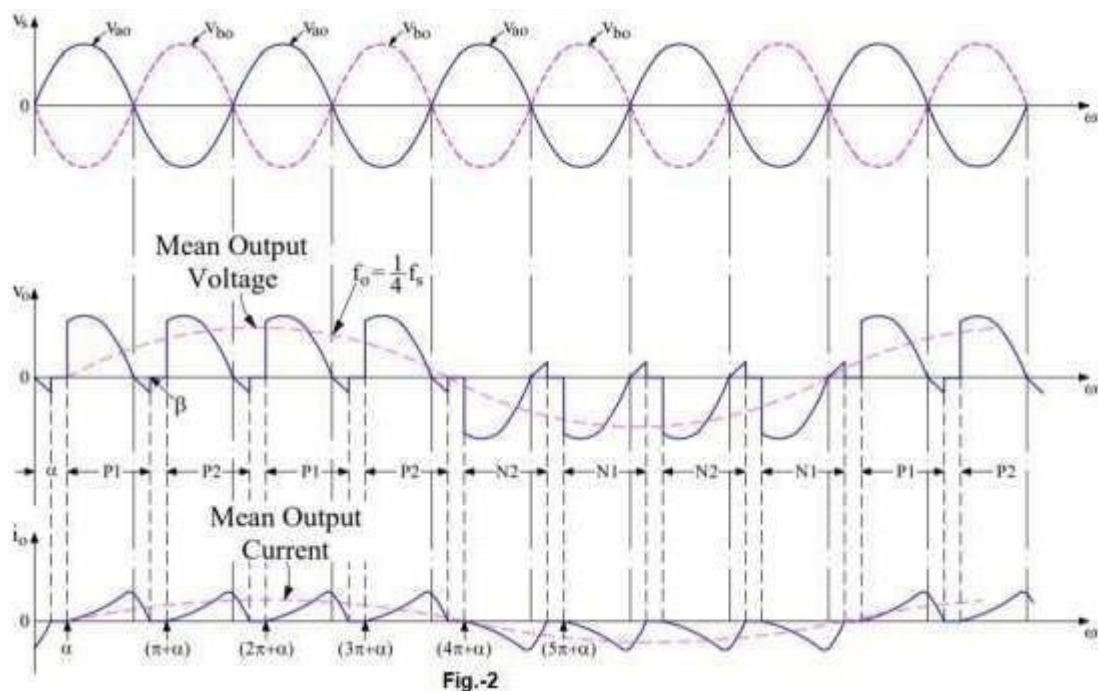

After half a cycle, b is positive with respect to O. Now forward biased thyristor P2 is fired at $\omega t = (\pi + \alpha)$. Load current is again positive from A to O and builds up from zero as shown in figure-2. At $\omega t = (\pi + \beta)$, i_o decays to zero and P2 is naturally commutated. At $\omega t = (2\pi + \alpha)$, P is again turned ON. Load current in figure-2 is seen to be discontinuous.

After four positive half cycles of load voltage and load current, thyristor N2 is gated at $(4\pi + \alpha)$ when O is positive with respect to b. As N2 is forward biased, it starts conducting but the direction of load current is reverse this time i.e. it flows from O to A. After N2 is triggered, O is positive with respect to "a" but before N1 is fired, i_o decays to zero and N2 is naturally commutated. Now when N1 is gated at $(5\pi + \alpha)$, i_o again builds up but it decays to zero before thyristor N2 in sequence is again gated.

In this manner, four negative half cycles of load voltage and load current, equal to number of positive half cycles of load voltage & current, are generated. Now P1 is again triggered to fabricate four positive half cycles of load voltage and so

on. It may be noted that, natural commutation is achieved for discontinuous current load. From figure-2, the waveform of mean load voltage & current may be noted. It is clear that the output frequency of load voltage & current is $(\frac{1}{4})$ times of input supply frequency.

Continuous Load Current:

When “a” is positive with respect to O in figure-1, P1 is triggered at ωt positive output voltage appears across load and load current starts building up as shown in figure-3. At $\omega t = \pi$, supply and load voltages are zero. After $\omega t = \pi$, P1 is reversed biased. As load current is continuous, P1 is not turned OFF at $\omega t = \pi$.

When P2 is triggered in sequence at $(\pi+\alpha)$, a reverse voltage appears across P1, it is therefore turned OFF by natural commutation.

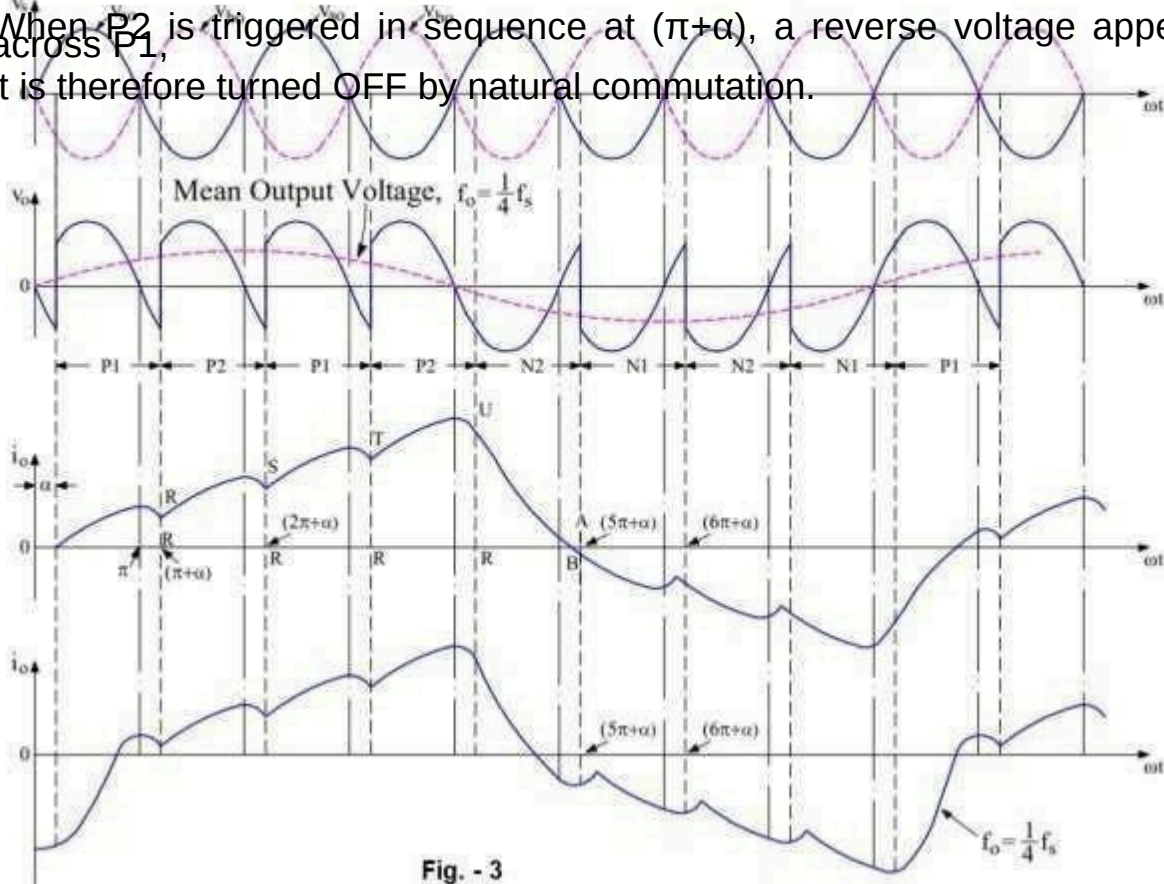

Fig. - 3

When P1 is commutated, load current has builds up to a value equal to RR. With the tun ON of P2 at $(\pi+\alpha)$, output voltage is again positive. As a consequence, load current builds up further than RR as shown in figure-3. At $(2\pi+\alpha)$, when P1 is again turned ON, P2 is naturally commutated and load current through P1 builds up beyond RS. At the end of four positive half cycles of output voltage, load current is RU. When N2 is triggered after P2, load is subjected to negative voltage cycle and load

current i_o decreases from RU to negative AB. Now N2 is commutated and N1 is gated at $(5\pi+\alpha)$. Load current i_o becomes more negative than AB at $(6\pi+\alpha)$, this is because with N1 ON, load voltage is negative. For four negative half cycles

of output voltage, current i_o is shown in figure-3. Load current waveform is redrawn in the last waveform of figure-3.

It may be seen from the waveform of load current that it is symmetric with

respect to ωt axis. The mean waveform of load voltage is also shown in load

voltage waveform. It is clear from the load current and mean load voltage waveform that the output frequency is one fourth of the input supply frequency

i.e. $f_o = (1/4)f_s$.

MODULE-4

Application of Power Electronics

Below is an attempt to briefly present the diaspora of power electronics.

application of power electronics

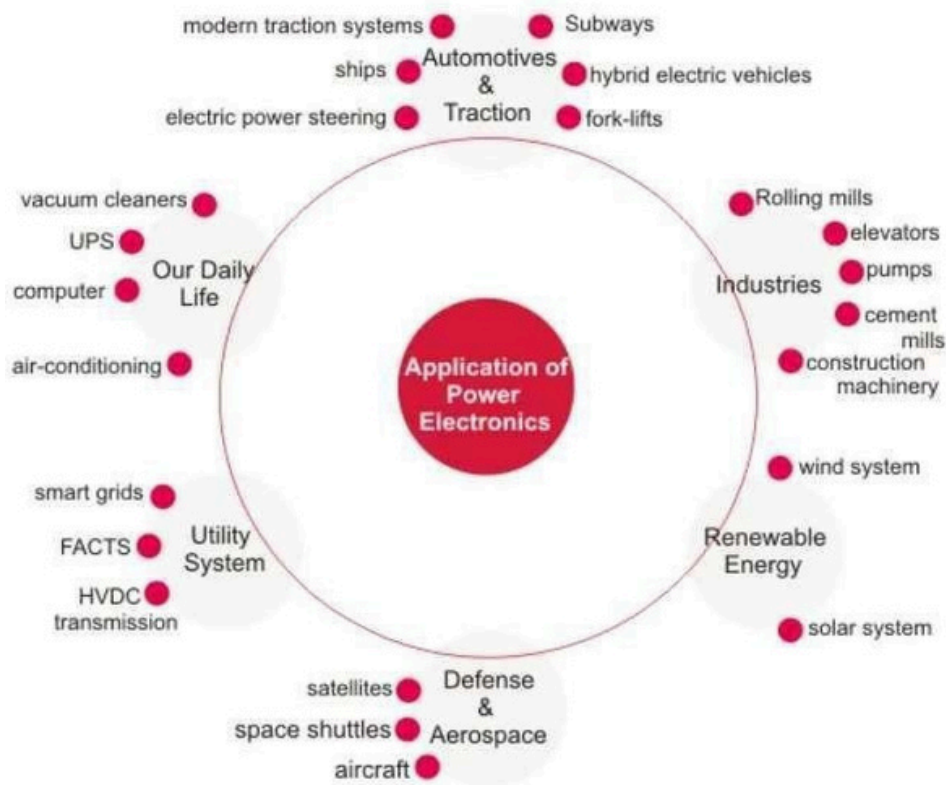

Our Daily Life: If we look around ourselves, we can find a whole lot of power electronics applications such as a fan regulator, light dimmer, air-conditioning, induction cooking, emergency lights, personal computers, vacuum cleaners, UPS (uninterrupted power system), battery charges, etc.

Automotive and Traction: Subways, hybrid electric vehicles, trolley, fork-lifts, and many more. A modern car itself has so many components where power electronic is used such as ignition switch, windshield wiper control, adaptive front lighting, interior lighting, electric power steering and so on. Besides power electronics are extensively used in modern traction systems and ships.

Industries: Almost all the motors employed in the industries are controlled by power electronic drives, for eg. Rolling mills, textile mills, cement mills, compressors, pumps, fans, blowers, elevators, rotary kilns etc. Other applications include welding, arc furnace, cranes, heating applications, emergency power systems, construction machinery, excavators etc.

Défense and Aerospace: Power supplies in aircraft, satellites, space shuttles, advance control in missiles, unmanned vehicles and other defense equipments.

Renewable Energy: Generation systems such as solar, wind etc. needs power conditioning systems, storage systems and conversion systems in order to become usable. For example solar cells generate DC power and for general application we need AC power and hence power electronic converter is used.

Utility System: HVDC transmission, VAR compensation (SVC), static circuit breakers, generator excitation systems, FACTS, smart grids, etc.

Factors Affecting the Speed of D.C. Motor

According to the speed equation of a d.c. motor we can write,

$$N \propto \frac{E_b}{\phi} \propto \frac{V - I_a R_a}{\phi}$$

The factors Z, P, A are constants for a d.c. motor. But as the value of armature resistance R_a and series field resistance R_{se} is very small, the drop $I_a R_a$ and $(R_a + R_{se})$ is very small compared to applied voltage V .

Hence neglecting these voltage drops the speed equation can be modified as, $N \propto \frac{V}{\phi}$ as $E_b = V$

Thus, the factors affecting the speed of a d.c. motor are,

1. The flux ϕ
2. The voltage across the armature
3. The applied voltage V

depending upon these factors the various methods of speed control are,

1. Changing the flux ϕ by controlling the current through the field winding called flux control methods.
2. Changing the armature path resistance which in turn changes the voltage applied across the armature called rheostatic control.
3. Changing the applied voltage called voltage control method.

DC Motor speed Control through Converters:

DC motor control is conveniently and efficiently achieved by phase-controlled converters wherein the ac input voltage is converted to a controlled dc output.

The commutation process, the transfer of current from one thyristor to the other,

in these converters is the inexpensive **natural** or **line commutation**.

As, an incoming thyristor is turned-on, it reverse-biases the outgoing thyristor, turning

it off. No additional commutation circuitry is therefore required. The

conversion efficiency in these converters is above 95% because of relatively

low losses in thyristors. These converters are used in the speed

control of fractional- kW dc motors as well as in large motors employed in variable-

speed reversing drives for rolling mills with motor ratings as large as several

MWs.

In certain types of converters (**semi-converters**) a diode known as a, **free-**

wheeling diode is connected across motor terminals to allow for dissipation of

energy stored in motor inductance and to provide for continuity of motor

current when the thyristors are blocked. It also provides protection against

transient overvoltage.

Single Phase Half Wave Converter: Figure 11.14 shows a single-phase

half-wave converter for controlling a separately excited DC Motor. It requires a single thyristor and a free-

wheeling diode. In this circuit the motor current is always discontinuous, resulting in

poor

motor performance. This type of converter is employed only for motors

below 400 W. It will not be described in detail here; these easily follow from the

description of waveforms (voltage and current) for the semi-converter.

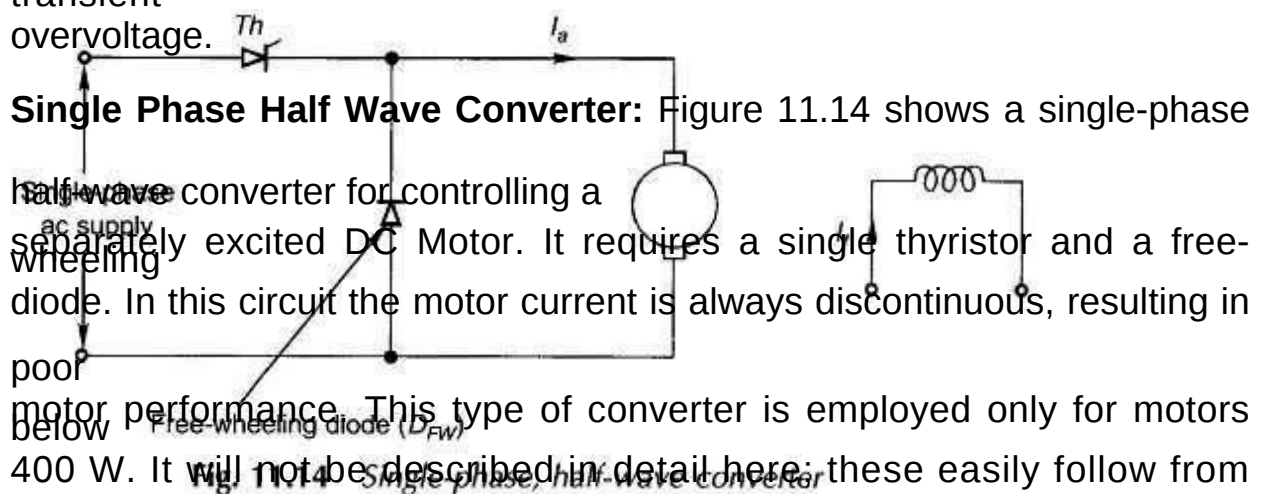

Fig. 11.14 Single phase, half-wave converter

Semi-Converter feeding a Separately excited DC Motor: This is a one-quadrant converter (Fig. 11.15a) which gives voltage and current of one polarity at dc terminals. It therefore does not provide for regenerative braking, i.e. power flow from DC Motor Control to the ac supply.

Where regeneration is not required, this converter is used for reasons for economy.

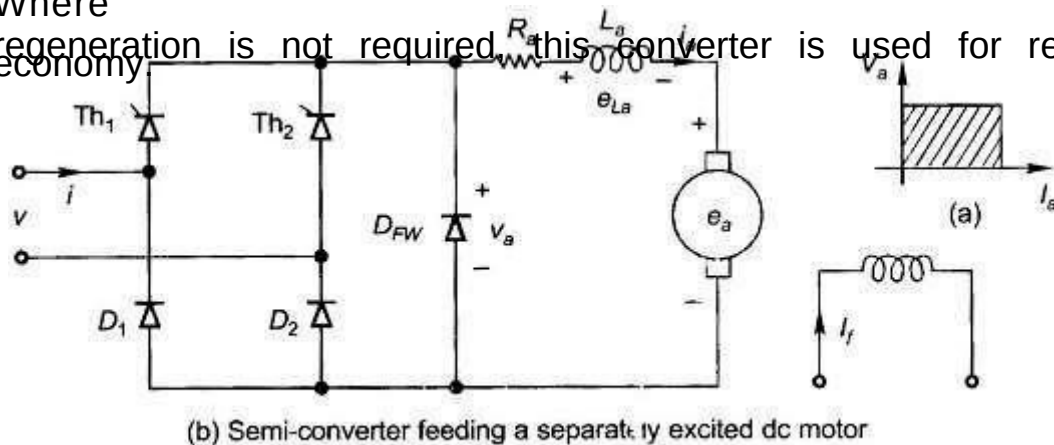

Fig 11.15

Figure 11.15(b) gives the circuitry of a semi-converter feeding a separately excited DC Motor Control. The armature resistance R_a and inductance L_a are shown lumped in series with an armature-induced emf e_a while the armature terminal voltage is v_a . It has two thyristors, two diodes and a free-wheeling diode (connected across motor terminals). It will be assumed that in steady-state operation the armature current is continuous over the whole range of operation.

Typical steady-state voltage and current waveforms are shown in Fig. 11.16.

The thyristor Th1 is fired at angle α and Th2 at angle $\pi + \alpha$ with respect to the supply voltage v and the process is repeated continuously.

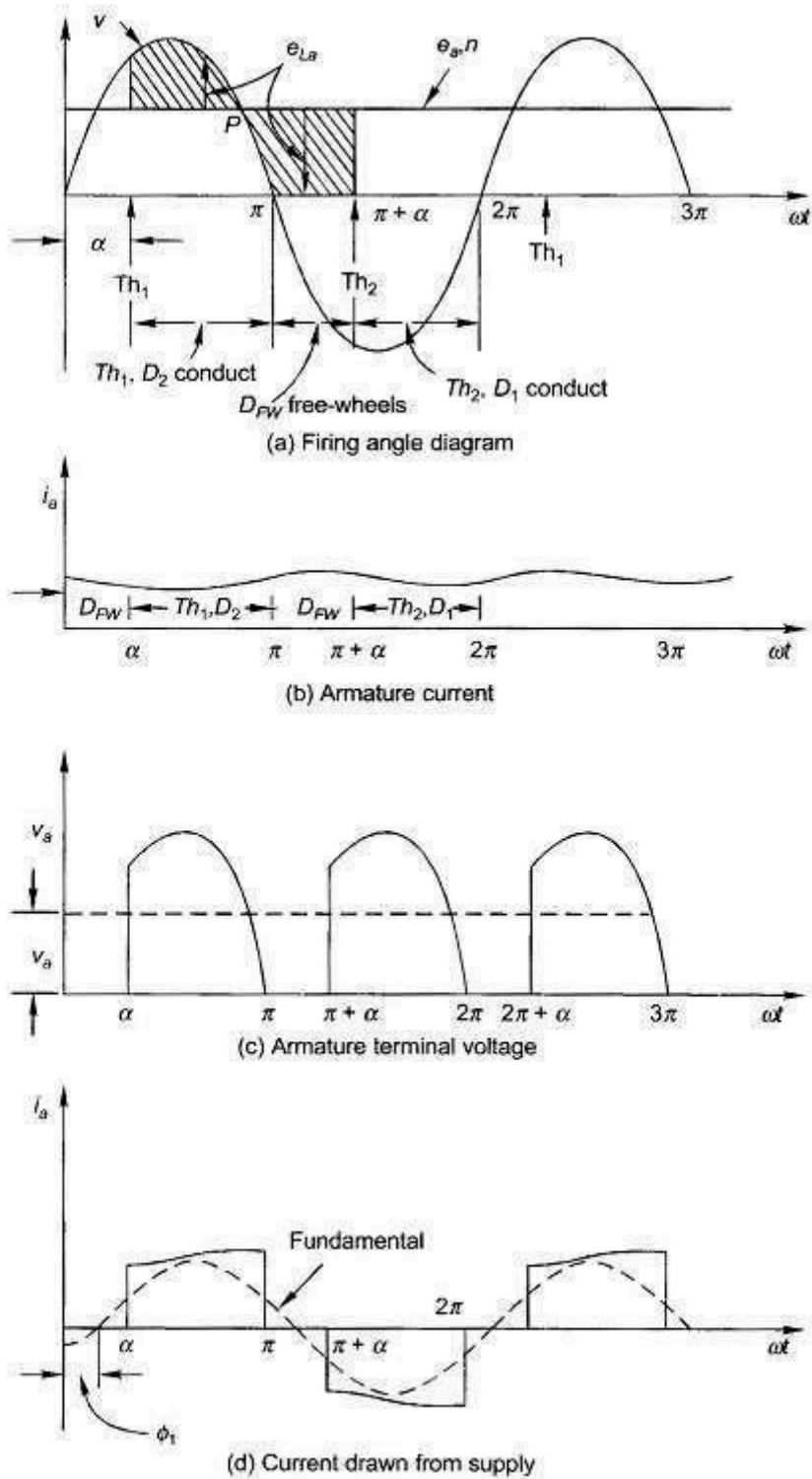

Fig. 11.16 Voltage and current waveforms of semiconverter feeding separately excited dc motor; continuous armature current

Under steady conditions, as Th1 is fired ($\omega t = \alpha$), Th1 and D2 conduct and the motor is connected to the supply, i.e. $v_a = v$. At $\omega t = \pi$, v_a tends to become negative as the input voltage polarity changes. This causes DFW, the free-wheeling diode, to become forward-biased and the armature current flowing through Th1D2 is transferred to DFW, which means that Th1 commutates (naturally). The

motor terminals are shorted through DFW for the free-wheeling period $\pi < \omega t < \pi + \alpha$ providing for continuity of the armature current during this period when the motor remains disconnected from the supply. At $\omega t = \pi + \alpha$, Th2 is fired and Th2D1 conduct, causing DFW to become reverse-biased and therefore open-circuited. The motor is once again connected positively to the supply for the next period of $\pi + \alpha < \omega t < 2\pi$. This process repeats continuously.

Various voltage and current waveforms of a separately excited DC Motor Control fed through a semi-converter are shown in Fig. 11.16. Though the voltage across motor terminals (Fig. 11.16(c)) contains harmonics over

and $\int_0^{\omega t} (v - e_a) d(\omega t)$; assuming R_a negligible (11.1)

above a steady dc value, it is rightly assumed here that the motor does not respond to these harmonics and therefore runs at constant speed (n) up to the point P shown in Fig. 11.16(a); $v > e_a$ so that the motor current increases. So does the motor emf e_a . During this period, apart from the energy being delivered to the motor, energy is also being stored in motor inductance (L_a). Beyond the point P, $v < e_a$ and the motor current begins to decrease. This also implies the reversal of voltage across the motor inductance which now feeds

energy into the system. During the free-wheeling period ($\pi < \omega t < \pi + \alpha$), the diode continues to be forward-biased by the reversal of the inductive voltage.

During this period a part of the energy stored in motor inductance is consumed

to feed the mechanical load. The motor current, speed and emf, therefore, all

reduce. This process then repeats over the next period ($\pi + \alpha < \omega t < 2\pi + \alpha$) via Th2D1 and later through DFW. The current drawn from the supply shown in Fig.

11.16(d) is that part of the armature current which flows over the periods (α, π),

($\pi + \alpha, 2\pi$), ... when the motor is connected to the supply. It is not necessary to use the free-wheeling diode. In its absence at $\omega t = \pi$, D1 becomes forward-biased so that free-wheeling takes place through Th1D1 till Th2 is fired. At $\omega t = 2\pi$ free-wheeling takes place through Th2D2 and so on.

It should be observed from Fig. 11.16(d) that the fundamental of the current

drawn from the mains lags the voltage by an angle $\Phi_1 (< \alpha)$.

Discontinuous Armature Current: The armature current becomes

discontinuous for large values of the firing angle, high speed and low values of torque. The motor performance deteriorates with

discontinuous armature current. The ratio of peak to average and rms to

average

armature current increases. It is, therefore, desirable to operate the motor

in the continuous current mode. To achieve this, an external armature circuit

choke

may be used, which decreases the rate of current decay during the free-

wheeling operation.

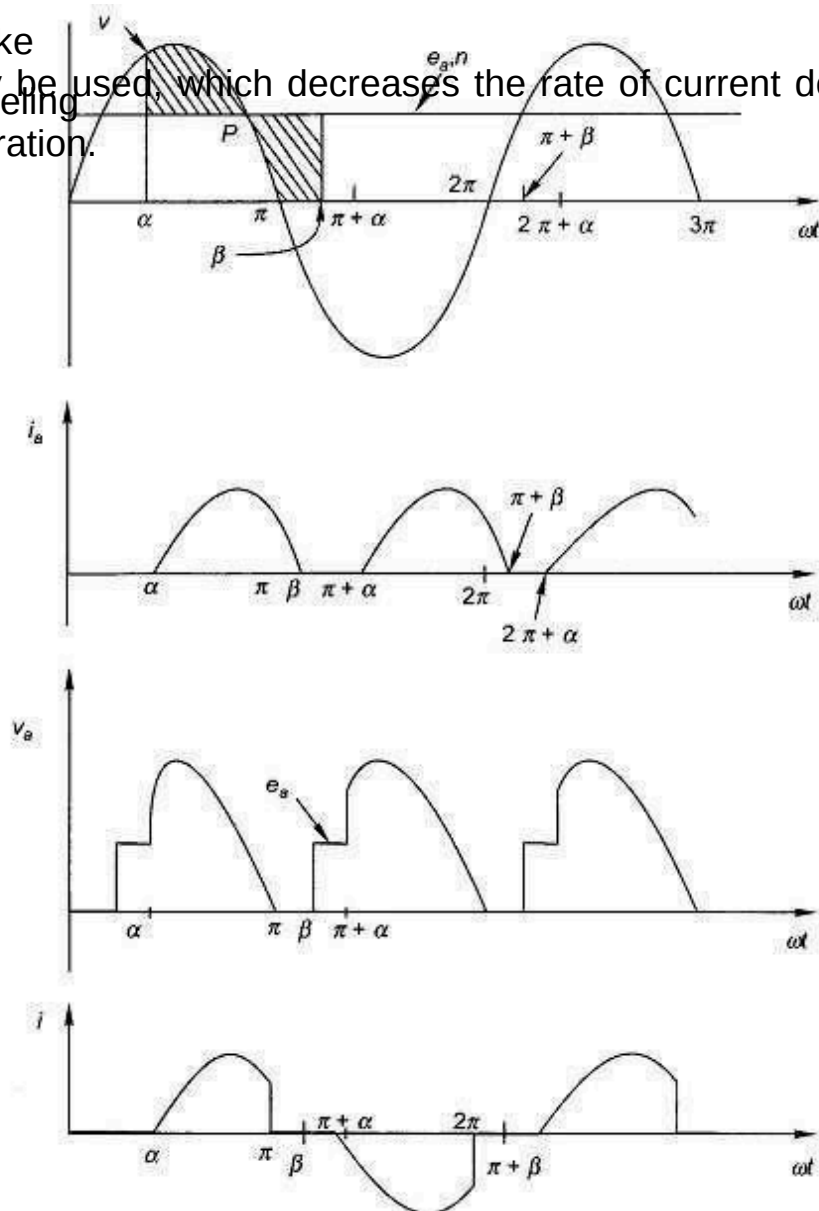

Fig. 11.17 Voltage and current waveforms of semiconverter feeding separately excited dc motor; discontinuous armature current

The voltage and current waveforms for semi-converter with discontinuous current are shown in Fig. 11.17. The motor is connected to supply through Th1D2 for the period $\alpha < \omega t < \pi$. Beyond π , the motor is shorted through the free-wheeling diode DFW. The armature current decays to zero at angle β (extinction angle) $\pi + \alpha$, i.e., before the thyristor Th2 is fired, thereby making the armature current discontinuous. During α to π , the conduction period through Th1D2, the motor terminal voltage is the same as the input voltage. During π to β the motor terminal voltage is zero as motor terminals are shorted by the free-wheeling diode. From β to $\pi + \alpha$, the motor coasts and so its terminal voltage is the same as its induced emf.

Full-Converter feeding a Separately Excited DC Motor:

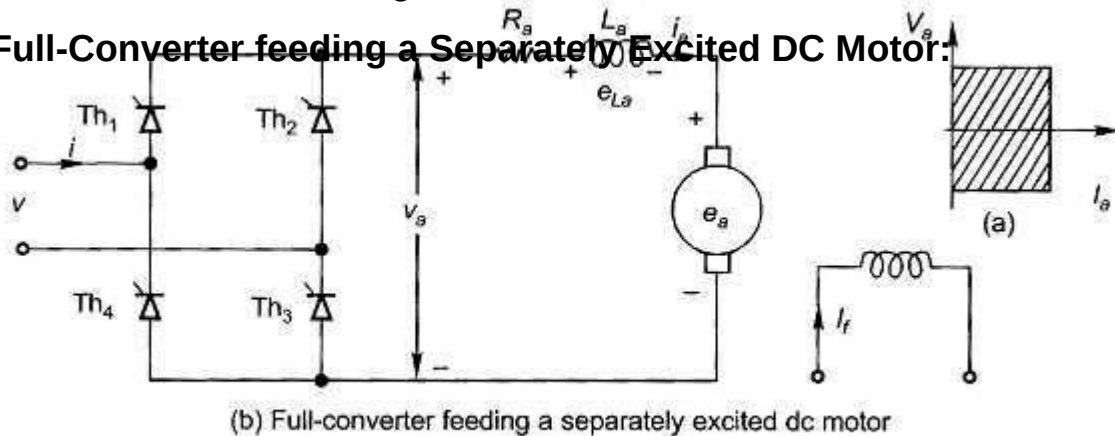

Fig. 11.18

A full-converter is a two-quadrant converter (see Fig. 11.18(a)) in which the voltage polarity of the output can reverse, but the current remains unidirectional because of the unidirectional thyristors. A full-converter employs four thyristors but no free-wheeling diode is required. A full-converter feeding a separately excited DC Motor Control is shown in Fig. 11.18. The voltage and current waveforms are shown in Fig. 11.19 with the assumption that the armature current i_a is almost constant. Thyristors Th1 Th3 conduct for the interval $\alpha < \omega t < \pi + \alpha$ and connect the motor to supply. At $\pi + \alpha$, thyristors Th2Th4 are triggered. Immediately the supply voltage appears in reverse-bias across Th1 Th3 and turns them off. This is **natural** or **line commutation**. The motor current is transferred from Th1 Th3 to Th2Th4. Since there is no period when the motor is disconnected from supply, no free-wheeling is necessary. During α to π , energy flows from the supply to motor (both v and i are positive and so are v_a and i_a).

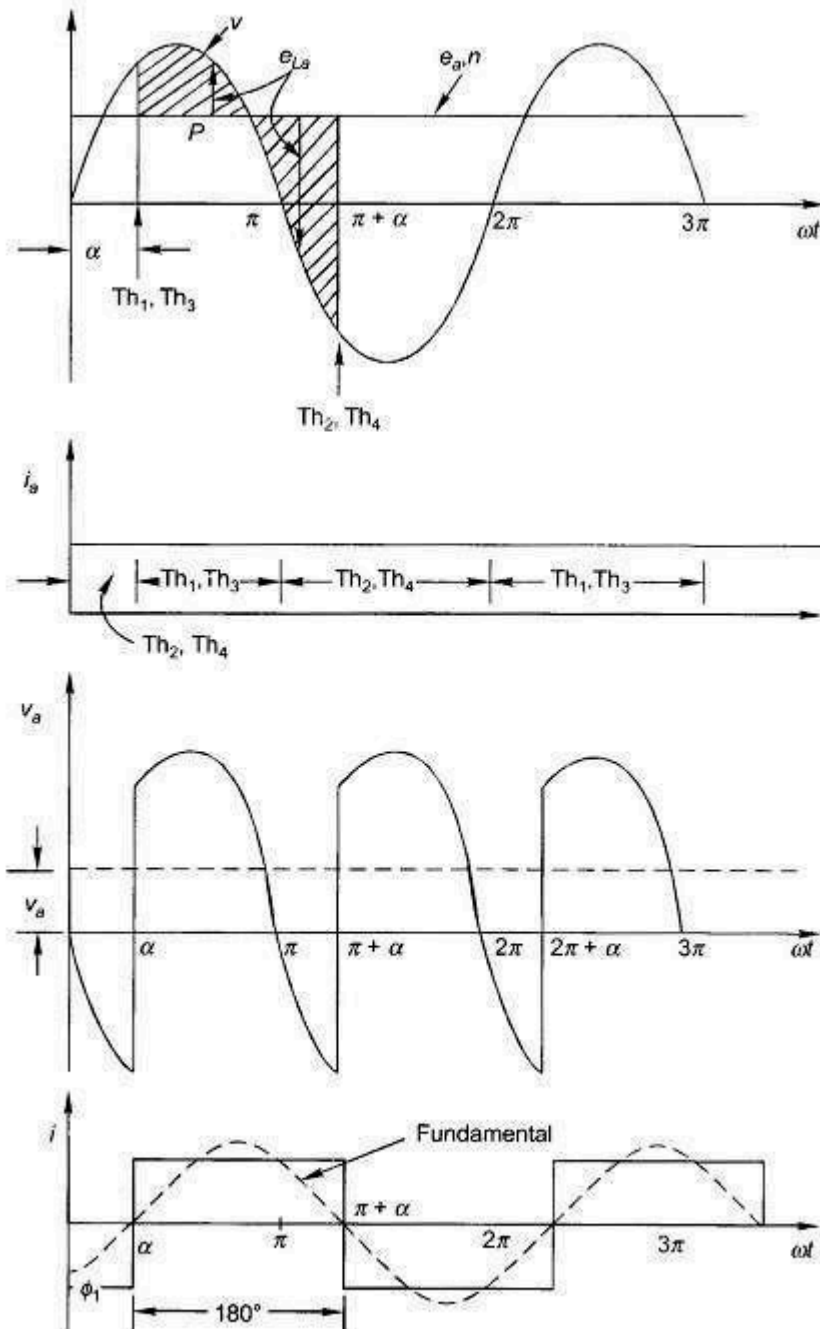

Fig 11.19 Voltage and current waveforms of full-converter feeding separately excited dc motor, continuous armature current (almost constant); $\alpha < 90^\circ$

However, during π to $\pi + \alpha$, some of the motor energy is fed back to the supply (v and i have opposite polarity and so are v_a and i_a which means reversal of power flow). Observe that the fundamental of the current drawn from the mains lags the voltage by angle $\phi_1 = \alpha$.

The voltage and current waveforms for $\alpha > 90^\circ$ are shown in Fig. 11.20.

The

average motor terminal voltage is now negative. If the motor terminals are reversed, it will act as a generator feeding power back to the ac supply.

This is

the motor. One point needs to be noted here. During the conduction period of either Th1Th3 or Th2Th4 as the supply voltage becomes negative, the armature current begins to reduce, causing the inductance polarity to reverse so that the conducting thyristors continue to be forward-biased.

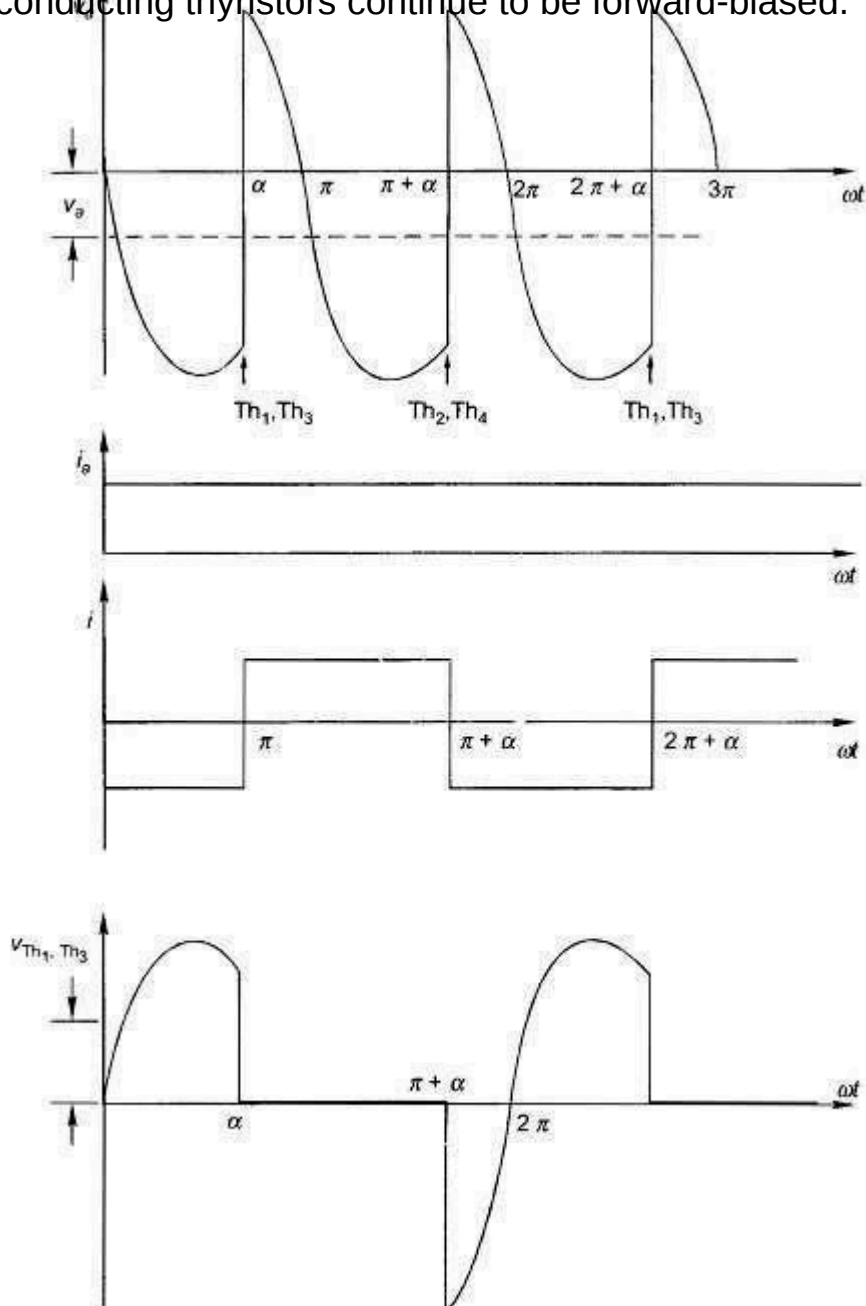

Fig. 11.20 Voltage and current waveforms for full converter; $\alpha > 90^\circ$

The voltage and current waveforms for the case of discontinuous armature current can be found as in the case of the semi-converter. (see Fig. 11.20).

Torque-Speed Characteristics:

It will be assumed here that the armature current is continuous. For a semi converter with free-wheeling diode action, the armature circuit equations are

$$v_a = v = R_a i_a + L_a \frac{di_a}{dt} + e_a \quad \alpha < \omega t < \pi \quad (11.2)$$

$$v_a = 0 = R_a i_a + L_a \frac{di_a}{dt} + e_a \quad \pi < \omega t < \pi + \alpha \quad (11.3)$$

For a full-converter, the armature circuit equation is

$$v_a = v = R_a i_a + L_a \frac{di_a}{dt} + e_a \quad \alpha < \omega t < \pi + \alpha \quad (11.4)$$

Let $v = \sqrt{2} V \sin \omega t$. The average motor terminal voltages are: With a semi-converter,

$$V_a = \frac{1}{\pi} \int_{\alpha}^{\pi} \sqrt{2} V \sin \omega t d(\omega t) = \frac{\sqrt{2} V}{\pi} (1 + \cos \alpha) \quad (11.5)$$

With a full-converter,

$$V_a = \frac{1}{\pi} \int_{\alpha}^{\pi + \alpha} \sqrt{2} V \sin \omega t d(\omega t) = \frac{2\sqrt{2} V}{\pi} \cos \alpha \quad (11.6)$$

Figure 11.21 gives the variation of the motor terminal voltage as a function of the firing angle for both the semi-converter and full-converter. In the case of the full-converter inversion operation occurs for $90^\circ < \alpha < 180^\circ$.

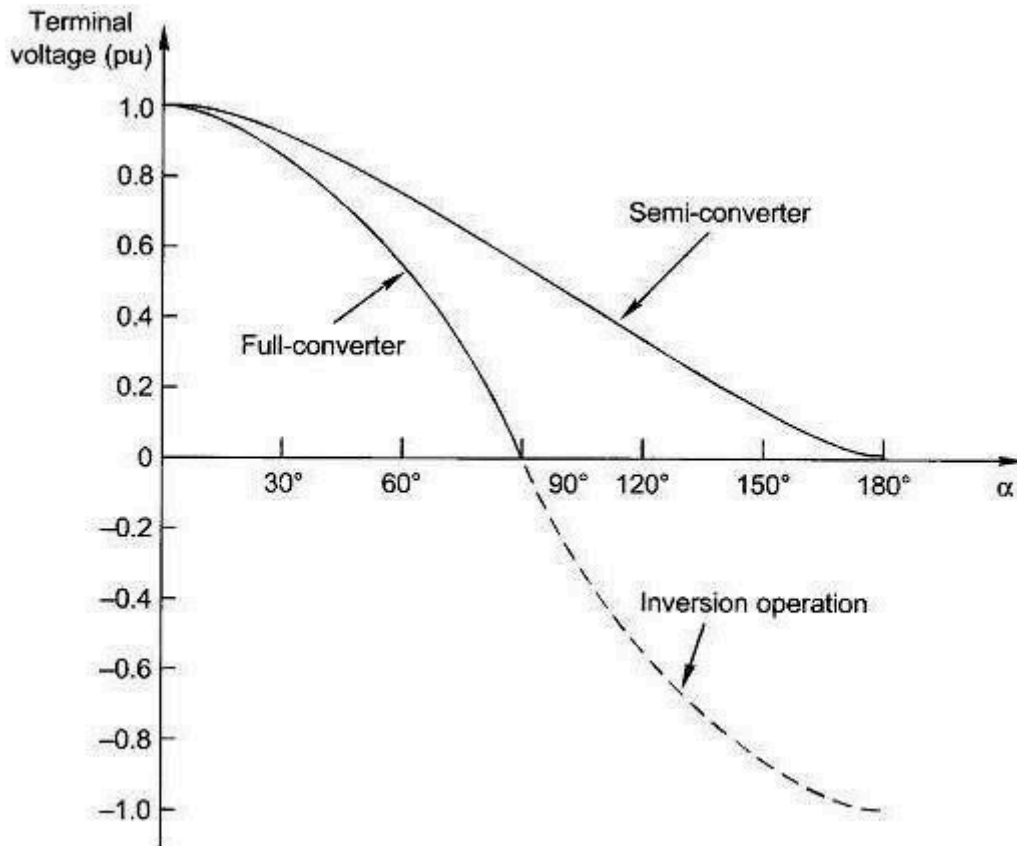

Fig. 11.21 Variation of the converter terminal voltage with firing angle

The motor equations for average values are

$$E_a = K_a \Phi n \quad (11.7)$$

$$T = K_a \Phi I_a \quad (11.8)$$

and

$$n = \frac{V_a - I_a R_a}{K_a \Phi} \quad (11.9)$$

Substituting for I_a from Eq. (11.8) and V_a from Eqs (11.5) or (11.6) in Eq. (11.9), the speed-torque characteristics are given as follows:

With a semi-converter,

$$n = \frac{(\sqrt{2}V/\pi)(1 + \cos \alpha)}{K_a \Phi} - \frac{R_a}{(K_a \Phi)^2} T \quad (11.10)$$

With a full-converter

$$n = \frac{2\sqrt{2}V \cos \alpha}{K_a \Phi} - \frac{R_a}{(K_a \Phi)^2} T \quad (11.11)$$

The first term in Eqs. (11.10) and (11.11) represents the theoretical no-load speed while the second term represents speed drop caused by armature resistance. The theoretical no-load speed can be varied by the firing angle α .

In the case of discontinuous current, the average voltage at motor terminals depends upon the angle β (extinction angle) which itself is dependent on the

average motor speed n , average motor current I_a and firing angle α . The analytical treatment of this case is beyond the scope of this book.

Dual-Converter:

The dual-converter can operate in all the four quadrants as shown in Fig. 11.22(a). Its circuit is shown in Fig. 11.22(b). It is indeed two full-converting to dc in either direction. The dual converter provides virtually instantaneous reversal of voltage at dc terminals.

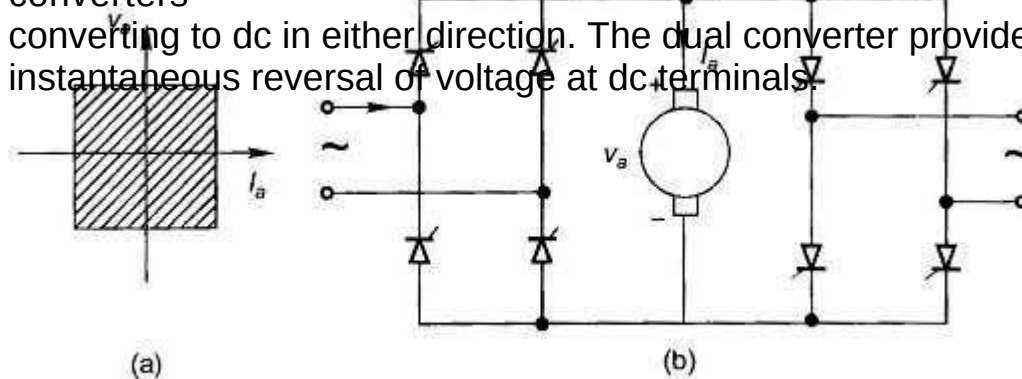

Fig. 11.22

Control of DC Series Motor: Semi-converters and full-converters are also

employed for control of a dc series

motor. The total circuit inductance is high because of the series field, consequence of which the armature current is mostly continuous. The

governing

motor equations differ as the flux/pole is now proportional to the

armature current. The treatment otherwise is similar to that of a separately

excited DC

Motor Control and will not be pursued here for want of space.

DC Motor Speed Control using Chopper

In many different applications it is required to control speed of DC motor. Some of the examples are

- In treadmill machine it is required to vary the speed of motor that used to roll the belt
- The speed of DC motor used in railway engines (traction) has to be varied
- E-bikes, e-bicycles, e-scooters also runs on DC motor and to vary their speed it is required to control speed of DC motor
- DC motors are also used in portable sewing machine, drill machine etc, in which speed control of motor is provided for different operation

One of the popular methods of speed control of DC motor is using chopper. *Chopper is a device that gives variable DC output from applied fixed DC input.* It simply chops fixed DC and generates variable DC. Let us first understand how it generates variable DC.

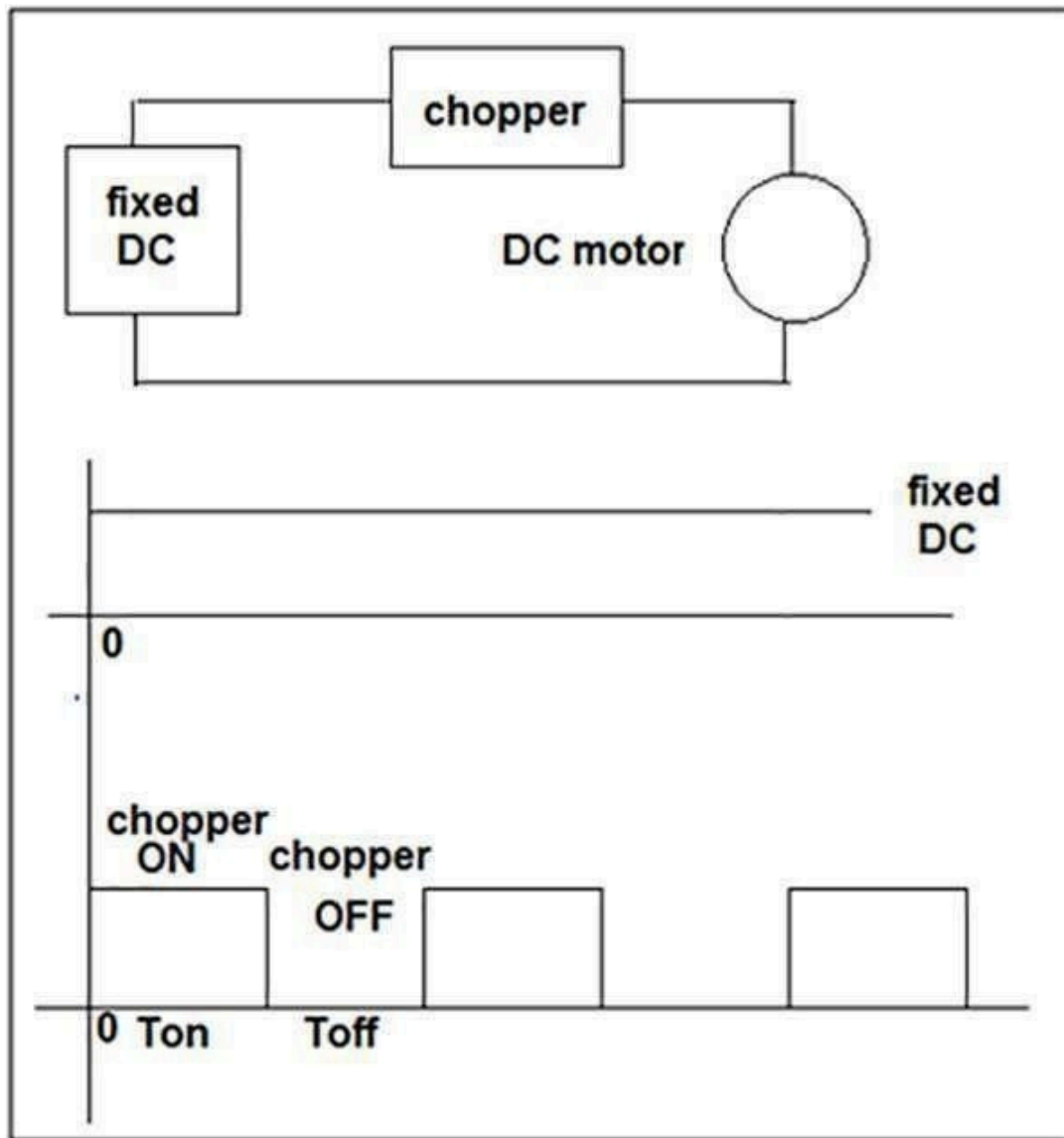

Fig. 1: Block Representation of Chopper circuit used to control rotation of DC Motor

As shown in figure the chopper supplies fixed DC voltage to motor. When chopper is ON motor gets supply but when chopper is off motor does not get the supply. So as shown in figure let us say chopper is on for T_{on} time and it is off for T_{off} time. So depending upon the T_{on} and T_{off} time the DC voltage applied to motor is

$$V_{dc} = [T_{on} / (T_{on} + T_{off})] \times V_{fixed}$$

But

$$T_{on} + T_{off} = T_{total}$$

So

$$V_{dc} = [T_{on} / T_{total}] \times V_{fixed}$$

Here T_{on} / T_{total} is called duty cycle. So as duty cycle is more the average DC voltage supplied to motor is more and so speed of motor is increased. So as duty cycle is varied by varying on and off time of chopper, the speed of motor can be varied. The given circuit demonstrates one of such chopper circuit using Zero Cross Detector (ZCD), timer IC NE555 and darlington amplifier TIP122 used as chopper device. The circuit chops rectified DC output and varies the speed of DC motor.

Circuit Description

- 230V @ 50 Hz AC is applied at the primary of transformer T1 (0-12 VAC, 500 mA). Its secondary is connected with AC input terminals of bridge rectifier BR1.
- Rectified output is given to base of transistor Q1 through voltage divider formed by resistors R1 (1K) & R2 (1K).
- Collector output of Q1 is fed to base of transistor Q2 through R4 (470Ω). Q1 and Q2 both are connected in switch configuration as shown.
- The output of Q2 is applied at the trigger input of NE555 chip U1. It is configured in monostable mode. Timing components RV1 (10K pot) and C1 (1 μF) decides width of output pulse
- Output of U1 is applied to base of darlington transistor TIP122 through current limiting resistor R6
- The DC motor is connected between rectified output and collector of TIP122. The emitter of TIP122 is connected to ground
(Check the circuit diagram below for complete circuit for DC motor speed control using chopper)

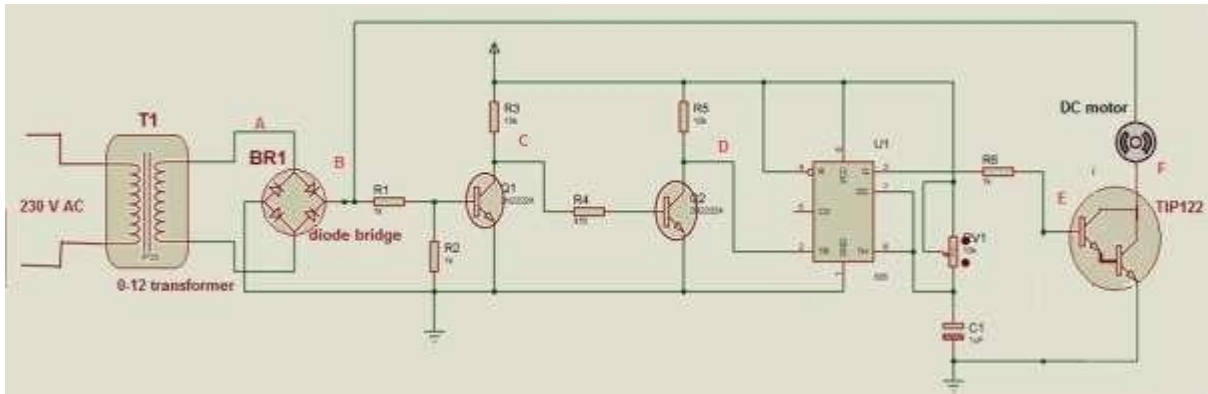

Circuit Operation

Let us understand the circuit operation with the help of waveforms at different points A, B, C, D, E and F

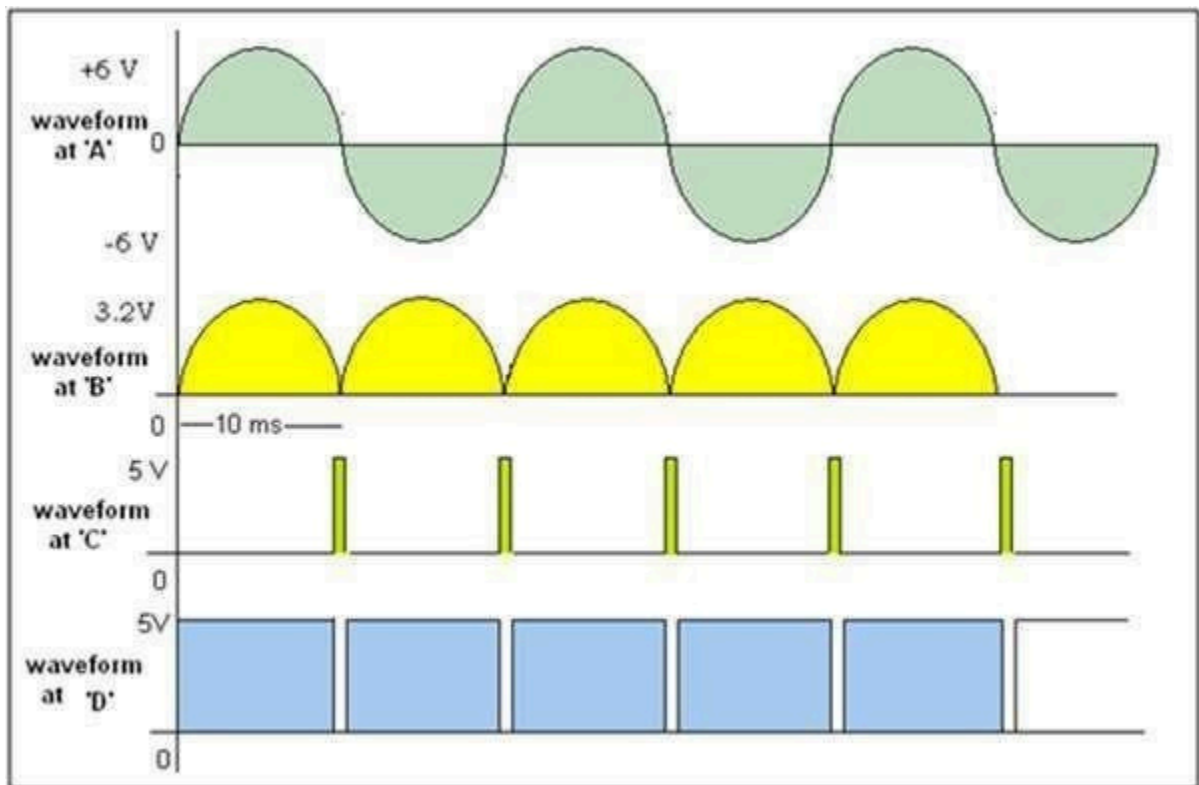

Fig. 2: Timing Diagram of Signals at various stages of the chopper circuit

- Step down transformer T1 steps down 230 VAC into 12 VAC as shown as waveform 1 above figure at point A

- This AC input is given to bridge rectifier. Bridge rectifier will produce rectified DC output as shown in second waveform if above figure at point B
- This rectified output is given to base of transistor Q1. Because transistor Q1 is connected in switch configuration, when the input at the base becomes lower than 0.7 V it comes into cutoff and produces very short duration positive pulse at point 'C'. That is shown as 3rd waveform in figure
- As these positive pulses are given to Q2 which is again connected in switch configuration, it will produce negative pulse at point 'D' of same width of positive pulse. This is shown as 4th waveform
- These negative pulses are applied to trigger input of NE555 chip connected in monostable mode. So, it will generate high output every time when it gets this negative pulse. Its time period can be varied from 0 milisecond to max 10 milisecond using 10 K pot
- As per the waveforms given in below figure let us understand 2 different cases with pulse width of NE555 3 ms and 8 ms
- As shown a second waveform in above figure, the NE555 will generate high output when gets negative pulse at its trigger input. For first case the width of pulse is 3 ms
- Because this pulse is given to base input of TIP122, it is turned ON till pulse is high. When TIP122 is ON the motor gets chopped rectified output as shown in 3rd waveform in figure. Out of total 10 ms time, the motor gets DC waveform for 3 ms only
- So average voltage applied to DC motor is less (as shown in waveform) and its speed is also less

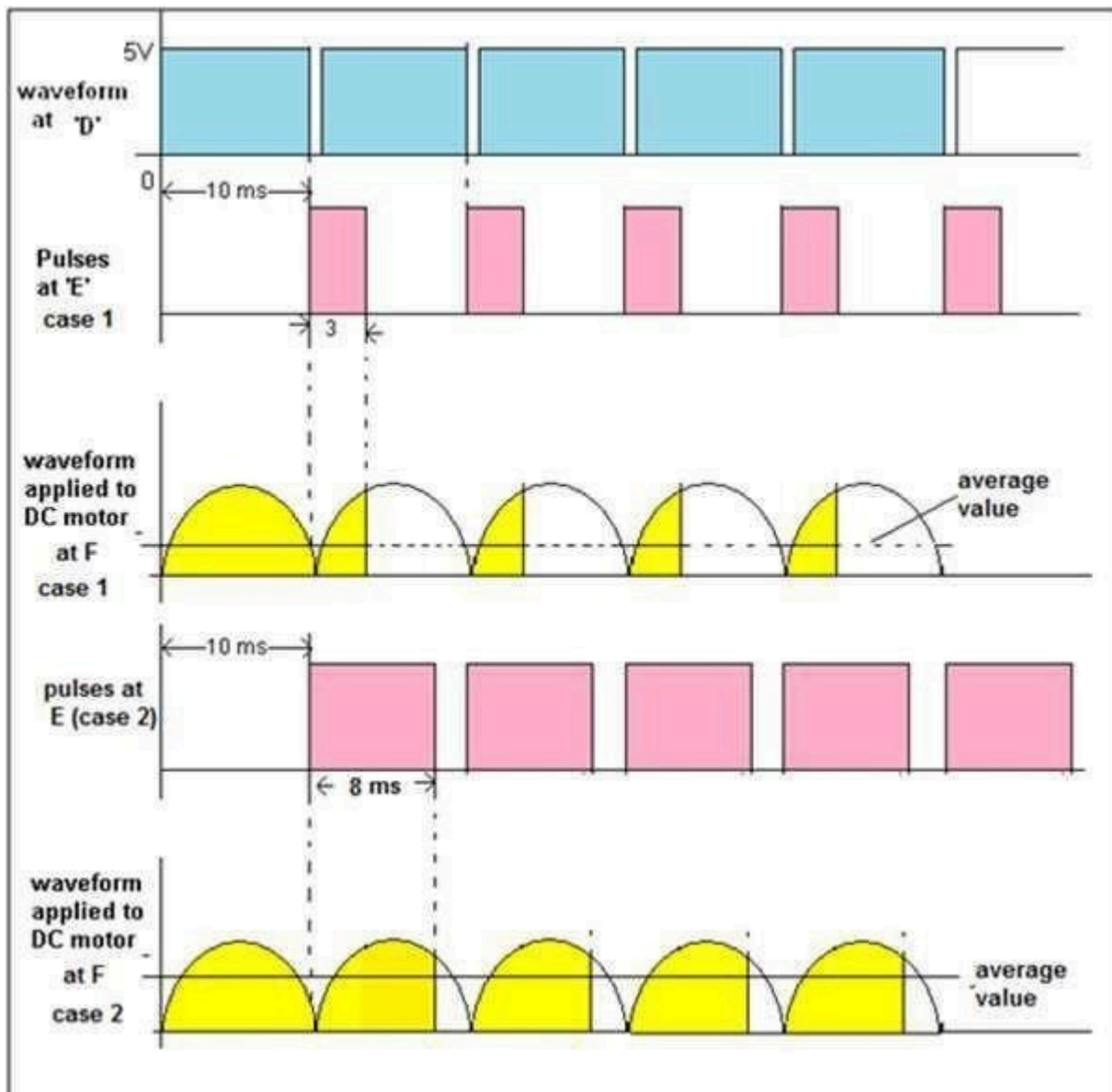

Fig. 3: Timing Diagram of Output Waveforms from the Chopper Circuit

As shown in 4th and 5th waveforms, now the time period (pulse width) of NE555 is increased to 8 ms. So, the rectified output applied to DC motor is also more – means average voltage applied to motor is more and its speed is more

Thus, as time period (width of output pulse) of NE555 is varied from 0 ms to 10 ms, it gives chopped rectified DC wave to motor that will vary its speed from min to max.

List the factors affecting speed of the AC motors

A three phase induction motor is basically a constant speed motor so it's somewhat difficult to control its speed. The speed control of induction motor is done at the cost of decrease in efficiency and low electrical power factor.

Before discussing the methods to **control the speed of three phase induction motor** one should know the basic formulas of speed and torque of three phase induction motor as the methods of speed control depends upon these formulas.

Synchronous Speed

$$N_s = \frac{120f}{P}$$

Where, f = frequency and P is the number of poles

The speed of induction motor is given by,

$$N = N_s(1 - s)$$

Where,

N is the speed of the rotor of an induction motor,

Ns is the synchronous speed,

S is the slip.

The torque produced by three phase induction motor is given by,

$$T = \frac{3}{2\pi N_s} X \frac{sE_2^2 R_2}{R_2^2 + (sX_2)^2}$$

When the rotor is at standstill slip, s is one.

So the equation of torque is,

$$T = \frac{3}{2\pi N_s} X \frac{E_2^2 R_2}{R_2^2 + X_2^2}$$

Where,

E2 is the rotor emf

Ns is the synchronous speed

R2 is the rotor resistance

X2 is the rotor inductive reactance

The Speed of Induction Motor is changed from Both Stator and Rotor Side. The speed control of three phase induction motor from stator side are further classified as:

- V / f control or frequency control.
- Changing the number of stator poles.
- Controlling supply voltage.
- Adding rheostat in the stator circuit.

The speed controls of three phase induction motor from rotor side are further classified as:

- Adding external resistance on rotor side.
- Cascade control method.

- Injecting slip frequency emf into rotor side.

Speed Control from Stator Side:

V / f Control or Frequency Control:

Whenever three phase supply is given to three phase induction motor rotating magnetic field is produced which rotates at synchronous speed given by

$$N_s = \frac{120f}{P}$$

In three phase induction motor emf is induced by induction similar to that of transformer which is given by

$$E \text{ or } V = 4.44\phi K.T.f \text{ or } \phi = \frac{V}{4.44KTf}$$

Where, K is the winding constant, T is the number of turns per phase and f is frequency. Now if we change frequency synchronous speed changes but with decrease in frequency flux will increase and this change in value of flux causes saturation of rotor and stator cores which will further cause increase in no load current of the motor. So, its important to maintain flux, ϕ constant and it is only possible if we change voltage. i.e if we decrease frequency flux increases but at the same time if we decrease voltage flux will also decrease causing no change in flux and hence it remains constant. So, here we are keeping the ratio of V/f as constant. Hence its name is V/ f method. For controlling the speed of three phase induction motor by V/f method we have to supply variable voltage and frequency which is easily obtained by using converter and inverter set.

Controlling Supply Voltage:

The torque produced by running three phase induction motor is given by

$$T \propto \frac{sE_2^2 R_2}{R_2^2 + (sX_2)^2}$$

In low slip region (sX)² is very very small as compared to R₂. So, it can be neglected. So torque becomes

$$T \propto \frac{sE_2^2}{R_2}$$

Since rotor resistance, R₂ is constant so the equation of torque further reduces to

$$T \propto sE_2^2$$

We know that rotor induced emf E₂ a V. So, T a sV².

The equation above clears that if we decrease supply voltage torque will also decrease. But for supplying the same load, the torque must remain the same, and it is only possible if we increase the slip and if the slip increases the motor will run at a reduced speed. This method of speed control is rarely used because a small change in speed requires a large reduction in voltage, and hence the

current drawn by motor increases, which cause overheating of the induction motor.

Changing the number of stator poles:

The stator poles can be changed by two methods

(I) Multiple stator winding method.

(II) Pole amplitude modulation method (PAM)

Multiple Stator Winding Method:

In this method of speed control of three phase induction motor, we provide two separate windings in the stator. These two stator windings are electrically isolated from each other and are wound for two different numbers of poles. Using a switching arrangement, at a time, supply is given to one winding only and hence speed control is possible. Disadvantages of this method are that the smooth speed control is not possible. This method is more costly and less efficient as two different stator windings are required. This method of speed control can only be applied to squirrel cage motor.

Pole Amplitude Modulation Method (PAM):

In this method of speed control of three phase induction motor the original sinusoidal mmf wave is modulated by another sinusoidal mmf wave having the different number of poles.

Let $f_1(\theta)$ be the original mmf wave of induction motor whose speed is to be controlled.

$f_2(\theta)$ be the modulation mmf wave.

P_1 be the number of poles of induction motor whose speed is to be controlled.

P_2 be the number of poles of modulation wave.

$$f_1(\theta) = F_1 \sin \frac{P_1 \theta}{2}$$

$$f_2(\theta) = F_2 \sin \frac{P_2 \theta}{2}$$

After modulation resultant mmf wave

$$F_r(\theta) = F_1 F_2 \sin \frac{P_1 \theta}{2} \sin \frac{P_2 \theta}{2}$$

Apply formula for $2 \sin A \sin B = \cos \frac{A - B}{2} - \cos \frac{A + B}{2}$

So we get, resultant mmf wave

$$F_r(\theta) = F_1 F_2 \frac{\cos \frac{(P_1 - P_2)\theta}{2} - \cos \frac{(P_1 + P_2)\theta}{2}}{2}$$

Therefore the resultant mmf wave will have two different number of poles

i.e $P_{11} = P_1 - P_2$ and $P_{12} = P_1 + P_2$

Therefore by changing the number of poles we can easily change the speed of three phase induction motor.

□ Adding Rheostat in Stator Circuit

In this method of speed control of three phase induction motor rheostat is added in the stator circuit due to this voltage gets dropped. In case of three phase induction motor torque produced is given by $T \propto \frac{V^2}{R}$. If we decrease supply voltage torque will also decrease. But for supplying the same load, the torque must remain the same and it is only possible if we increase the slip and if the slip increase motor will run reduced speed.

Speed Control from Rotor Side:

□ Adding External Resistance on Rotor Side

In this method of speed control of three phase induction motor external resistance are added on rotor side. The equation of torque for three phase induction motor is

$$T \propto \frac{s E_2^2 R_2}{R_2^2 + (s X_2)^2}$$

The three-phase induction motor operates in a low slip region. In low slip region term $(sX)^2$ becomes very very small as compared to R_2 . So, it can be neglected. and also E_2 is constant. So the equation of torque after simplification becomes,

$$T \propto \frac{1}{R_2}$$

Now if we increase rotor resistance, R_2 torque decreases but to supply the same load torque must remain constant. So, we increase slip, which will further result in the decrease in rotor speed. Thus, by adding additional resistance in the rotor circuit, we can decrease the speed of the three-phase induction motor. The main advantage of this method is that with an addition of external resistance

starting torque increases but this method of speed control of three phase induction motor also suffers from some disadvantages:

- The speed above the normal value is not possible.
- Large speed change requires a large value of resistance, and if such large value of resistance is added in the circuit, it will cause large copper loss and hence reduction in efficiency.
- Presence of resistance causes more losses.
- This method cannot be used for squirrel cage induction motor.

□ **Cascade Control Method**

In this method of speed control of three phase induction motor, the two three-phase induction motors are connected on a common shaft and hence called cascaded motor. One motor is called the main motor, and another motor is called the auxiliary motor. The three-phase supply is given to the stator of the main motor while the auxiliary motor is derived at a slip frequency from the slip ring of the main motor.

Let N_{S1} be the synchronous speed of the main motor.

N_{S2} be the synchronous speed of the auxiliary motor.

P_1 be the number of poles of the main motor.

P_2 be the number of poles of the auxiliary motor.

F is the supply frequency.

F_1 is the frequency of rotor induced emf of the main motor.

N is the speed of set, and it remains same for both the main and auxiliary motor as both the motors are mounted on the common shaft.

S_1 is the slip of main motor.

$$S_1 = \frac{N_{S1} - N}{N_{S1}}$$

$$F_1 = S_1 F$$

The auxiliary motor is supplied with same frequency as the main motor i.e

$$F_1 = F_2$$

$$N_{S2} = \frac{120F_2}{P_2} = \frac{120F_1}{P_2}$$

$$N_{S2} = \frac{120S_1 F}{P_2}$$

Now put the value of

$$S_1 = \frac{N_{S1} - N}{N_{S1}}$$

$$\text{We get, } N_{S2} = \frac{120F(N_{S1} - N)}{P_2 N_{S1}}$$

Now at no load, the speed of auxiliary rotor is almost same as its synchronous speed i.e $N = N_{S2}$

$$N = \frac{120F(N_{S1} - N)}{P_2 N_{S1}}$$

Now rearrange the above equation and find out the value of N, we get,

$$N = \frac{120F}{P_1 - P_2}$$

This cascaded set of two motors will now run at new speed having number of poles $(P_1 + P_2)$. In the above method the torque produced by the main and auxiliary motor will act in same direction, resulting in number of poles $(P_1 + P_2)$. Such type of cascading is called cumulative cascading. There is one more type of cascading in which the torque produced by the main motor is in opposite direction to that of auxiliary motor. Such type of cascading is called differential cascading; resulting in speed corresponds to number of poles $(P_1 - P_2)$.

In this method of speed control of three phase induction motor, four different speeds can be obtained

- When only main induction motor work, having speed corresponds to .
- When only auxiliary induction motor work, having speed corresponds to .
- When cumulative cascading is done, then the complete set runs at a speed of .
- When differential cascading is done, then the complete set runs at a speed of .
- **Injecting Slip Frequency EMF into Rotor Side**

When the speed control of three phase induction motor is done by adding resistance in rotor circuit, some part of power called, the slip power is lost as I^2R losses. Therefore the efficiency of three phase induction motor is reduced by this method of speed control. This slip power loss can be recovered and supplied back to improve the overall efficiency of the three-phase induction motor, and this scheme of recovering the power is called slip power

recovery scheme and this is done by connecting an external source of emf of slip frequency to the rotor circuit. The injected emf can either oppose the rotor induced emf or aids the rotor induced emf. If it opposes the rotor induced emf, the total rotor resistance increases and hence the speed is decreased and if the injected emf aids the main rotor emf the total decreases and hence speed increases. Therefore by injecting induced emf in the rotor circuit, the speed can be easily controlled. The main advantage of this type of speed control of three phase induction motor is that a wide range of speed control is possible whether it is above normal or below normal speed.

List of The factors affecting speed of AC motor →
The speed of an Induction motor is given by

$$N_r = (1-s) N_s \quad \& \quad N_s = \frac{120f}{P}$$

$$\Rightarrow N_r = \frac{(1-s) \times 120f}{P} \quad \text{--- ①}$$

From equation 1, we can varied the speed of an IM by varying frequency and no. of poles of an IM. Another so many methods are also present to control the speed of IM such methods are given by,

- ① Pole changing
- ② stator voltage control
- ③ supply frequency control
- ④ Rotor resistance control
- ⑤ slip energy recovery control

But from the above methods there are two methods like frequency control and voltage control methods are generally used.

For synchronous motor :

$$N_s = \frac{120f}{P} \quad \text{--- ②}$$

common method to control the speed of the synchronous motor is supply frequency control method.

Speed control of Induction Motor by using AC voltage controller :-

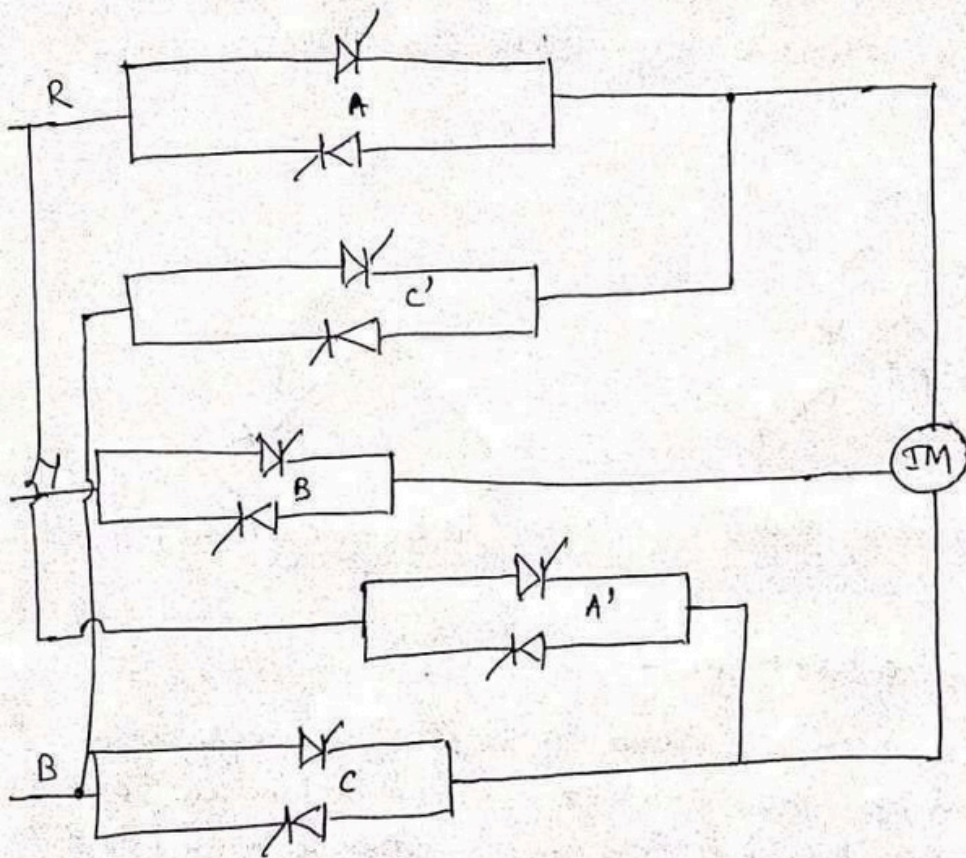

Here Four quadrant operation with plugging is obtained by the using of the circuit given above.

Thyristor Pairs A, B, C provide operation in quadrant I and IV where as

A', B', C' thyristor pair provides operation in quadrant II and III

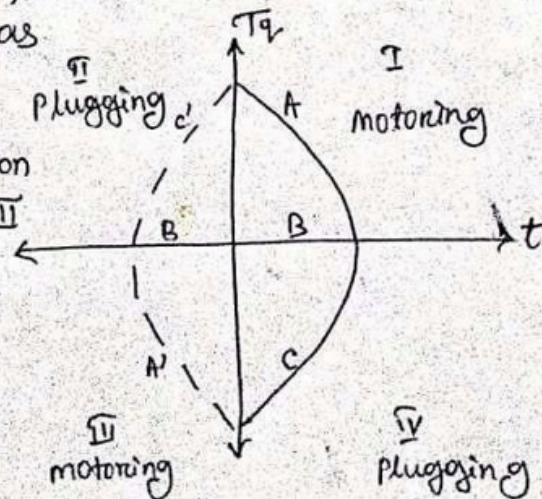

operation:-

while changing from one set of thyristor pairs to another, that is from ABC to A'BC' and viceversa, there should be taken to ensure that the incoming pair is activated only after the outgoing pair is fully turned off.

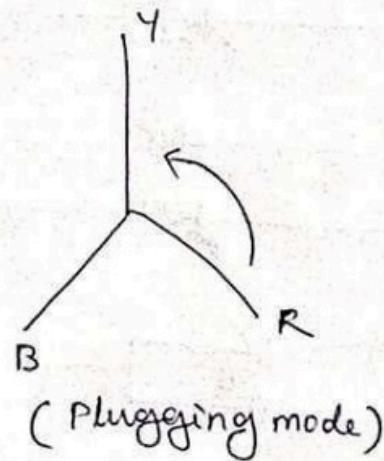
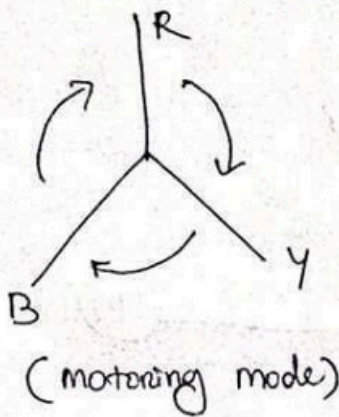

Some disadvantages:-

- (i) output voltage depends on both delay angle and period of the current flow, which are directed by load power factor that's why if load changes then the output voltage of the controller changes continuously.
- (ii) Due to fluctuating the voltage and current then the harmonics are present which may cause eddy current in the core which causes the overheat of the IM.

12.8. SPEED CONTROL OF THREE-PHASE INDUCTION MOTORS

Three-phase induction motors are admirably suited to fulfil the demand of loads requiring substantially a constant speed. Several industrial applications, however, need adjustable speeds for their efficient operation. The object of the present section is to describe the basic principles of speed control techniques employed to three-phase induction motors through the use of power-electronics converters. The various methods of speed control through semiconductor devices are as under :

- (i) Stator voltage control
- (ii) Stator frequency control
- (iii) Stator voltage and frequency control
- (iv) Stator current control
- (v) Static rotor-resistance control
- (vi) Slip-energy recovery control.

Methods (i) to (iv) are applicable to both SCIMs and WRIMs whereas methods (v) and (vi) can be used for WRIMs only. These methods are now described in what follows.

12.8.1. Stator Voltage Control

It is seen from Eq. (12.50) that motor torque T_e is proportional to the square of the stator supply voltage. A reduction in the supply voltage will reduce the motor torque and therefore the speed of the drive. If the motor terminal voltage is reduced to KV_1 where $K < 1$, then the motor torque is given by

$$T_e = \frac{3}{\omega_s} \cdot \frac{(KV_1)^2}{\left(r_1 + \frac{r_2}{s}\right)^2 + (x_1 + x_2)^2} \cdot \frac{r_2}{s} \quad \dots(12.61)$$

For the purpose of varying the voltage applied to a 3-phase induction motor so as to achieve a speed control, a 3-phase ac voltage controller is usually employed. Fig. 12.27 (a) shows a three-phase ac voltage controller feeding a three-phase induction motor. By controlling the firing angle of the thyristors connected in antiparallel in each phase, the rms value of the stator voltage can be regulated. As a consequence, motor torque and thus speed of the drive is controlled. In Fig. 12.27 (b), for load torque T_L , a is the operating point at rated

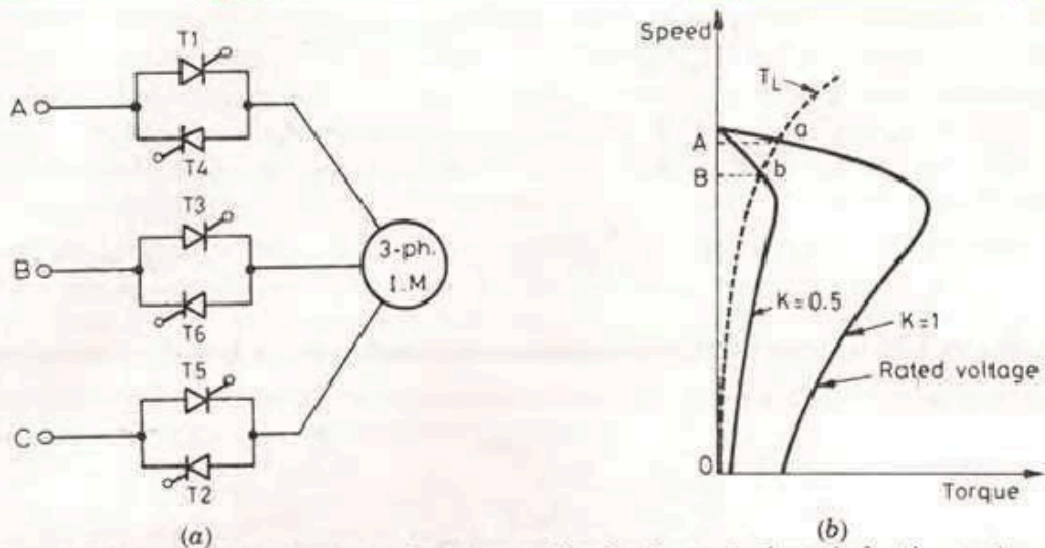

Fig. 12.27. (a) Three-phase ac voltage controller feeding a 3-phase induction motor
 (b) Speed-torque characteristics as effected by stator voltage control.

voltage and OA is the motor speed. For reduced stator voltage ($K = 0.5$), b is the operating point and OB is the reduced motor speed for load torque T_L . This method is suitable for motors having large value of s_m . For low-slip motors, the range of speed control is very narrow.

Stator-voltage-control method offers limited speed range. It is usual to use 3-phase voltage controllers. Their use, however, introduces pronounced harmonic contents and input supply power factor for the voltage controller is quite low. These are, therefore, used for low-power drives like fans, blowers and centrifugal pumps requiring low starting torque. For these types of loads, the load torque is proportional to speed squared and input current is maximum when slip $s = 1/3$, this is proved in Example 12.22.

12.8.2. Stator Frequency Control

By changing the supply frequency, motor synchronous speed can be altered and thus torque and speed of a 3-phase induction motor can be controlled. For a three-phase induction motor, per-phase supply voltage is $V_1 = \sqrt{2} \pi f_1 N_1 \phi k_w$. This expression shows that under

rated voltage and frequency operation, flux will be rated. In case supply frequency is reduced with constant V_1 , the air-gap flux increases and the induction motor magnetic circuit gets saturated. The motor parameters will change leading to inaccurate speed-torque characteristics. Further, at low frequencies, reactances will be low leading to high motor currents, more losses and reduced efficiency. In view of this, induction motor (I.M.) speed control with constant supply voltage and reduced supply frequency is rarely used in practice.

With constant supply voltage, if the supply frequency is increased, the synchronous speed and therefore motor speed rises. But, with increase in frequency, flux and torque also get reduced. IM performance at constant voltage and increased frequency can be obtained by neglecting X_m and r_1 from the equivalent circuit of Fig. 12.25 (a). This assumption is not going to introduce any noticeable error as magnetizing current at high frequency is quite small. Thus, rotor current under this assumption is given by

$$I_2 = \frac{V_1}{\left[\left(\frac{r_2}{s} \right)^2 + (x_1 + x_2)^2 \right]^{1/2}} \quad \dots(12.62)$$

Synchronous speed, $\omega_s = \frac{4\pi f_1}{P} = \frac{2\omega_1}{P} \text{ rad/s}$

Motor torque,
$$T_e = \frac{3}{\omega_s} \cdot I_2^2 \frac{r_2}{s}$$

$$= \frac{3P}{2\omega_1} \cdot \frac{V_1^2}{\left(\frac{r_2}{s} \right)^2 + (x_1 + x_2)^2} \cdot \frac{r_2}{s} \quad \dots(12.63)$$

Slip, $s = \frac{f_2}{f_1} = \frac{\omega_2}{\omega_1} \text{ or } \omega_2 = s \omega_1$

Here f_2 and ω_2 are the rotor frequencies in Hz and rad/s respectively. Substituting the value of slip $s = \frac{\omega_2}{\omega_1}$ in Eq. (12.63), we get

$$T_e = \frac{3P}{2\omega_1} \cdot \frac{V_1^2 \cdot \omega_1}{\frac{r_2 \cdot \omega_1^2}{\omega_2^2} + \omega_1^2 (l_1 + l_2)} \cdot \frac{r_2}{\omega_2}$$

$$= \frac{3P}{2\omega_1^2} \cdot \frac{V_1^2 \cdot \omega_2}{r_2^2 + \omega_2^2 (l_1 + l_2)^2} \cdot r_2 \quad \dots(12.64)$$

Slip at which maximum torque occurs is obtained from Fig. 12.25 (a) as

$$s_{mt} = \frac{r_2}{x_1 + x_2} \quad \dots(12.65)$$

Rotor frequency in rad/s at which maximum torque occurs is given by

$$\omega_{2m} = s_{mT} \cdot \omega_1 = \frac{\omega_1 \cdot r_2}{\omega_1 (l_1 + l_2)} = \frac{r_2}{l_1 + l_2}$$

Note that ω_{2m} does not depend on the supply frequency ω_1 . Substituting $r_2 = \omega_{2m} \cdot (l_1 + l_2)$ in Eq. (12.64) gives maximum torque $T_{e,m}$ as

$$T_{e.m} = \frac{3P}{2\omega_1^2} \cdot \frac{V_1^2 \cdot \omega_{2m}^2 \cdot (l_1 + l_2)}{\omega_{2m}^2 (l_1 + l_2)^2 + \omega_{2m}^2 (l_1 + l_2)^2}$$

$$= \frac{3P}{2\omega_1^2} \cdot \frac{V_1^2}{l_1 + l_2} \quad \dots(12.66)$$

Eq. (12.66) indicates that T_{em} is inversely proportional to supply-frequency squared. Also,

$$T_{em} \cdot \omega_1^2 = \frac{3P}{2} \cdot \frac{V_1^2}{l_1 + l_2}$$

At given source voltage V_1 , $\frac{3P}{2} \cdot \frac{V_1^2}{l_1 + l_2}$ is constant, therefore, $T_{em} \cdot \omega_1^2$ is also constant. As the operating frequency ω_1 is increased, $T_{em} \cdot \omega_1^2$ remains constant but maximum torque at increased frequency ω_1 gets reduced as shown in Fig. 12.28. Supposing rated frequency for a motor is 50 Hz and $T_{e.m} = 100$ Nm. If the motor is now operated at 100 Hz, then $100 (2\pi \times 50)^2 = (\text{new maximum torque}) (2\pi \times 100)^2$ or the maximum torque at increased frequency of 100 Hz is 25 Nm. Such type of IM behaviour is similar to the working of dc series motors. With constant voltage and increased-frequency operation, air-gap flux gets reduced; therefore, during this control, IM is said to be working in *field-weakening mode*. Constant voltage and variable frequency control of Fig. 12.28 can be obtained by feeding 3-phase IM through three-phase inverters discussed in Chapter 8.

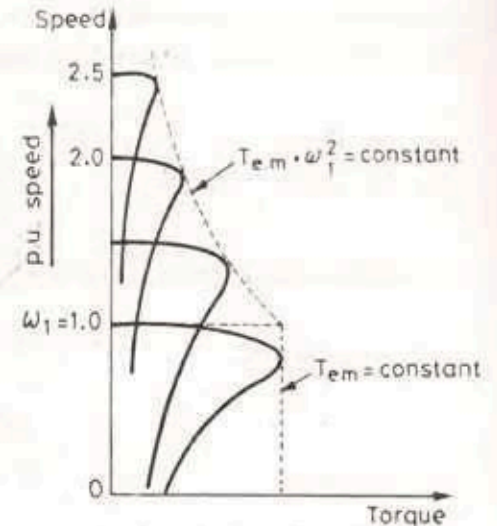

Fig. 12.28. Speed torque characteristics of a 3-phase IM with stator frequency control with constant supply voltage.

12.8.3. Stator Voltage and Frequency Control

For a 3-phase IM, stator voltage per phase is given by

$$V_1 = \sqrt{2} \pi f_1 \cdot N_{ph1} \cdot \phi_1 \cdot k_{\omega 1} \quad \dots(12.66)$$

It is seen from above equation that if the ratio of supply voltage V_1 to supply frequency f_1 is kept constant, the air-gap flux ϕ_1 remains constant. From Fig. 12.25 (b) and Eq. (12.50), the starting torque is given by

$$T_{e.st} = \frac{3}{\omega_s} \cdot \frac{V_1^2}{(r_1 + r_2)^2 + (x_1 + x_2)^2} \cdot r_2$$

As $(r_1 + r_2) \ll (x_1 + x_2)$ and $\omega_s = \frac{2\omega_1}{P}$, we get

$$\begin{aligned} T_{e.st} &= \frac{3P}{2\omega_1} \cdot \frac{V_1^2 \cdot r_2}{\omega_1^2 (l_1 + l_2)^2} \\ &= \frac{3P}{2\omega_1} \cdot \left(\frac{V_1}{\omega_1}\right)^2 \cdot \frac{r_2}{(l_1 + l_2)^2} \end{aligned} \quad \dots(12.67)$$

From Eq. (12.56), maximum torque is given by

$$\begin{aligned} T_{e.m} &= \frac{3}{\omega_s} \cdot \frac{V_1^2}{2(x_1 + x_2)} \\ &= \frac{3P}{2\omega_1} \cdot \frac{V_1^2}{2 \cdot \omega_1 (l_1 + l_2)} \\ &= \frac{3P}{4} \cdot \left(\frac{V_1}{\omega_1}\right)^2 \frac{1}{l_1 + l_2} \end{aligned} \quad \dots(12.68)$$

Eq. (12.68) shows that if V_1/ω_1 , or air-gap flux ϕ_1 , is kept constant, the maximum torque remains unaltered. Eq. (12.67) indicates that starting torque increases even if air-gap flux is kept constant. At low values of frequencies, the effect of resistances cannot be neglected as compared to the reactances. This has the effect of reducing the magnitude of maximum torque at lower frequencies as shown in Fig. 12.29. In practice, at low frequencies, the supply voltage is increased to maintain the level of maximum torque. This method of speed control is also called *volts/hertz* control.

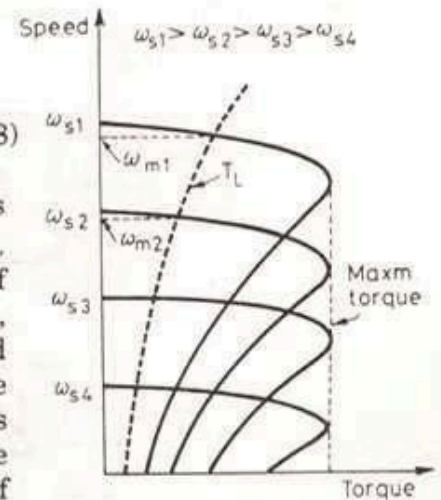

Fig. 12.29. Speed-torque characteristics of a 3-phase IM with volts/hertz control.

If stator resistance is neglected, then from Fig. 12.25 (b), the slip at which maximum torque occurs is given by

$$s_m = \frac{r_2}{x_1 + x_2} = \frac{r_2}{\omega_1 (l_1 + l_2)} \quad \dots(12.69)$$

As the supply frequency ω_1 is reduced, the slip at maximum torque increases.

In Fig. 12.29, load torque T_L for a certain load is also shown. It is seen from this figure that as both voltage and frequency are varied (usually below their rated values), speed of the drive can be controlled. The control of both voltage and frequency can be carried out (so as to keep $\frac{V}{f}$ constant) through the use of three-phase inverters or cycloconverters. Inverters are used in low and medium power drives whereas cycloconverters are suitable for high-power drives like cement mills, locomotives etc.

Variable voltage and variable frequency can be obtained from voltage-source inverters. Four such circuit configurations are shown in Fig. 12.30. In Fig. 12.30 (a), three-phase ac is converted to constant dc by diode rectifier. Voltage and frequency are both varied by PWM inverter. The circuitry between the rectifier and the inverter consists of an inductor L and

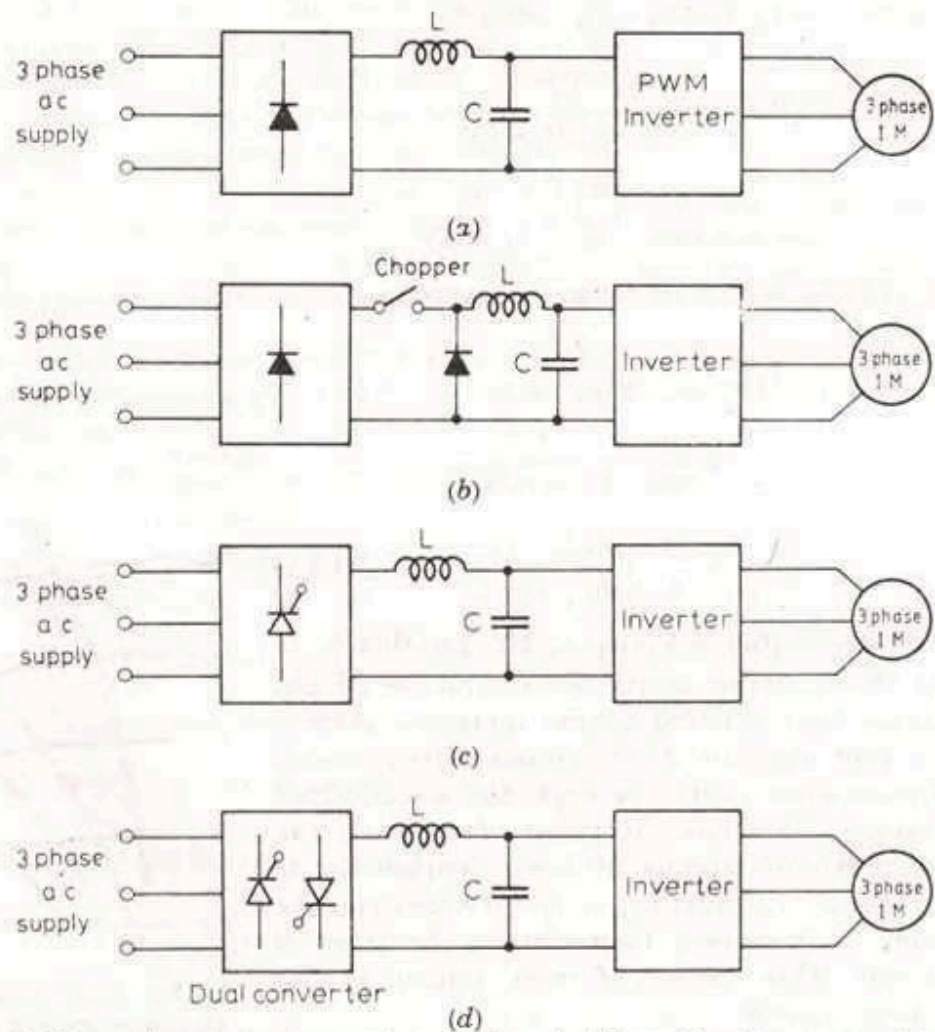

Fig. 12.30. Three-phase induction motor speed control through voltage source inverters.

capacitor C , called filter circuit. The function of filter circuit is to smooth dc input voltage to the inverter. This circuitry in between rectifier and inverter is called *dc link*. In Fig. 12.30 (a), regeneration is not possible because of diode rectifier. Also, inverter would inject harmonics into the 3-phase ac supply.

In Fig. 12.30 (b), three-phase ac is converted to dc by diode rectifier. Chopper varies the dc input voltage to the inverter and frequency is controlled by the inverter. Use of chopper reduces the harmonic injection into the ac supply. Regeneration is not feasible in the scheme of Fig. 12.30 (b).

Fig. 12.30 (c) uses a 3-phase controlled rectifier, dc link consisting of L and C and a force-commutated VSI. Voltage is regulated by controlled rectifier and frequency is varied within the inverter. Here regeneration is possible if three-phase full converter is used. Regeneration is also feasible in the scheme shown in Fig. 12.30 (d). It uses a 3-phase dual converter, L-C filter and inverter. Level of dc input voltage to the inverter is regulated in dual converter whereas frequency is varied within the VSI inverter.

It may be observed from above that volts/hertz control offer speed control from standstill upto rated speed of IM. This method is similar to the armature-voltage control method used for the speed control of a dc motor.

4.8 WORKING OF UPS WITH BLOCK DIAGRAM

There are several applications where even a temporary power failure can cause a great deal of public inconvenience leading to large economic losses. Examples of such applications are major computer installations, process control in chemical plants, safety monitors, general communication systems, hospital intensive care units etc. For such critical loads, it is of paramount importance to provide an uninterruptible power supply (UPS) system so as to maintain the continuity of supply in case of power outages.

Earlier UPS systems were based on an arrangement shown in Fig. 11.7. This scheme is usually called rotating-type UPS. This arrangement consists of DC motor-driven alternator, the shaft of which is also coupled to a diesel engine. The three-phase mains supply, after rectification, charges a dc battery-bank and feeds the dc motor as well. The uninterruptible

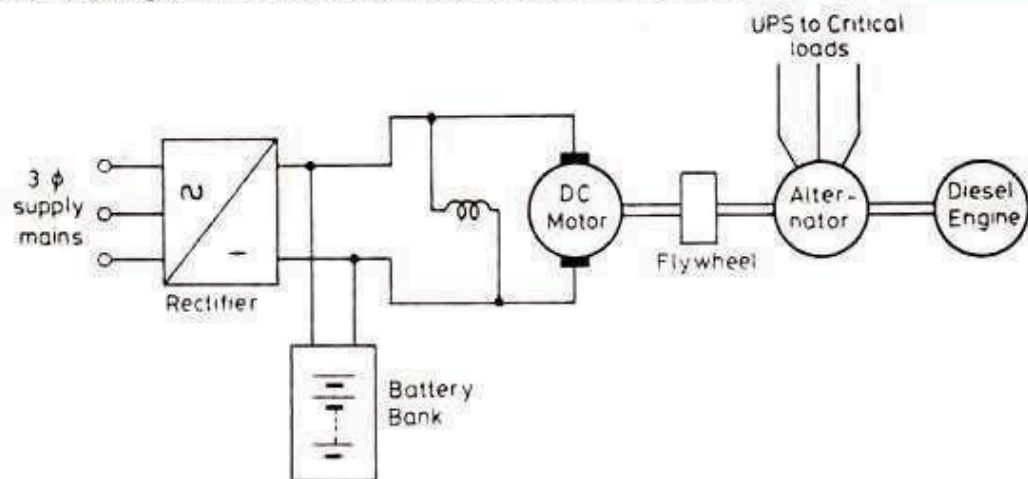

Fig. 11.7. Rotating-type UPS system based on dc motor/alternator set.

power supply needed is taken from the alternator output terminals. When mains supply fails, the diesel engine is run to take over the load. Starting of the diesel engine takes 10 to 15 seconds. During this period, the battery-bank is able to maintain the alternator speed through the dc motor and the flywheel, thus giving a no-break supply to the critical load. At present, however, static UPS systems are becoming popular up to a few kVA ratings.

Static UPS systems are of two types ; namely short-break UPS and no-break UPS. In short-break UPS, the load gets disconnected from the power source for a short duration of the order of 4 to 5 ms. In no-break UPS, load gets continuous uninterrupted supply from the power source. These are now discussed briefly.

Short-break UPS. In situations where short interruption (4 to 5 ms) in supply can be tolerated, the short-break UPS shown in Fig. 11.8 is used. In this system, main ac supply is rectified to dc. This dc output from the rectifier charges the batteries and is also converted

to ac by an inverter, Fig. 11.8. After passing through the filter, ac can be delivered to load in case normally-off contacts are closed. Under normal circumstances, normally-on contacts are closed and normally-off contacts are open and the main supply delivers ac power to the load. At the same time, the rectifier supplies continuous trickle charge to batteries to keep them fully charged. In the event of power outage, normally-off switch is turned-on and the batteries deliver ac power to critical load through the inverter and filter. A momentary interruption in

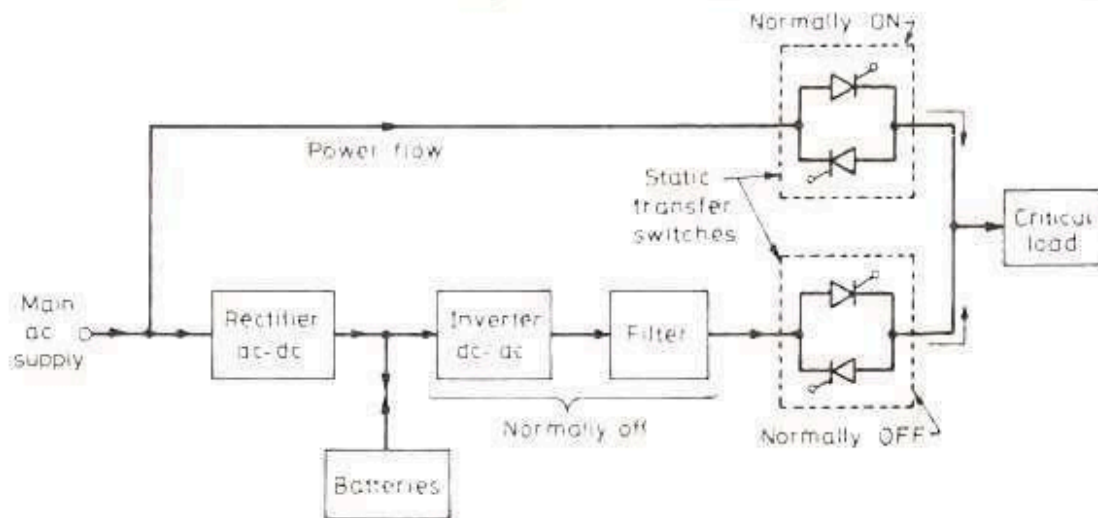

Fig. 11.8. Short-break static UPS configuration.

the supply (4 to 5 ms) to the load can be observed in case lamps and fluorescent tubes are a part of the load. When normally-on switch is opened and normally-off switch is turned on, lamps will have a transient dip in their illumination whereas the fluorescent tubes will be off momentarily and then get turned on. When the main ac supply appears, critical load gets connected, through normally-on switch, to the supply mains. Again, a momentary interruption in the illumination is noticed. The arrangement shown in Fig. 11.8 is also referred to as *stand-by power supply*.

No-break UPS. When a no-break supply is required, the static UPS system shown in Fig. 11.9 is used. In this system, main ac supply is rectified and the rectifier delivers power to maintain required charge on the batteries. Rectifier also supplies power to inverter continuously which is then given to ac-type load through filter and normally-on switch. In case of main-supply failure, batteries at once take over with no-break of supply to the critical load. No dip or discontinuity in the illumination is observed in case of no-break UPS. This configuration of Fig. 11.9 has the following additional advantages :

- (i) The inverter can be used to condition the supply delivered to load.
- (ii) Load gets protected from transients in the main ac supply.
- (iii) Inverter output frequency can be maintained at the desired value.

In case inverter failure is detected, the load is switched on to the main ac supply directly by turning on the normally-off static switch and opening the normally-on static switch. The transfer of load from inverter to main ac supply takes 4 to 5 ms by static transfer switch as compared to 40 to 50 ms for a mechanical contactor. After inverter fault is cleared, uninterruptible power supply is again restored to the load through the normally on switch. The batteries are now recharged from the main supply by adjusting the charger at maximum charge rate so that batteries are charged to their full capacity in the shortest possible time.

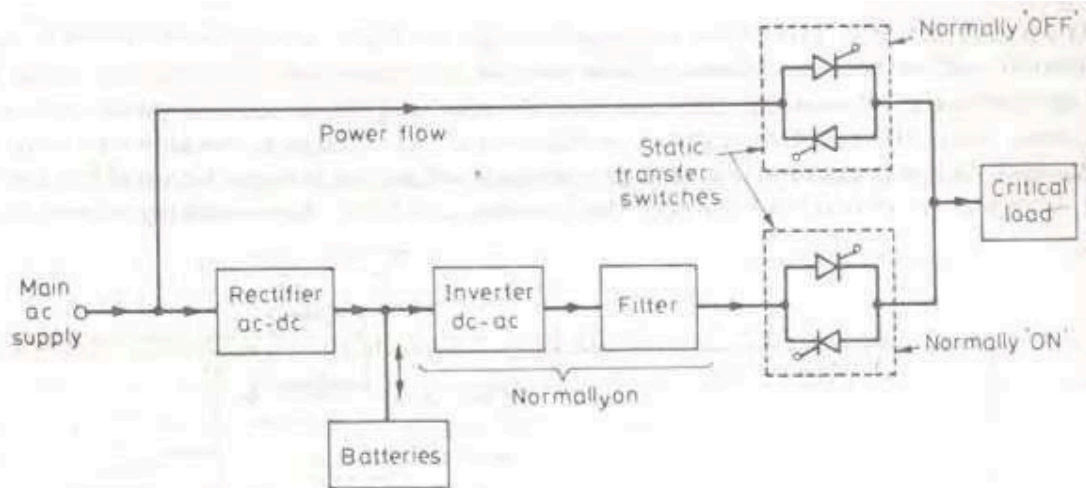

Fig. 11.9. No-break UPS configuration.

The standby batteries in the UPS system are either nickel-cadmium (NC) or lead-acid type. NC batteries have the following advantages :

- (a) Their electrolyte is non-corrosive.
- (b) Their electrolyte does not emit an explosive gas when charging.
- (c) NC batteries cannot be damaged by overcharging or discharging, these have therefore longer life.

Cost of NC batteries is, however, two or three times that of lead-acid batteries.

The time period for which a battery or a battery-bank can deliver power to load through inverter at the required voltage level depends upon (i) the size of the batteries and (ii) nature of the load.

4.10 BASIC SWITCHED MODE POWER SUPPLY (SMPS)

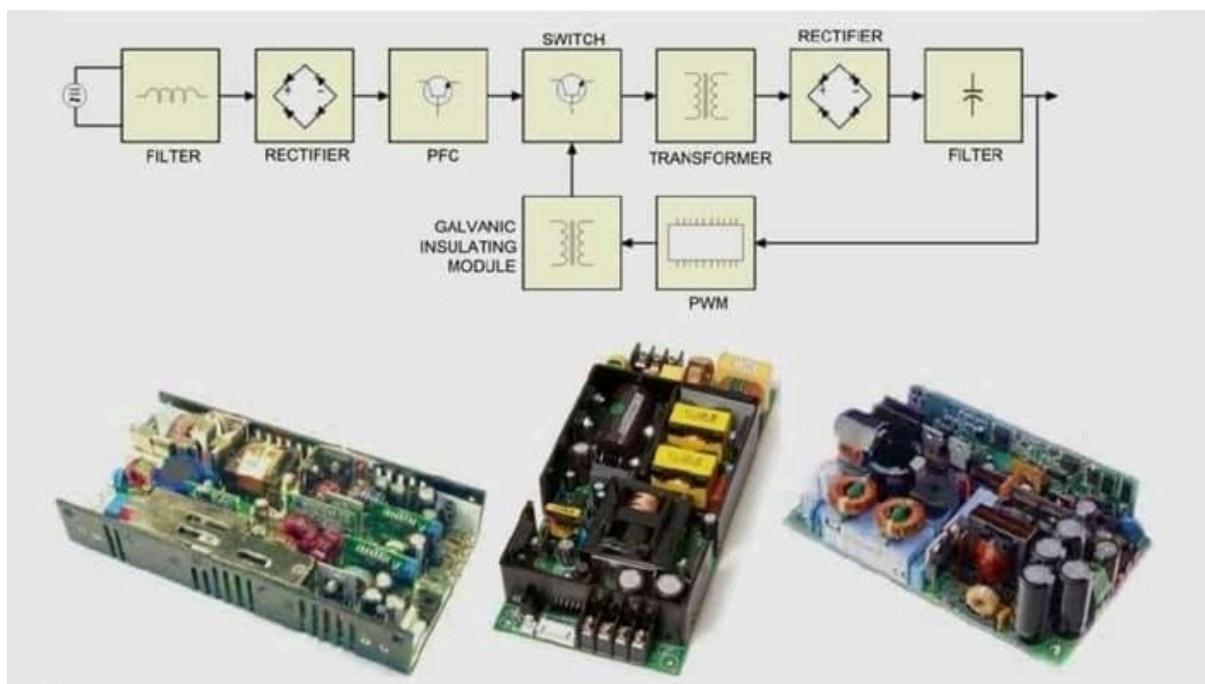

SMPS stands for switched mode power supply. It is known by a wide range of names like **power supply**, **supply unit**, **regulator**, or **switcher** in an electronic power supply. It incorporates a **switching regulator** to convert electrical power efficiently. It is mainly used for obtaining a **controlled dc power supply** as output.

It is used to convert power (voltage) using switching devices that are turned on and off alternatively at high frequencies. It uses storage components like **inductors** or **capacitors** to supply power when the switching device is in its non-conduction state (off-state). SMPS possesses **high efficiency** and is widely used in various electronic equipment such as computers, battery chargers, and other sensitive equipment requiring a **stable** and **efficient power supply**.

The **working & design** of SMPS is divided into various sections and stages.

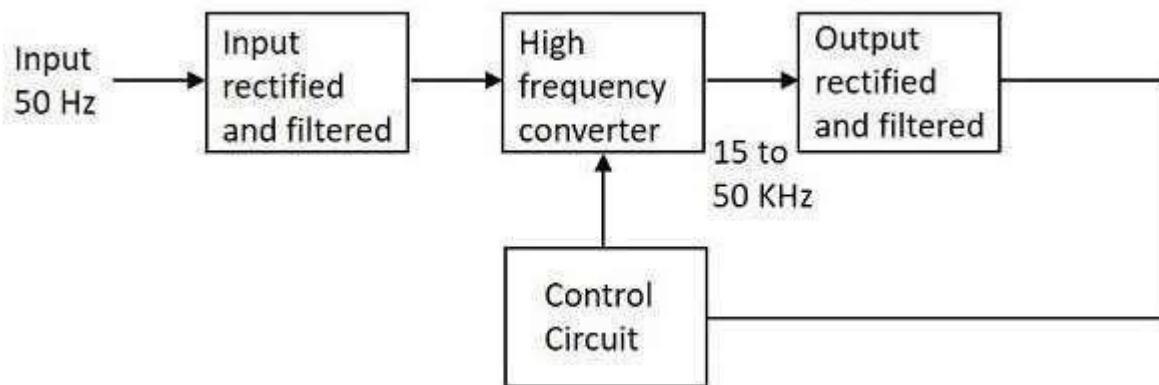

1: Input Stage

The AC input supply of frequency **(50-60)** Hz feeds directly to the **rectifier** and filter **circuit**. Its output contains many variations and the **capacitance value** of the capacitor should be higher enough to handle the input fluctuations. Finally, the **unregulated dc** is given to the central switching section of SMPS in order to regulate it. This section does not contain any transformer for the step down in **input voltage supply**.

2: Switching Section

It consists of **fast switching devices** like a **Power transistor** or a **MOSFET**, which switches ON and OFF according to the variations in the voltage. The output obtained is given to the primary of the **transformer** which is present in this section.

The transformer used here is a much smaller, lighter, and highly effective one that steps down voltage. These are much efficient compared to other step-down methods. Hence, the **power conversion ratio** is higher.

3: Output Stage

The output that is derived from the switching section is again rectified and filtered. It uses a rectification and filter circuit to get the desired DC voltage.

The obtained **regulated output voltage** is then given to the **control circuit**.

4: Control Unit

This unit is all about **feedback**, which has many sections contain in it. Lets see the brief information about this section.

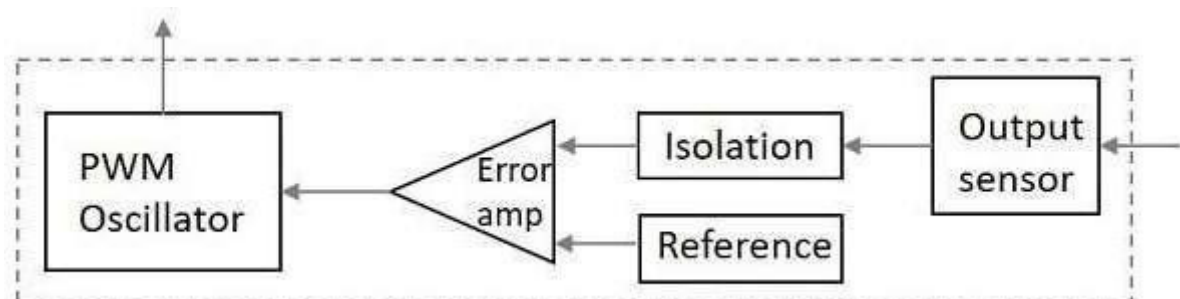

The inner control unit consists of an **oscillator**, **amplifier**, **sensor**, etc. The sensor senses the **output signal** and **feedback** to the control unit. All the signals

are isolated from each other so that, any sudden spikes should not affect the circuitry. The **reference voltage** is given as one input along with the signal to the **error amplifier**. The amplifier is a **comparator** that compares the signal with the required signal level.

The next stage is **Controlling the chopping frequency**. The final voltage level

is controlled by comparing the inputs given to the error amplifier, whose output helps to decide whether to increase or to decrease the chopping

frequency.

The **oscillator** produces a standard PWM wave with a fixed frequency.

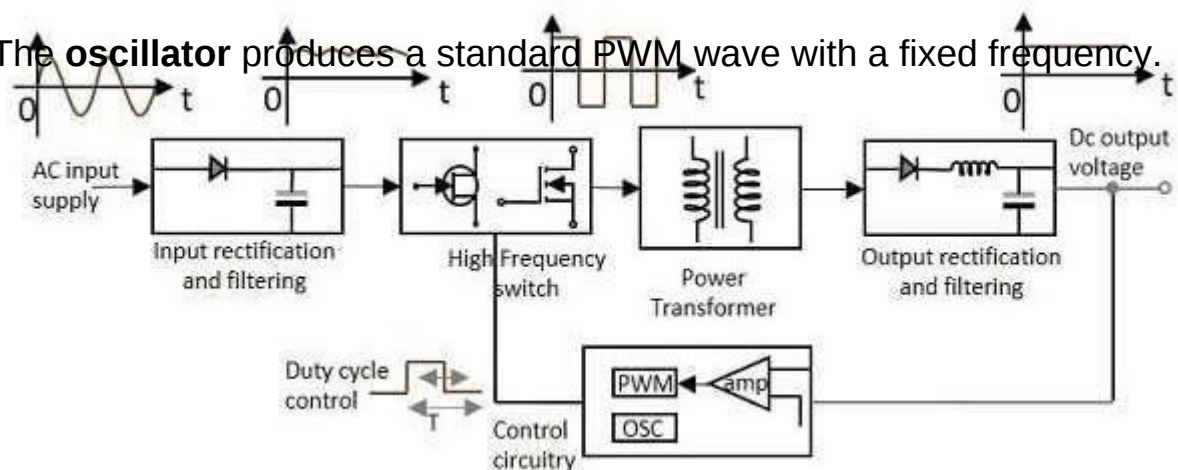

Types of SMPS:

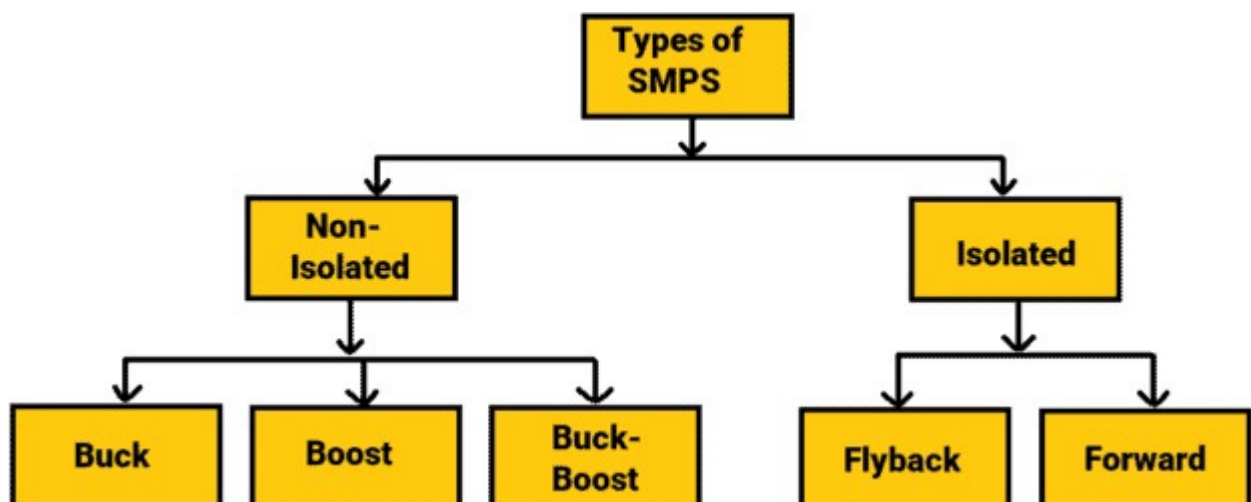

1: Non-isolated

Non-isolated converters are mostly used when the change in the voltage is comparatively small. The non-isolated SMPS are the ones whose input and output circuitry are not isolated from each other. The major disadvantage is that it cannot provide **protection** from **high electrical voltages** and it poses more noise. They are of 3 types.

I: Buck

In a typical non-isolated step-down (buck) converter the output voltage V_{OUT} depends on the input voltage V_{IN} and the switching duty cycle of the power switch.

II: Boost

It is used to boost voltage and it uses the same number of passive components but arranged to step up the input voltage so that the output is higher than that of the input.

III: Buck-Boost

This converter allows the input voltage to be either stepped-up or stepped-down, depending on the duty cycle. The output voltage is given by the relation $V_{OUT} = -V_{IN} * D / (1-D)$

2: Isolated

Isolated SMPS are the ones where there is isolation maintained between the input and output circuitry. The supplies make use of a transformer to separate the switching from the output. The secondary winding of the transformer acts as the energy storing element.

I: Fly-back Converter:

The working of this converter is similar to the buck-boost converter of the non-isolating category. The only difference is that it uses a transformer to store energy instead of an inductor in the circuit.

II: Forward Converter

The working of this converter makes use of the transformer to send the energy, between the input and output in a single step.

Application of Switched Mode power supply (SMPS)

- It is used in servers, power stations, and personal computers.
- It is used in vehicles for charging batteries.
- It is used in factories and industries for power.
- It is used in the railway system, security system.
- It is also used in mobile and also as lighting.

MODULE-5

PLC AND ITS APPLICATIONS

Introduction of Programmable Logic Controller (PLC)

Programmable logic controllers are now the most widely used industrial process control technology. A programmable logic controller (PLC) is an industrial grade computer that is capable of being programmed to perform control functions. The programmable controller has eliminated much of the hardwiring associated with conventional relay control circuits. Other benefits include easy programming and installation, high control speed, network compatibility, troubleshooting and testing convenience, and high reliability. The programmable logic controller is designed for multiple input and output arrangements, extended temperature ranges, immunity to electrical noise, and resistance to vibration and impact. Programs for the control and operation of manufacturing process equipment and machinery are typically stored in battery-backed or non-volatile memory. A PLC is an example of a real-time system since the output of the system controlled by the PLC depends on the input conditions. The programmable logic controller is, then, basically a digital computer designed for use in machine control. Unlike a personal computer, it has been designed to operate in the industrial environment and is equipped with special input/output interfaces and a control programming language. The common abbreviation used in industry for these devices, PC, can be confusing because it is also the abbreviation for “personal computer.” Therefore, most manufacturers refer to their programmable controller as a PLC, which stands for “programmable logic controller.”

Advantages of PLC

Programmable controllers offer several advantages over a conventional relay type of control. Relays have to be hardwired to perform a specific function. When the system requirements change, the relay wiring has to be changed or modified. In extreme cases, such as in the auto industry, complete control panels had to be replaced since it was not economically feasible to rewire the old panels with each model changeover. The programmable controller has eliminated much of the hardwiring associated with conventional relay control circuits. It is small and inexpensive compared to equivalent relay-based process control systems. Modern control systems still include relays, but these are rarely used for logic. In addition to cost savings, PLCs provide many other benefits including:

- *Increased Reliability.* Once a program has been written and tested, it can be easily downloaded to other PLCs. Since all the logic is contained in the PLC's memory, there is no chance of making a logic wiring error. The program takes the place of much of the external wiring that would normally be required for

control of a process. Hardwiring, though still required to connect field devices, is less intensive. PLCs also offer the reliability associated with solid-state components.

- More Flexibility.* It is easier to create and change a program in a PLC than to wire and rewire a circuit. With a PLC the relationships between the inputs and outputs are determined by the user program instead of the manner in which they are interconnected. Original equipment manufacturers can provide system updates by simply sending out a new program. End users can modify the program in the field, or if desired, security can be provided by hardware features such as key locks and by software passwords.

- Lower Cost.* PLCs were originally designed to replace relay control logic, and the cost savings have been so significant that relay control is becoming obsolete except for power applications. Generally, if an application has more than about a half-dozen control relays, it will probably be less expensive to install a PLC.

- Communications Capability.* A PLC can communicate with other controllers or computer equipment to perform such functions as supervisory control, data gathering, monitoring devices and process parameters, and download and upload of programs.

- Faster Response Time.* PLCs are designed for high-speed and real-time applications. The programmable controller operates in real time, which means that an event taking place in the field will result in the execution of an operation or output. Machines that process thousands of items per second and objects that spend only a fraction of a second in front of a sensor require the PLC's quick-response capability.

- Easier to Troubleshoot.* PLCs have resident diagnostics and override functions that allow users to easily trace and correct software and hardware problems. To find and fix problems, users can display the control program on a monitor and watch it in real time as it executes.

Different parts of PLC by drawing the block diagram and purpose of each part of PLC

A typical PLC can be divided into parts, as illustrated in Figure 1-8.

These are

the central processing unit (CPU), the input/output (I/O) section, the power supply, and the programming device.

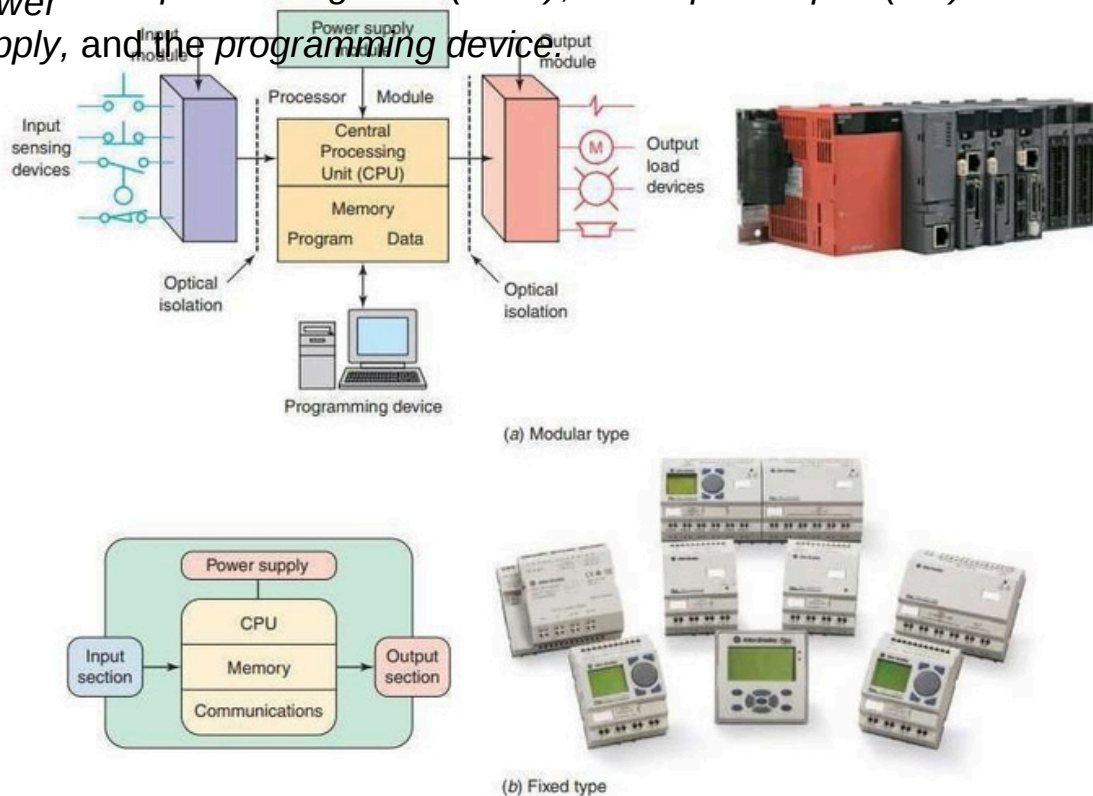

Figure 1-8 Typical parts of a programmable logic controller.
Source: (a) Courtesy Mitsubishi Automation; (b) Image Used with Permission of Rockwell Automation, Inc.

The term *architecture* can refer to PLC hardware, to PLC software, or to a combination both. An *open* architecture design allows the system to be connected easily to devices and programs made by other manufacturers.

There are two ways in which I/Os (Inputs/Outputs) are incorporated

into the

PLC: fixed and modular. *Fixed I/O* is typical of small PLCs that come in package with no separate, removable units. The processor and I/O are

packaged

together, and the I/O terminals will have a fixed number of connections for inputs and outputs. The main advantage of this type of packaging is

lower

cost. The number of available I/O points varies and usually can be expanded by buying additional units of fixed I/O. One disadvantage of fixed I/O is its

lack of

flexibility; you are limited in what you can get in the quantities and types dictated by the packaging. Also, for some models, if any part in the unit

Modular I/O is divided by compartments into which separate modules can be plugged. This feature greatly increases your options and the unit's flexibility. You can choose from the modules available from the manufacturer and mix them any way you desire. The basic modular controller consists of a rack, power supply, processor module (CPU), input/output (I/O modules), and an operator interface for programming and monitoring. The modules plug into a rack. When the module is slid into the rack, it makes an electrical connection with a series of contacts called the backplane, located at the rear of the rack. The PLC processor is also connected to the backplane and can communicate with all the modules in the rack.

The *power supply* supplies DC power to other modules that plug into the rack. For large PLC systems, this power supply does not normally supply power to the field devices. With larger systems, power to field devices is provided by external alternating current (AC) or direct current (DC) supplies. For some small micro-PLC systems, the power supply may be used to power field devices.

The *processor* (CPU) is the "brain" of the PLC. A typical processor usually consists of a microprocessor for implementing the logic and controlling the communications among the modules. The processor requires memory for storing the results of the logical operations performed by the microprocessor. Memory is also required for the program EPROM or EEPROM plus RAM. The CPU controls all PLC activity and is designed so that the user can enter the desired program in relay ladder logic. The PLC program is executed as part of a repetitive process referred to as a scan. A typical PLC scan starts with the CPU reading the status of inputs. Then, the application program is executed. Once the program execution is completed, the CPU performs internal diagnostic and communication tasks. Next, the status of all outputs is updated. This process is repeated continuously as long as the PLC is in the run mode.

The *I/O system* forms the interface by which field devices are connected to the controller. The purpose of this interface is to condition the various signals received from or sent to external field devices. Input devices such as pushbuttons, limit switches, and sensors are hardwired to the input terminals. Output devices such as small motors, motor starters, solenoid valves, and indicator lights are hardwired to the output terminals. To electrically isolate the internal components from the input and output terminals, PLCs commonly employ an optical isolator, which uses light to couple the circuits together.

A *programming device* is used to enter the desired program into the memory of the processor. The program can be entered using relay ladder logic, which is one of the most popular programming languages. Instead of words, ladder logic programming language uses graphic symbols that show their intended outcome.

A program in ladder logic is similar to a schematic for a relay control circuit. It is a special language written to make it easy for people familiar with relay logic control to program the PLC.

A personal computer (PC) is the most commonly used programming device. Most brands of PLCs have software available so that a PC can be used as the programming device. This software allows users to create, edit, document, store, and troubleshoot ladder logic programs. The computer monitor is able to display more logic on the screen than can hand-held types, thus simplifying the interpretation of the program. The personal computer communicates with the PLC processor via a serial or parallel data communications link, or Ethernet. If the programming unit is not in use, it may be unplugged and removed. Removing the programming unit will not affect the operation of the user program.

A *program* is a user-developed series of instructions that directs the PLC to execute actions. A *programming language* provides rules for combining the instructions so that they produce the desired actions.

Relay ladder logic (RLL) is the standard programming language used with PLCs. Its origin is based on electromechanical relay control. The relay ladder logic program graphically represents rungs of contacts, coils, and special instruction blocks. RLL was originally designed for easy use and understanding for its users and has been modified to keep up with the increasing demands of industry's control needs.

Application of PLC

There are three major types of PLC application: single ended, multitask, and control management.

A *single ended* or stand-alone PLC application involves one PLC controlling one process. This would be a stand-alone unit and would not be used for communicating with other computers or PLCs. The size and sophistication of the process being controlled are obvious factors in determining which PLC to select. The applications could dictate a large processor, but usually this category requires a small PLC.

A *multitask* PLC application involves one PLC controlling several processes. Adequate I/O capacity is a significant factor in this type of installation. In addition, if the PLC would be a subsystem of a larger process and would have to communicate with a central PLC or computer, provisions for a data communications network are also required.

A *control management* PLC application involves one PLC controlling several others. This kind of application requires a large PLC processor designed to

communicate with other PLCs and possibly with a computer. The control management PLC supervises several PLCs by downloading programs that tell the other PLCs what has to be done. It must be capable of connection to all the PLCs so that by proper addressing it can communicate with anyone it wishes to

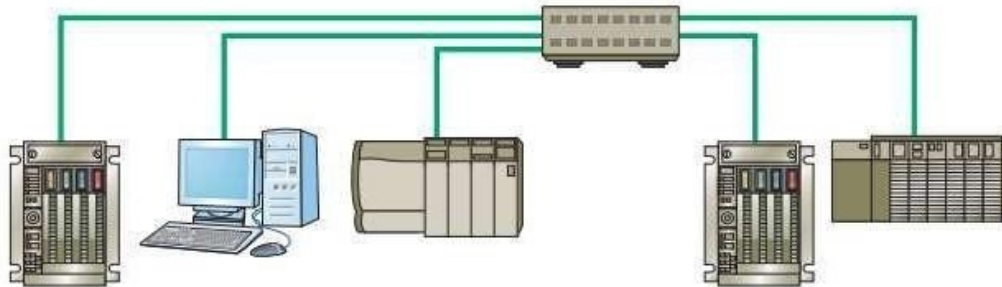

Figure 1-30 Control management PLC application.

Because of the versatility of PLC, it is used in various places for automation. In industries various processes needs to be controlled at every instant of time such as valve control, pressure control, robotic action, etc. It becomes tedious and infeasible for humans to control all such activities on their own. Thus, relays were used to perform those activities. However, a relay can be used only for a specific and limited operation which makes their use bulky and uneconomic. On the contrary PLC having the ability to perform number of tasks by simply modifying the program has become a prominent device for automation of such activities. There are various places where a PLC can be used. Some of those are listed as below:

- Robotic arm in car manufacturing
- Air compressors
- Airport runway lighting control
- Traffic signal control
- Smoke alarm control
- Process valve control
- Textile equipment
- Vacuum pump system

Apart from these applications, PLC is widely used in automation of electrical power system. At electrical substations automatic reclosing, circuit breaker tripping, capacitor switching, etc. can be controlled with PLCs.

Ladder diagram

- Lets use a PLC in place of the relay.
- The first thing that's necessary is to create what's called a **Ladder Diagram**.
- We have to create one of these because, unfortunately, a PLC doesn't understand a schematic diagram it only recognizes code.
- Most PLCs have software which convert ladder diagrams into code.

• **First Step** : Translate all of the items we're using into symbols the PLC understands.

• **Second step** : We must tell the PLC where everything is located. In other words we have to give all the devices an address.

• **Final step** : We have to convert the schematic into a logical sequence of events.

First step:

- The PLC doesn't understand terms like switch, relay, bell, etc.
- It prefers input, output, coil, contact, etc.
- It doesn't care what the actual input or output device actually is. It only cares that it's an input or an output.
- First we replace the battery with a symbol. This symbol is common to all ladder diagrams. We draw what are called **bus bars**.
- These simply look like two vertical bars. One on each side of the diagram. Think of the left one as being + voltage and the right one as being ground. Further think of the current (logic) flow as being from left to right.
- Next we give the **inputs** a symbol. In this basic example we have one real world input. (i.e. the switch).
- We give the input that the switch will be connected to the symbol shown below. This symbol can also be used as the **contact of a relay**.



A contact symbol

• Next we give the **outputs** a symbol. In this example we use one output (i.e. the bell).

• We give the output that the bell will be physically connected to the symbol shown below. This symbol is used as the coil of a relay.

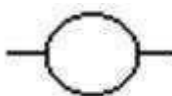

A coil symbol

- The AC supply is an external supply so we don't put it in our ladder. The PLC only cares about which output it turns on and not what's physically connected to it.

Second step:

- We must tell the PLC where everything is located. In other words we have to give all the devices an address.

- Where is the switch going to be physically connected to the PLC? How about the bell? We start with a blank road map in the PLCs town and give each item an address.

- Could you find your friends if you didn't know their address? You know they live in the same town but which house? The plc town has a lot of houses (inputs and outputs) but we have to figure out who lives where (what device is connected where).

- We'll get further into the addressing scheme later. The PLC manufacturers each do it a different way! For now let's say that our input will be called "0000". The output will be called "500".

Final step:

- Convert the schematic into a logical sequence of events.

- The program we're going to write tells the PLC what to do when certain events take place.

- In our example we have to tell the plc what to do when the operator turns on the switch.

- Final converted diagram.
- We eliminated the real world relay from needing a symbol.

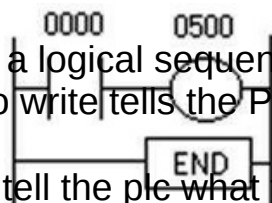

Description of contacts and coils in the following states

i)Normally

open Load :

- The load(LD) instruction is a **normally open contact**. It is sometimes also called examine if on (**XIO**).(as in examine the input to see if its physically on). The symbol for a load instruction is shown below.



A Load (contact) symbol

- This is used when an input signal is needed to be present for the symbol to turn on.
- When the physical input is on we can say that the instruction is True.
- We examine the input for an on signal. If the input is physically on then the symbol is on.
- An on condition is also referred to as a logic 1 state.

ii) Normally

closed Load Bar :

- The Load bar instruction is a **normally closed contact**. It is sometimes also called LoadNot or examine if closed (**XIC**) (as in examine the input to see if its physically closed) The symbol for a loadbar instruction is shown below.



A LoadNot (normally closed contact) symbol

- This is used when an input signal does not need to be present for the symbol to turn on.
- When the **physical input is off** we can say that the **instruction is True**.
- We examine the input for an off signal. If the input is physically off then the symbol is on.
- With most PLCs this instruction (**Load** or **Loadbar**) **MUST** be the first symbol on the left of the ladder.

<u>Physical State</u>	<u>Instruction</u>	<u>Logic</u>
OFF	TRUE	0
ON	FALSE	1

iii) Energized output

out:

- The Out instruction is sometimes also called an **Output Energize instruction**. The output instruction is like a **relay coil**. Its symbol looks as shown below.
- When there is a path of True instructions preceding this on the ladder rung, it will also be True.

- When the **instruction is True** it is **physically ON**.
- We can think of this instruction as a normally open output.

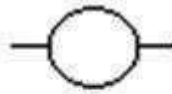

An OUT (coil) symbol

Output energize (OTE)

- Alternate name: coil
- This instruction is usually used in conjunction with **XIC** or **XIO** or any other input instruction.
- If the logic preceding the OTE instruction is true (1), the OTE instruction will be energized

Instruction symbol

An OTE instruction can **only** be the last instruction on a rung.

Not energized

Energized

iv)Latched output

Output latch (OTL)

- The OTL instruction is used only to turn a bit on and latch it on

Instruction symbol

Initially not energized

Energized

Latched

Out bar:

- The Outbar instruction is sometimes also called an OutNot instruction.
- The Outbar instruction is like a **normally closed relay coil**. Its symbol looks like that shown below.

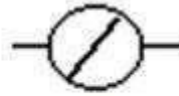

An OUTBar (normally closed coil) symbol

Ladder diagrams

i)AND gate

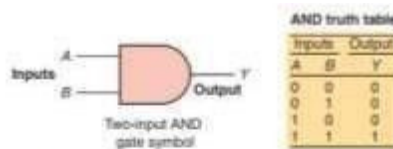

Figure 4-3 AND gate.

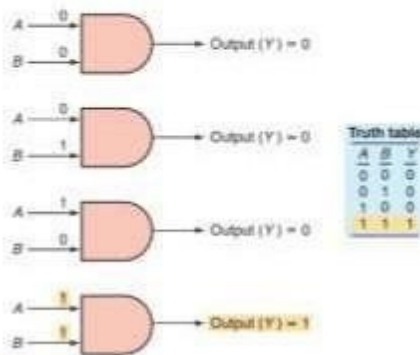

Figure 4-4 AND logic gate digital signal states.

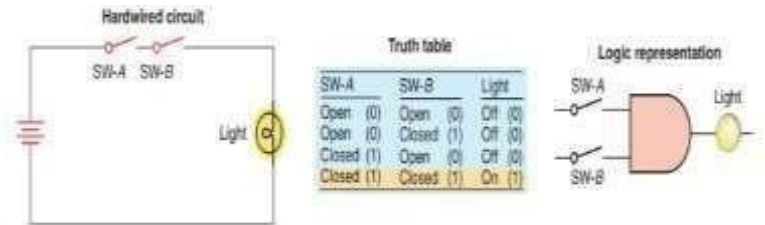
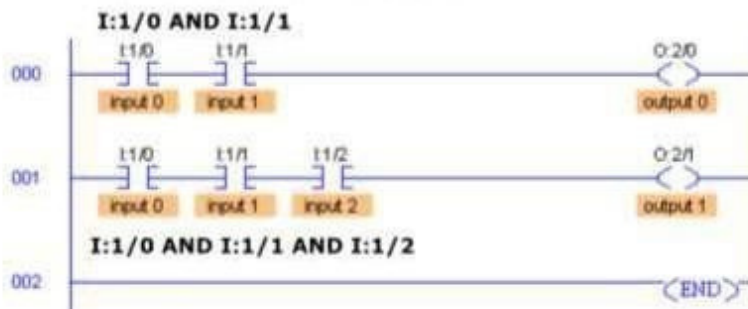

Figure 4-5 AND logic gate operates similarly to control devices connected in series.

Logical AND ladder diagram

- The logical AND function is constructed by series combinations of digital (discrete) inputs
 - Two (or more) series components



ii) OR gate

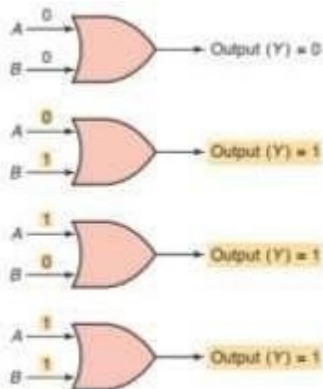

Truth table		
Inputs		Output
A	B	Y
0	0	0
0	1	1
1	0	1
1	1	1

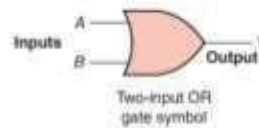

OR truth table		
Inputs		Output
A	B	Y
0	0	0
0	1	1
1	0	1
1	1	1

Figure 4-7 OR logic gate digital signal states.

Figure 4-8 OR gate.

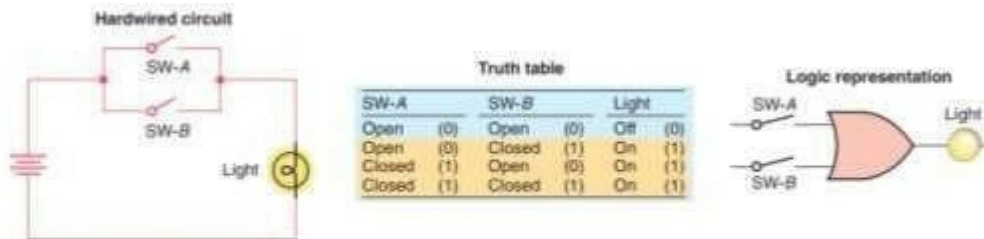
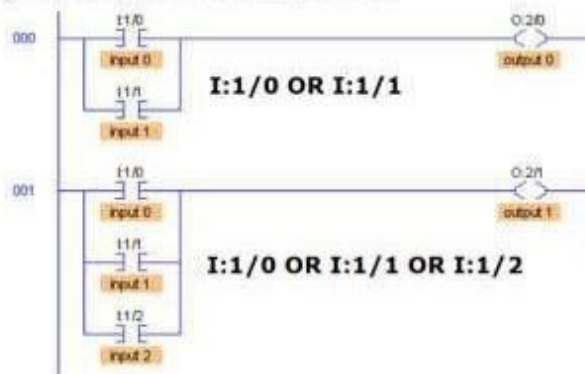

Figure 4-8 OR logic gate operates similarly to control devices connected in parallel.

Logical OR ladder diagram

- The logical OR function is constructed by parallel combinations of digital (discrete) inputs
 - Two (or more) parallel components



iii) NOT gate

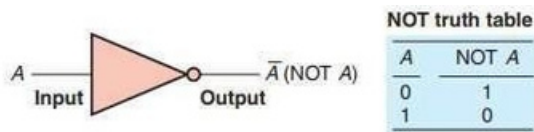

Figure 4-9 NOT function.

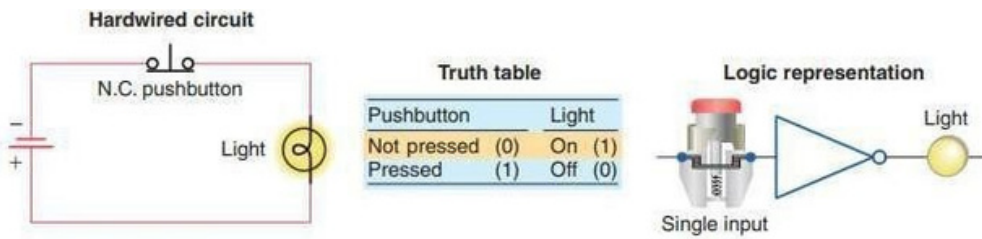
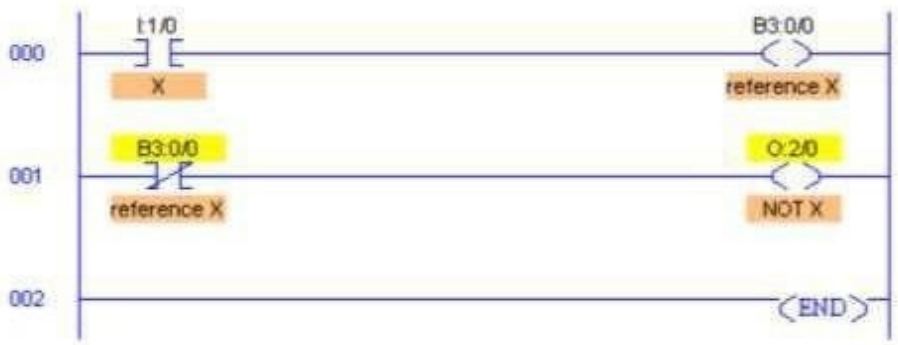

Figure 4-10 NOT function constructed using a normally closed pushbutton.







Logical NOT

- The logical NOT function is constructed by referencing the input signal with a normally closed contact (XIO instruction)

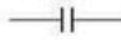
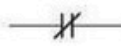
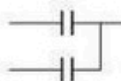
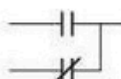

Ladder diagrams for combination circuits using NAND, NOR, OR and NOT

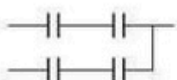
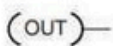
Table 4-1 Typical Boolean Instruction or Statement List

Boolean Instruction and Function	Graphic Symbol
Store (STR)–Load (LD) Begins a new rung or an additional branch in a rung with a normally open contact.	
Store Not (STR NOT)–Load Not (LD NOT) Begins a new rung or an additional branch in a rung with a normally closed contact.	
Or (OR) Logically ORs a normally open contact in parallel with another contact in a rung.	
Or Not (OR NOT) Logically ORs a normally closed contact in parallel with another contact in a rung.	
And (AND) Logically ANDs a normally open contact in series with another contact in a rung.	
And Not (AND NOT) Logically ANDs a normally closed contact in series with another contact in a rung.	
And Store (AND STR)–And Load (AND LD) Logically ANDs two branches of a rung in series.	
Or Store (OR STR)–Or Load (OR LOAD) Logically ORs two branches of a rung in parallel.	
Out (OUT) Reflects the status of the rung (on/off) and outputs the discrete (ON/OFF) state to the specified image register point or memory location.	
Or Out (OR OUT) Reflects the status of the rung and outputs the discrete (ON/OFF) state to the image register. Multiple OR OUT instructions referencing the same discrete point can be used in the program.	
Output Not (OUT NOT) Reflects the status of the rung and turns the output OFF for an ON execution condition; turns the output ON for an OFF execution condition.	

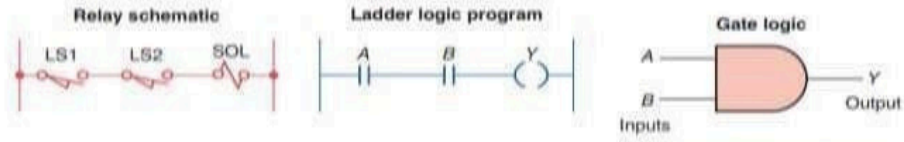

Boolean equation: $AB = Y$

Example 4-1 Two limit switches connected in series and used to control a solenoid valve.

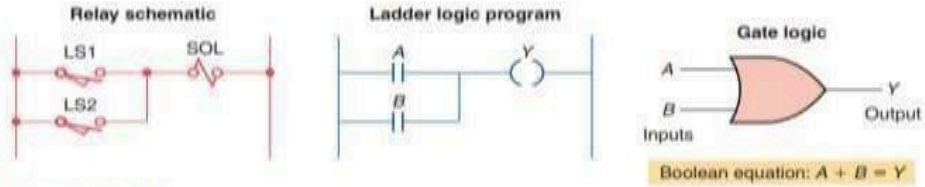

Boolean equation: $A + B = Y$

Example 4-2 Two limit switches connected in parallel and used to control a solenoid valve.

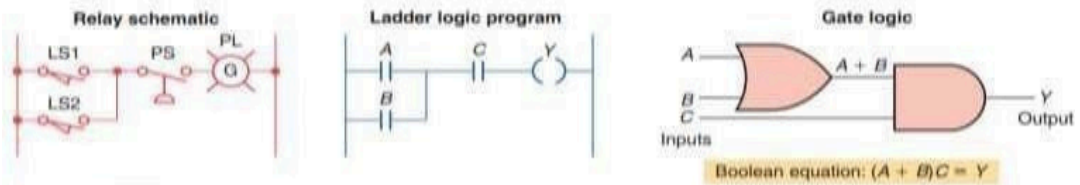

Boolean equation: $(A + B)C = Y$

Example 4-3 Two limit switches connected in parallel with each other and in series with a pressure switch.

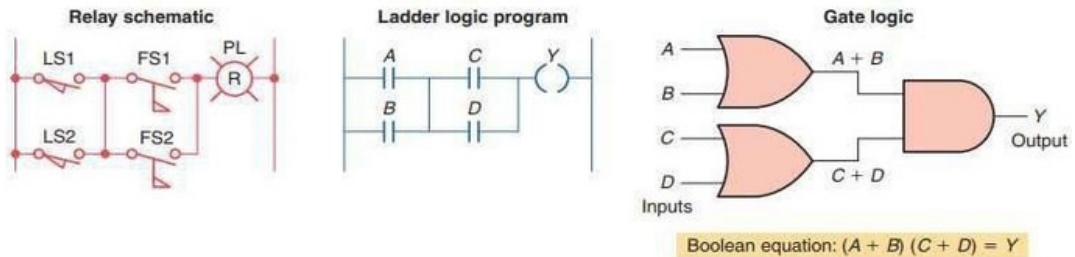

Boolean equation: $(A + B)(C + D) = Y$

Example 4-4 Two limit switches connected in parallel with each other and in series with two sets of flow switches (that are connected in parallel with each other), and used to control a pilot light.

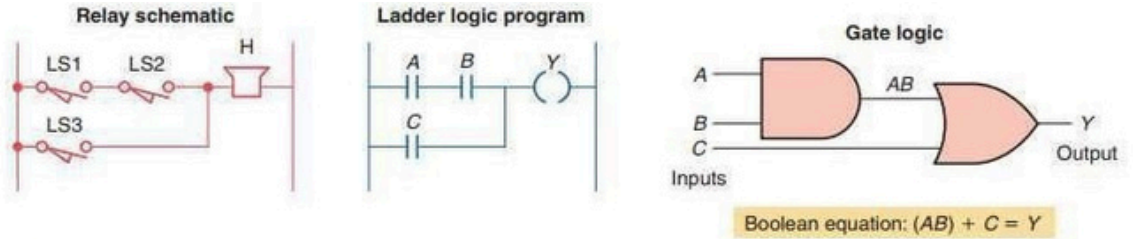

Example 4-5 Two limit switches connected in series with each other and in parallel with a third limit switch, and used to control a warning horn.

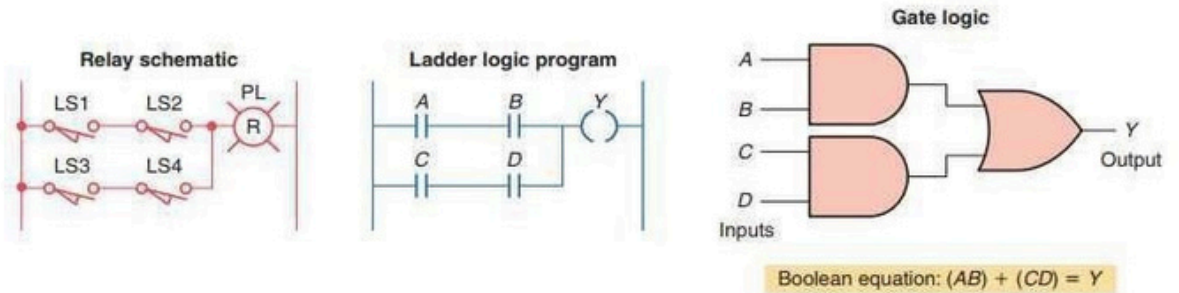

Example 4-6 Two limit switches connected in series with each other and in parallel with two other limit switches (that are connected in series with each other), and used to control a pilot light.

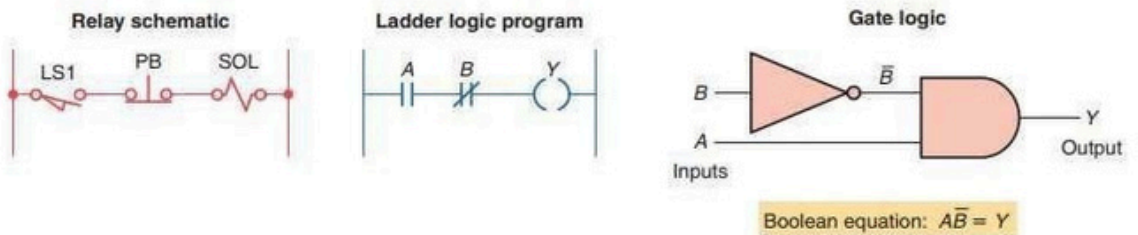

Example 4-7 One limit switch connected in series with a normally closed pushbutton and used to control a solenoid. This circuit is programmed so that the output solenoid will be turned on when the limit switch is closed and the pushbutton is *not pushed*.

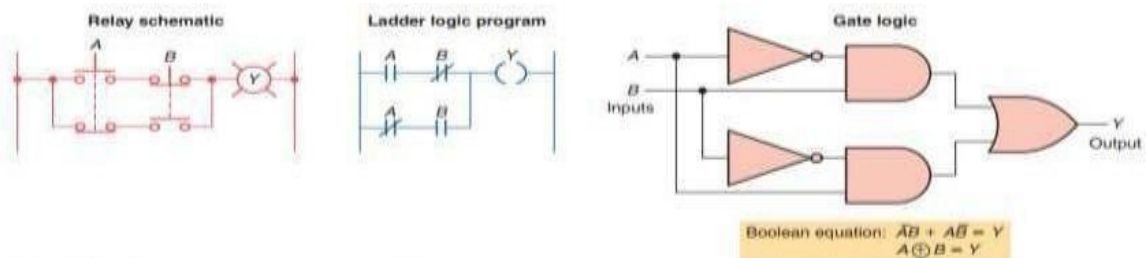

Example 4-8 Exclusive-OR circuit. The output lamp of this circuit is ON only when pushbutton A or B is pressed, but not both. This circuit has been programmed using only the normally open A and B pushbutton contacts as the inputs to the program.

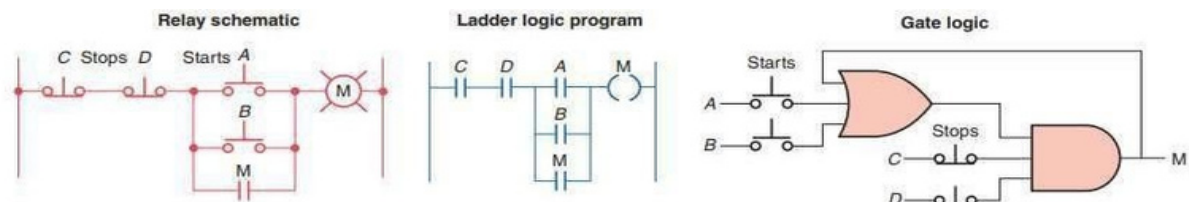

Example 4-9 A motor control circuit with two start/stop buttons. When either start button is depressed, the motor runs. By use of a seal-in contact, it continues to run when the start button is released. Either stop button stops the motor when it is depressed.

Timers)T ON

- **TIMER** : It is an instruction that waits a set amount of time before doing something.
- Type of Timers : On-Delay Timer and Off-Delay Timer.
- **On-Delay Timer** :
 - Simply "delays turning on".
 - After sensor (input) turns ON, wait x-seconds before activating a solenoid valve(output).
 - This is the most common timer. It is often called **TON**(timer on-delay), **TIM**(timer) or **TMR**(timer).

Non-retentive Timers

- A single-input timer called a *non-retentive* timer is used in some PLCs.
 - Energizing I:1/0 causes the timer to run for 4 seconds.
 - At the end of 4 seconds the output (DN) goes on. When the input is de-energized, the output goes off and the timer resets to 0.
 - If the input I:1/0 is turned off during the timing interval (for example, after 2.7 seconds), the timer resets to 0.
 - **TON** is the basic non-retentive timer in Allen-Bradley PLCs

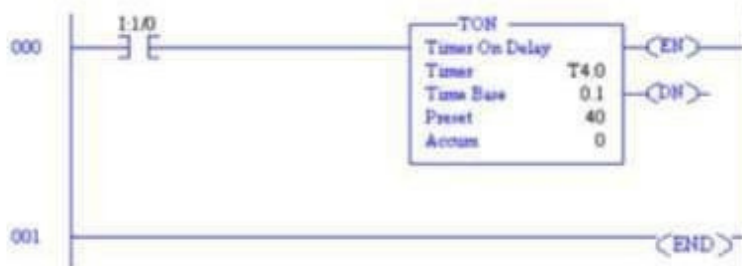

Timer Information

	/EN	/TT	/DN	PRE	ACC
T4.0	1	0	1	40	-40
T4.1	0	0	0	0	0
T4.2	0	0	0	0	0
T4.3	0	0	0	0	0
T4.4	0	0	0	0	0

Radix: Decimal Table: T4: Timer

Address: Symbol:

- The timer table contains all information for that timer
 - /EN: Timer is enabled (i.e. the input rung is energized)
 - /TT: Timer is timing
 - /DN: Timer is done
 - .PRE: Timer preset value (point at which the timer stops timing)
 - .ACC: Timer accumulator (accumulated time value)

ii) T OFF

Off-Delay Timer :

- Simply "delays turning off".
- After sensor (input) sees a target it turn on a solenoid (output).
- When the sensor no longer sees the target it hold the solenoid on for x-seconds before turning it off.
- It is called a TOF (timer off-delay).

Timer Delay Off (TOF)

- The TOF timer functions the opposite of the TON timer.
 - De-Energizing I:1/0 causes the timer to run for 4.5 seconds. The DN bit is initially set.
 - At the end of 4.5 seconds the output (DN) goes off. When the input is energized the timer resets to 0.
 - If the input I:1/0 is turned on during the timing interval (for example, after 2.7 seconds), the timer resets to 0.



iii) Retentive timer

Retentive Timers (RTO)

- Functions exactly like TON except the accumulated time value is retained even if the input rung is de-energized.

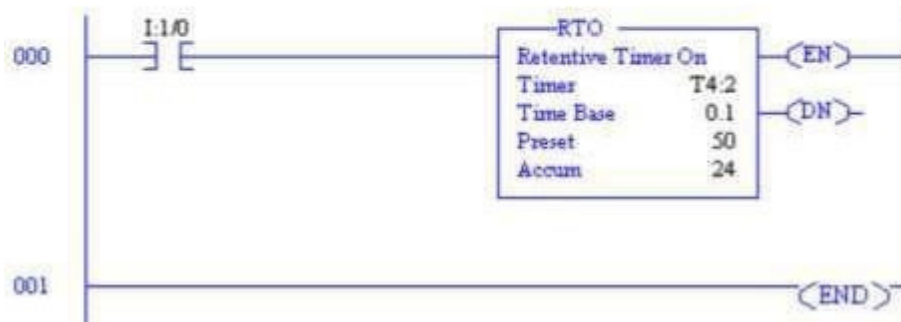

CountersCTU

Up Counter (CTU)

- The CTU is an instruction that counts false-to-true rung transitions.
 - Rung transitions can be caused by events occurring in the program (from internal logic or by external devices) such as parts traveling past a detector or actuating a limit switch.
- When rung conditions for a CTU instruction have made a false-to-true transition, the accumulated value is incremented by one count, provided that the rung containing the CTU instruction is evaluated between these transitions.
 - The ability of the counter to detect false-to-true transitions depends on the speed (frequency) of the incoming signal.
- The accumulated value is retained when the rung conditions again become false.
- The accumulated count is retained until cleared by a reset (RES) instruction.

CTD

Down Counter (CTD)

- The CTD is an instruction that counts false-to-true rung transitions.
 - Rung transitions can be caused by events occurring in the program such as parts traveling past a detector or actuating a limit switch.
- When rung conditions for a CTD instruction have made a false-to-true transition, the accumulated value is decremented by one count, provided that the rung containing the CTD instruction is evaluated between these transitions.
- The accumulated counts are retained when the rung conditions again become false.
- The accumulated count is retained until cleared by a reset (RES) instruction.

Ladder diagram using Timers and Counters

Up Counter Example

- Accumulated count is reset only by the (RES) instruction
- The counter will increment the accumulator value even after the preset is reached



Down Counter Example

- Accumulated count is reset only by the (RES) instruction
- The counter will decrement the accumulator value even after a 0 count is reached



Ladder Logic Example

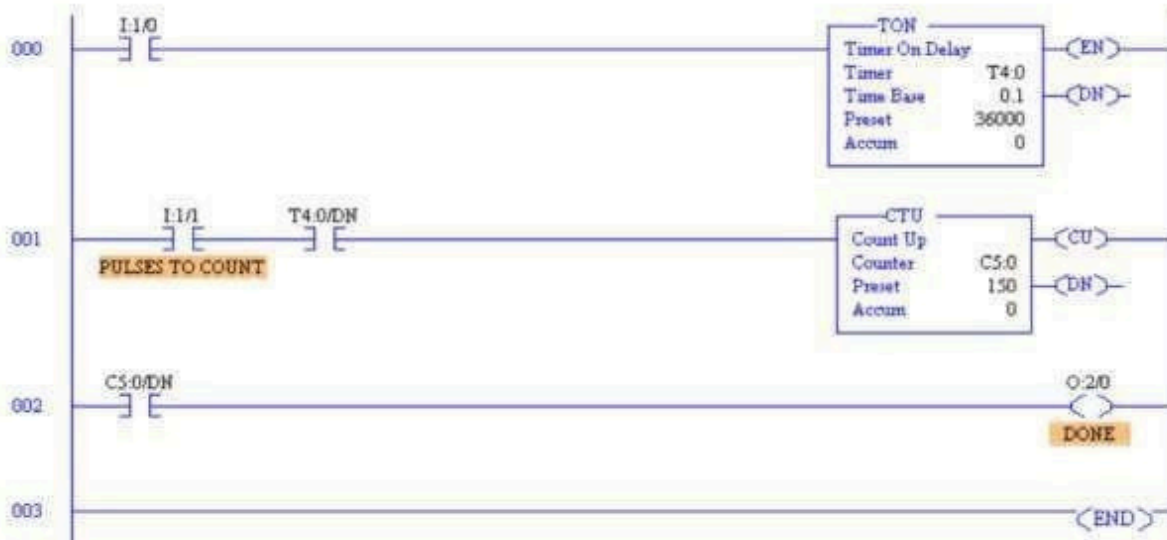

Ladder diagram for DOL starter

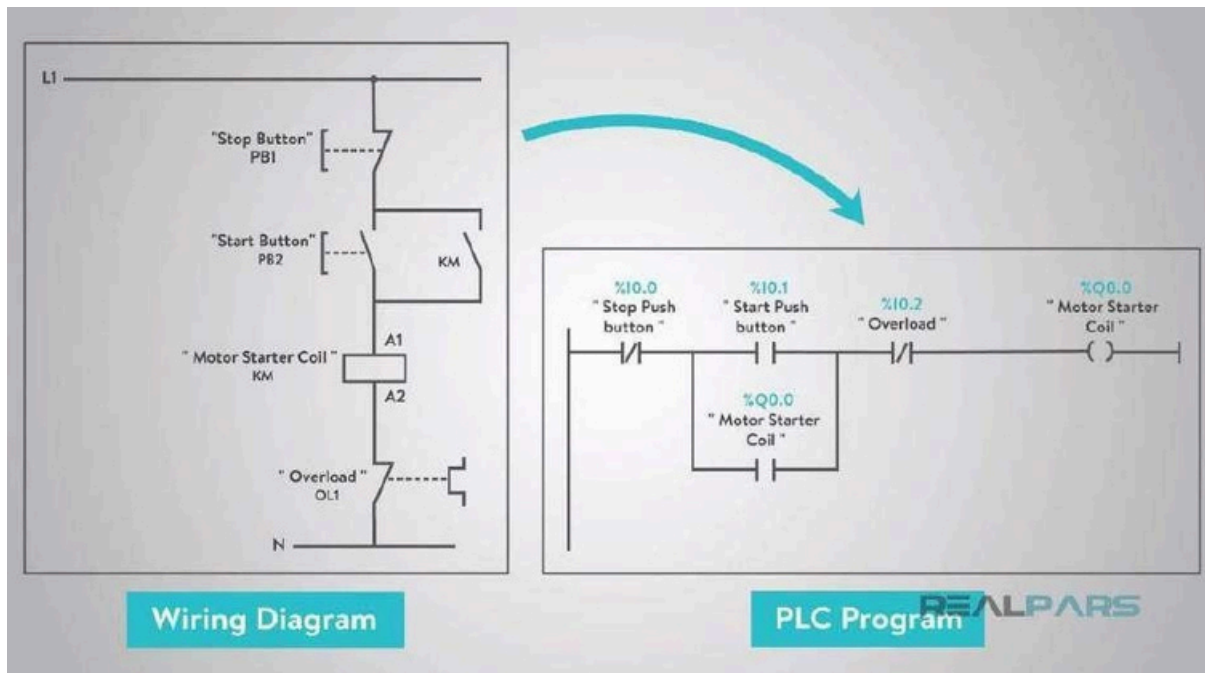

STAR-DELTA MOTOR STARTER LADDER LOGIC

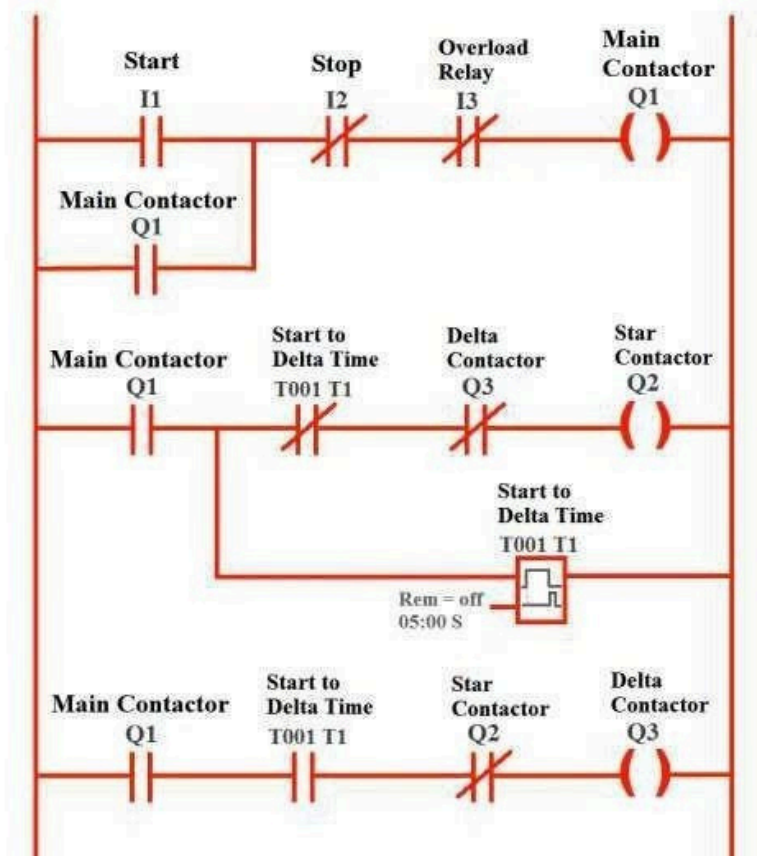

SPECIAL CONTROL SYSTEMS

DCS:

A distributed control system (DCS) is part of a manufacturing system.

Distributed control systems (DCS) are used in industrial and civil engineering applications to monitor and control distributed equipment with remote human intervention.

It is generally, since the 1970s, digital, and normally consists of field instruments, connected via wiring to computer buses or electrical buses to multiplexer/demultiplexers and A/D's or analog to digital and finally the Human-Machine Interface (HMI) or control consoles. A DCS is a process control system that uses a network to interconnect sensors, controllers, operator terminals and actuators. A DCS typically contains one or more computers for control and mostly use both proprietary interconnections and protocols for communications. See PAS.

DCS is a very broad term that describes solutions across a large variety of industries, including:

- *Electrical power grids and electrical generation plants
- *Environmental control systems
- *Traffic signals
- *Water management systems
- *Refining and chemical plants
- *Pharmaceutical manufacturing

SCADA:

SCADA is the acronym for Supervisory Control And Data Acquisition. SCADA may be called Human-Machine Interface (HMI) in Europe. The term refers to a large-scale, distributed measurement (and control) system. SCADA systems are used to monitor or to control chemical, physical or transport processes.

The three components of a SCADA system are:

1. Multiple Remote Terminal Units (also known as RTUs or Outstations).
2. Master Station and HMI Computer(s).
3. Communication infrastructure

Contents

- *1 Systems concepts
- *2 Human Machine Interface
- *3 Hardware solutions
- *4 System components
- *5 Remote Terminal Unit (RTU)
- *6 Master Station
- *7 Operational philosophy
- *8 Communication infrastructure and methods
- *9 Future trends in SCADA
- *10 Practical uses
- *11 External links

The term SCADA usually refers to a central system that monitors and controls a complete site. The bulk of the site control is actually performed automatically by a Remote Terminal Unit (RTU) or by a Programmable Logic Controller (PLC). Host control functions are almost always restricted to basic site override or supervisory level capability.

SCADA systems typically implement a distributed database which contains data elements called points. A point represents a single input or output value monitored or controlled by the system. Points can be either "hard" or "soft". A hard point is representative of an actual input or output connected to the system, while a soft point represents the result of logic and math operations applied to other hard and soft points. The point values are normally stored as value-timestamp combinations; the value and the timestamp when the value was recorded or calculated. A series of value-timestamp combinations is the history of that point.

DCS vs. SCADA DCS and SCADA are monitoring and control mechanisms that are used in industrial installations to keep track and control of the processes and equipment; to ensure that everything goes smoothly, and none of the equipment work outside the specified limits. The most significant difference between the two is their general design. DCS, or Data Control System, is process oriented, as it focuses more on the processes in each step of the operation. SCADA, or Supervisory Control and Data Acquisition, focuses more on the acquisition and collation of data for reference of the personnel who are charged with keeping track of the operation.

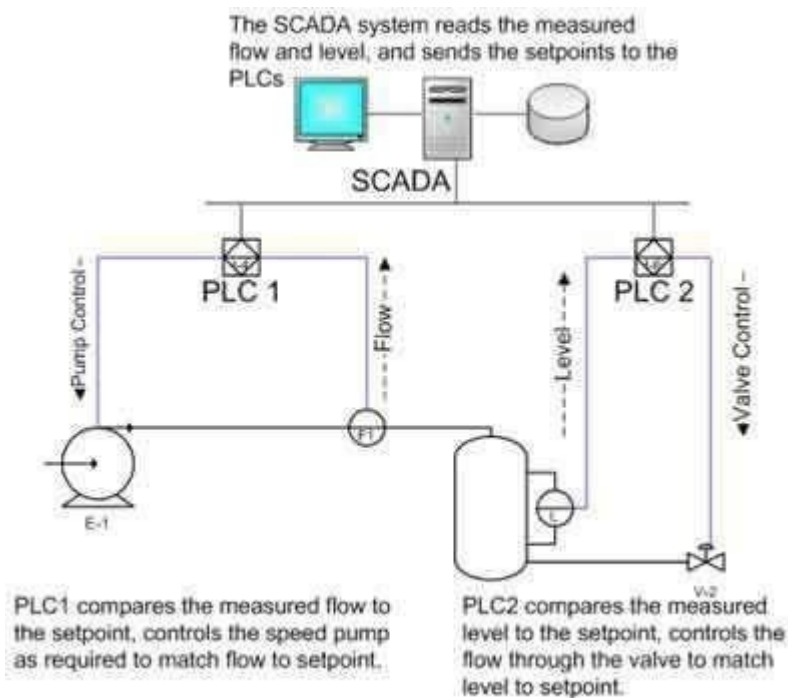

DCS is process state driven, while SCADA is event driven. DCS does all its tasks in a sequential manner, and events are not recorded until it is scanned by the station. In contrast, SCADA is event driven. It does not call scans on a regular basis, but waits for an event or for a change in value in one component to trigger certain actions. SCADA is a bit more advantageous in this aspect, as it lightens

the load of the host. Changes are also recorded much earlier, as an event is logged as soon as a value changes state. In terms of applications, DCS is the system of choice for installations that are limited to a small locale, like a single factory or plant, while SCADA is preferred when the entire system is spread across a much larger geographic location, examples of which would be oil wells spread out in a large field. Part of the reason for this is the fact that DCS needs to be always connected to the I/O of the system, while SCADA is expected to perform even when field communications fail for some time. SCADA does this by keeping a record of all current values, so that even if the base station is unable to extract new information from a remote location, it would still be able to present the last recorded values.

Summary: 1.DCS is process oriented, while SCADA is data acquisition oriented. 2.DCS is process state driven, while SCADA is event driven. 3.DCS is commonly used to handle operations on a single locale, while SCADA is preferred for applications that are spread over a wide geographic location.